

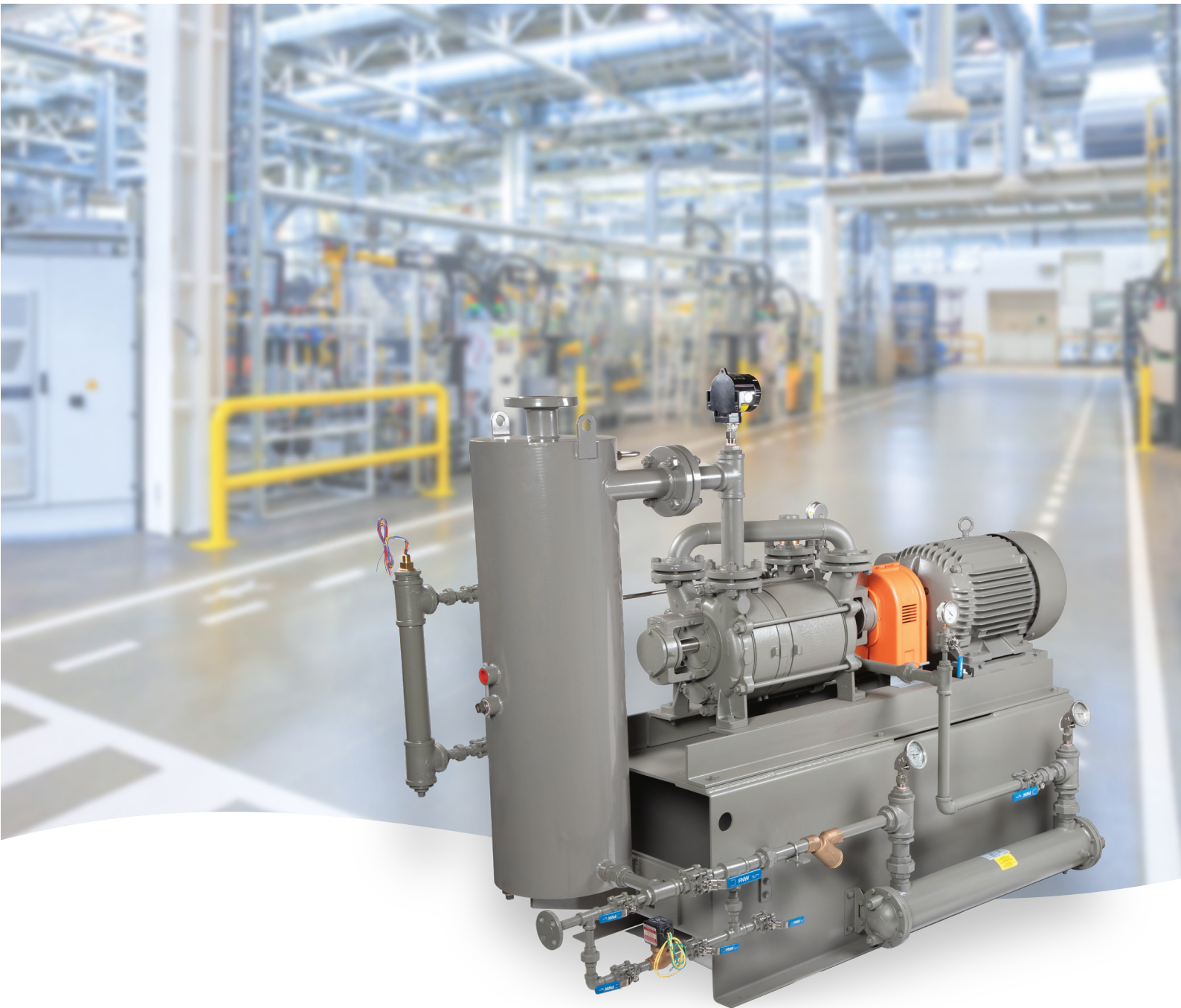

# SIHI® Pre-Engineered Liquid Ring Vacuum Systems

Base Mount | XBAR | TRS



*Experience In Motion*

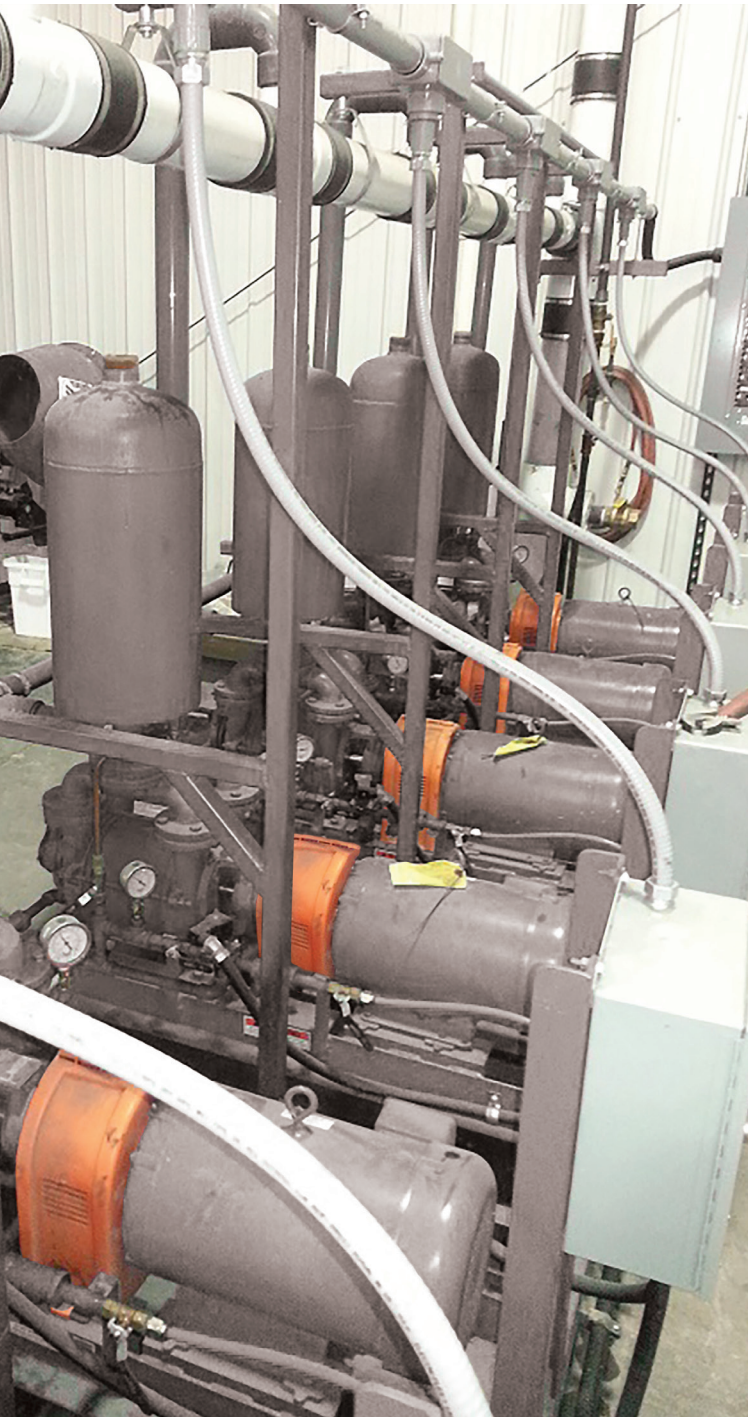

## Pre-engineered to add value

Whether you're running continuous or batch processes, Flowserve SIHI pre-engineered packages offer efficient, turnkey commissioning of complete liquid ring vacuum systems. Ranging from simple base-mounted pump and motor packages for use with your existing system to fully functional integrated systems for new or expanding installations, these optimized solutions enable you to get your process running quickly and economically.

### The right fit for your application

Flowserve offers three pre-engineered vacuum system packages to provide the right fit for your application and technical requirements.

- **Base Mount** — The simplest of the pre-engineered packages, the Base Mount system is designed to be integrated with existing equipment or a centralized recirculation seal fluid system.
- **XBAR** — Turnkey functionality and process flexibility are hallmarks of the XBAR system, which is available with once-through or partial recirculation service liquid arrangements. Recirculation rates range from 0 to 50%, depending on your processing conditions, and are easily modified with simple valve adjustments.
- **TRS** — The TRS system is designed specifically for applications requiring total recirculation of the service liquid. The TRS package is preferred for processes that need to conserve resources or utilize hazardous fluids that pose environmental concerns.



## Benefits of SIHI pre-engineered vacuum systems

### Proven system integration

Design expertise is critical in vacuum systems, where the slightest miscalculation can significantly reduce the capability of the system. With a SIHI package, you can rest assured that every component has been carefully engineered to complement each other, enabling your process to run at peak efficiency.

### Cost-effective turnkey solutions

SIHI vacuum packages reduce your costs by eliminating the need for engineering and simplifying installation. Each package comes ready for hookup to intake, discharge, electrical and service fluid connections. You'll also save on operating costs over time by using an efficient, fully integrated system.

### Compact, resource-conserving designs

SIHI vacuum systems are designed to minimize space requirements, conserving your valuable floor space. Partial recirculation (XBAR) or total recirculation (TRS) options can minimize your use of service liquid when necessary. TRS packages also enable the reduction of emissions and the recovery of valuable products.

### A single source of accountability

Save time and hassles, minimize confusion, and eliminate conflicts between vendors. SIHI vacuum systems from Flowserve provide you with a complete solution — with just one point of contact and one warranty.

## The Flowserve SIHI advantage

With a century of experience engineering liquid ring vacuum pumps and compressors for diverse industries and applications, Flowserve SIHI offers a higher level of system design, manufacturing and operation expertise.

- **Manufactured in North America** — SIHI is one of the few remaining brands of liquid ring vacuum pumps and compressors still manufactured in a North American, ISO 9001 facility. We also have application engineering, system design and aftermarket support teams based in North America.
- **Experienced and trusted supplier** — Flowserve SIHI has been an established supplier to North America's major industrial and process markets for more than six decades.
- **Designed to meet your needs** — From pre-engineered process pumps to special purpose designs, SIHI can construct vacuum pumps and systems in a wider range of materials than other manufacturers.
- **Quality control** — All SIHI vacuum pump models and pre-engineered systems undergo rigorous factory testing to ensure reliable, high-quality performance.
- **Local support from a knowledgeable partner** — Whether you're installing all-new equipment or upgrading existing systems, Flowserve SIHI offers you industry-leading experience and support.

## Choose the SIHI vacuum system that's right for you

### SIHI Base Mount systems

The Base Mount package provides you with the essential components needed to integrate a SIHI vacuum pump into your existing system. It includes a pump, motor, coupling, guard and baseplate.

The Base Mount package is well-suited for customers integrating the system to an existing infrastructure, or who wish to upgrade pumps in sites with existing piping systems.

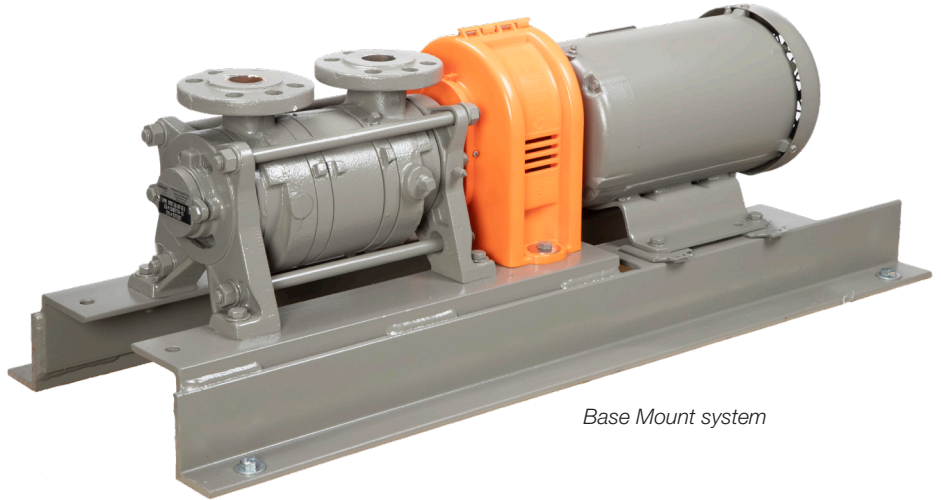

*Base Mount system*

### SIHI XBAR systems

The XBAR package provides you with a choice of service liquid discharge options. The service liquid piping arrangement is adjustable, providing an easy means to match it to system demands.

The XBAR system enables 0 to 50% recirculation of the service liquid supply. This design reduces water consumption and waste effluent remediation.

To provide this flexibility, the XBAR expands on the Base Mount system by adding auxiliary componentry that enables you to control service liquid flow rates.

The XBAR system is ideal for new installations requiring integrated, turnkey vacuum solutions backed by a single source. It is also an excellent choice for operations that wish to conserve costs and resources.



*XBAR system*



TRS system

## SIHI TRS systems

The TRS package is the most advanced of the SIHI pre-engineered vacuum systems. With recirculation levels up to 100%, it greatly reduces service liquid usage as well as discharge waste. The cleaner the application, the greater the possible reduction in service liquid.

Building on the foundation of the XBAR package, the TRS system utilizes a larger separator tank, level sensors, a heat exchanger and other auxiliary components to optimize service liquid recirculation.

The TRS vacuum system is ideal for processes where the service liquid is not environmentally acceptable for discharge or those utilizing service liquids other than water. Total service liquid containment provides environmental compliance where water effluent discharge has limitations or when the water supply is costly or in short supply. The cleaner the application, the greater reduction of fresh service liquid possible.

## Ideal for demanding industrial processes

SIHI pre-engineered vacuum systems are designed to handle the most demanding gas-handling applications. A broad selection of alloys is available for corrosive applications.

### Principle industries

- Chemical
- Petroleum
- Pharmaceutical
- Power
- Electronics
- Machinery manufacturing (OEM)
- Food and beverage
- Rubber and plastics

### Key vacuum applications

- Drying
- Distillation
- Filtration
- Sterilization
- Deaeration and gasification
- Forming and extrusion
- Vacuum chucking
- Scrubbing and vapor recovery
- Packaging and bottling
- Poultry processing
- Batch reactors

# Service liquid arrangements

## Once-through

The simplest arrangement with the lowest initial cost, once-through service liquid arrangements discharge 100% of the liquid from the pump system. They are used in processes where service liquid is plentiful and may be disposed of either through municipal drain or secondary remediation.

*The XBAR vacuum system is capable of once-through operation.*

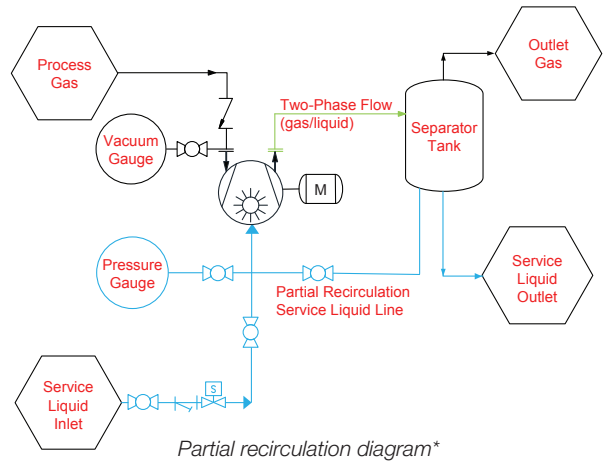

## Partial recirculation

For applications with minimal contamination, the ability to control service liquid flow rates allows you to accommodate changing service liquid temperatures and optimize the required operating vacuum level. Any degree of partial recirculation reduces service liquid consumption.

With this arrangement, a minimum of 50% of the required service liquid is discharged. The balance of flow is recirculated to the pump's service liquid intake. Fresh liquid is continually added to compensate for the volume discharged and provides cooling for the recirculated liquid. The reduction in water consumption results in significant water and sewer resources costs savings.

*The XBAR system is capable of partial recirculation operation.*

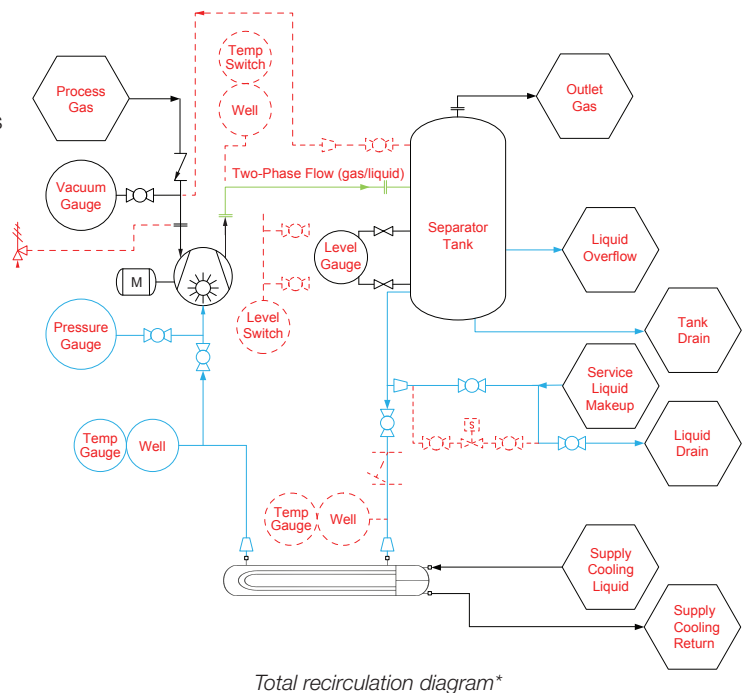

## Total recirculation

Systems with limited service water supply or that contain toxic process contaminants will benefit from a total recirculation arrangement. In this arrangement, up to 100% of the service liquid is routed back to the pump's service liquid intake. Little to no liquid is discharged. Service liquid may need to be periodically changed or purged with clean liquid to maintain performance. Contaminated service liquid should undergo remediation or be responsibly disposed.

*Total recirculation is only available on the TRS system.*

*\*Subject to change without notice.*

# Performance data

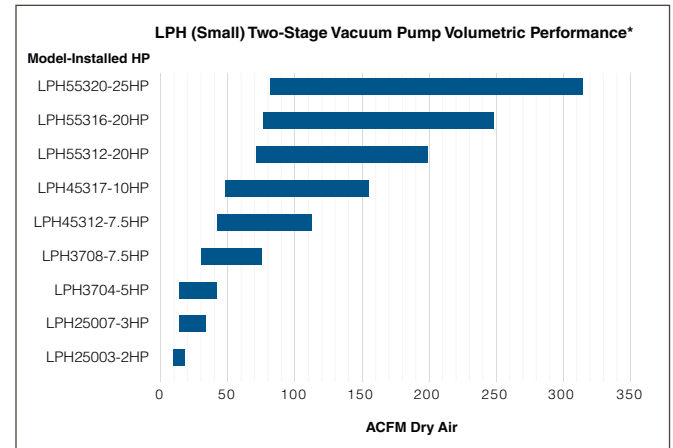
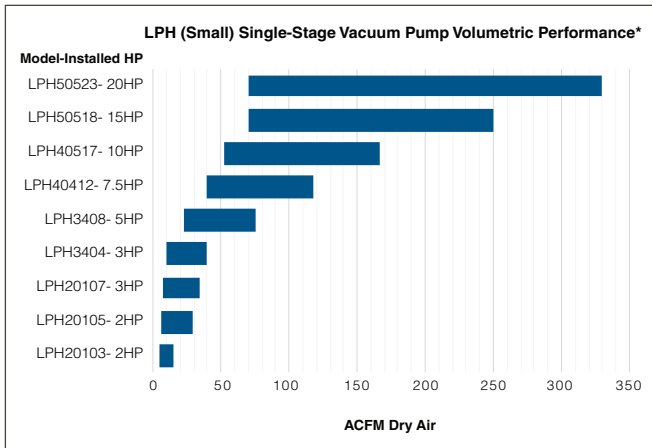
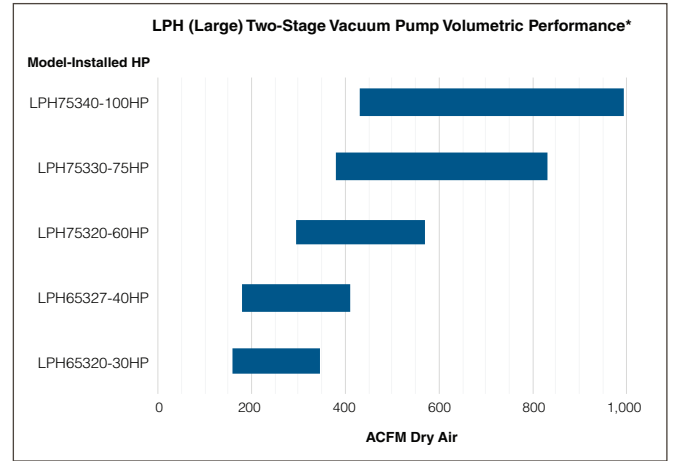
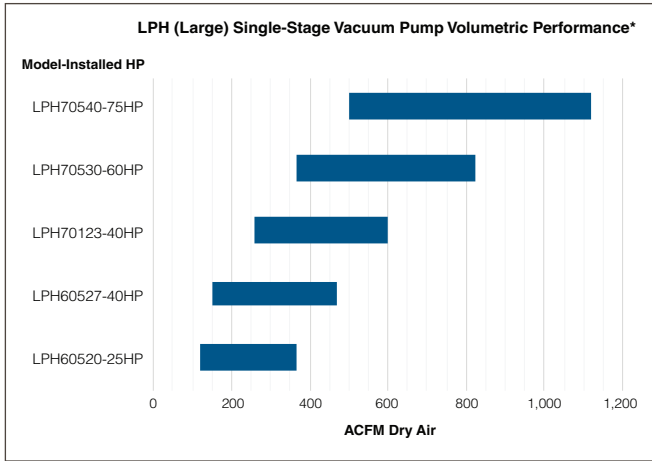

\* HP shown is the maximum installed motor HP based on standard running operating conditions at maximum speed. Performance based on 15°C (60°F) water as the service liquid.

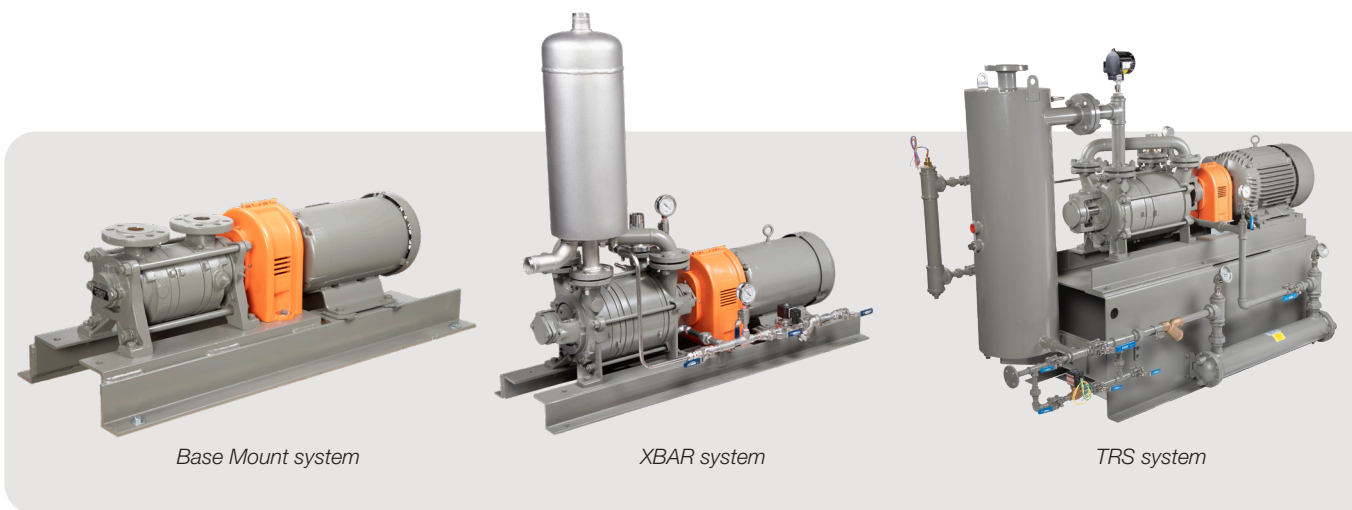



Flowserve Corporation  
5215 North O'Connor Blvd.  
Suite 2300  
Irving, Texas 75039-5421 USA  
Telephone: +1 937 890 5839

Flowserve Corporation has established industry leadership in the design and manufacture of its products. When properly selected, this Flowserve product is designed to perform its intended function safely during its useful life. However, the purchaser or user of Flowserve products should be aware that Flowserve products might be used in numerous applications under a wide variety of industrial service conditions. Although Flowserve can provide general guidelines, it cannot provide specific data and warnings for all possible applications. The purchaser/user must therefore assume the ultimate responsibility for the proper sizing and selection, installation, operation, and maintenance of Flowserve products. The purchaser/user should read and understand the Installation Instructions included with the product, and train its employees and contractors in the safe use of Flowserve products in connection with the specific application.

While the information and specifications contained in this literature are believed to be accurate, they are supplied for informative purposes only and should not be considered certified or as a guarantee of satisfactory results by reliance thereon. Nothing contained herein is to be construed as a warranty or guarantee, express or implied, regarding any matter with respect to this product. Because Flowserve is continually improving and upgrading its product design, the specifications, dimensions and information contained herein are subject to change without notice. Should any question arise concerning these provisions, the purchaser/user should contact Flowserve Corporation at any one of its worldwide operations or offices.

©2020 Flowserve Corporation. All rights reserved. This document contains registered and unregistered trademarks of Flowserve Corporation. Other company, product, or service names may be trademarks or service marks of their respective companies.

**PUBR000027 (EN/A4)** March 2020