

Valtek[®] Compressor Anti-Surge Valve

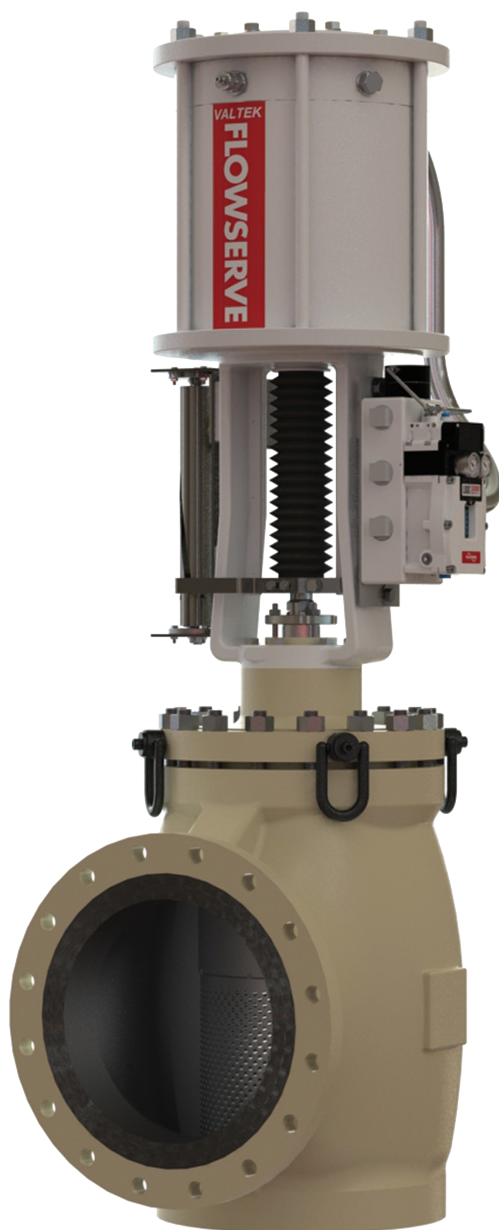

Fast, precise and reliable compressor surge control

The Valtek Compressor Anti-Surge Valve represents a revolutionary solution to anti-surge control by combining precise control and exceptional responsiveness in a simple, reliable package.

The Valtek Compressor Anti-Surge Valve delivers high-capacity, stable control when recycling, low-noise and low-vibration trims, and ease of maintenance — all designed specifically for use in the most challenging compressor anti-surge applications, including liquefied natural gas (LNG).

Flowserve engineered the compressor anti-surge solution to overcome the common challenges seen in compressor applications, where compressor surge can cause equipment failure and operational downtime. The Valtek Compressor Anti-Surge Valve protects the compressor from catastrophic surge damage by combining the abilities to provide rapid response, driving the valve open when needed, and steady-state positioning when recycling.

The Valtek Compressor Anti-Surge Valve is comprised of the following key components. They have been engineered to work together seamlessly to protect critical compressors from surging.

- Mark 100SC™ angle body valve
- Logix 3800JF™ positioner
- JetFlow™ relay
- MegaStream™ noise control
- Stealth™ noise control
- Linear piston actuators
- Actuator cushions
- SpiralTrack™ feedback

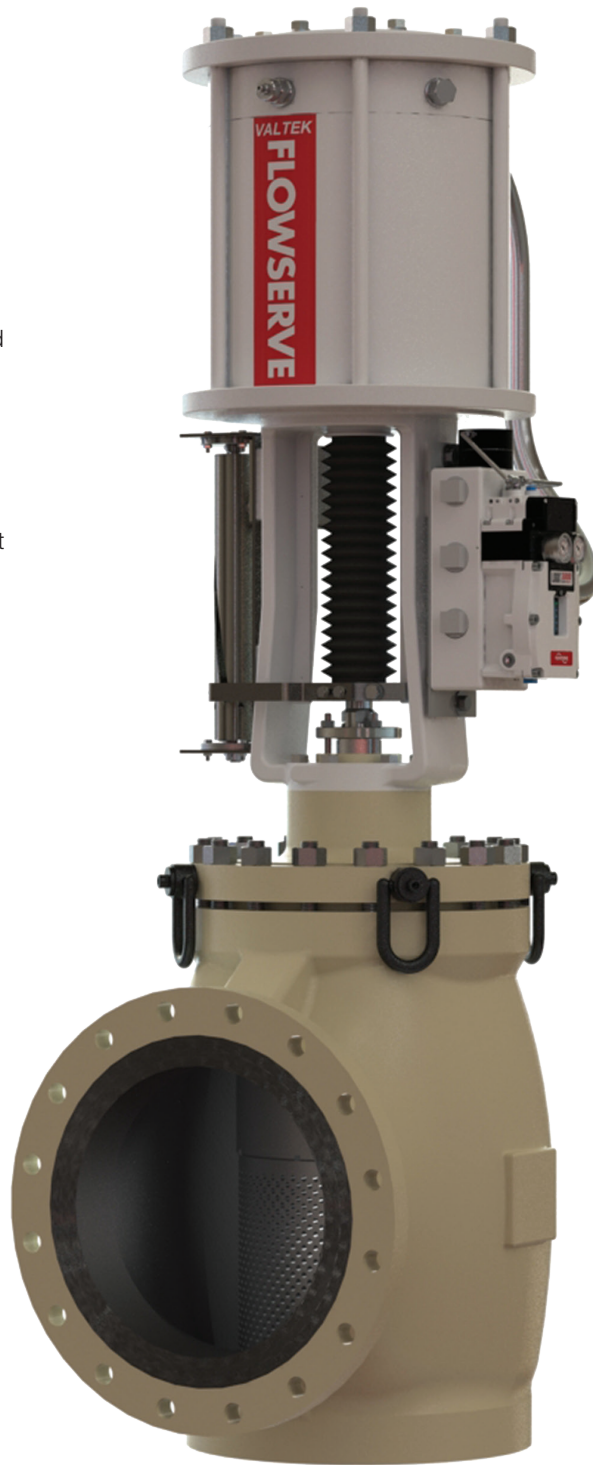

Figure 1: Valtek Compressor Anti-Surge Valve

Mark 100SC angle body valve

Exceptional capacity, noise and vibration control. The Valtek Compressor Anti-Surge Valve is designed for maximum capacity and noise control. Fluid velocity is managed by providing expanded outlets to match the fluid expansion as the pressure drops. Advanced trim designs attenuate noise and vibration, reducing system wear, damage and downtime.

The Mark 100SC valve body is a derivation of the highly successful Valtek Mark 100 valve line, which is also available if a globe-style valve is desired.

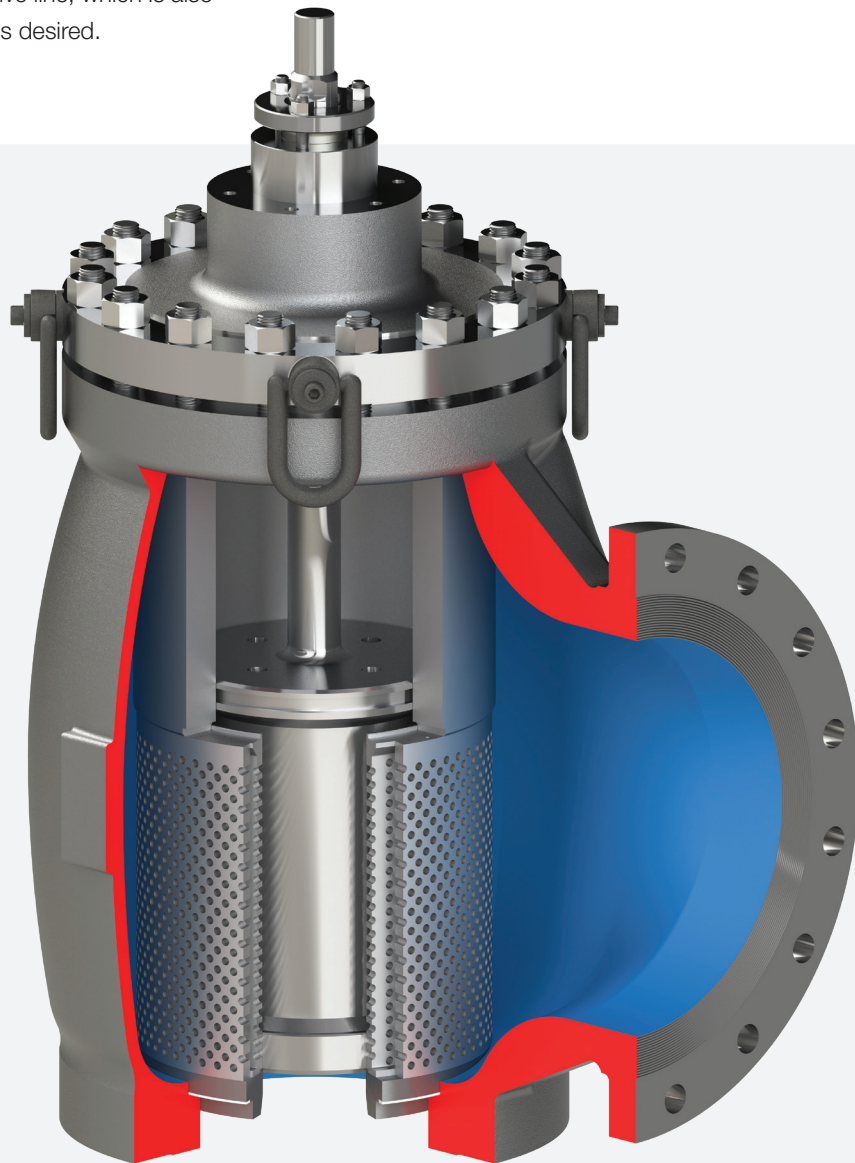
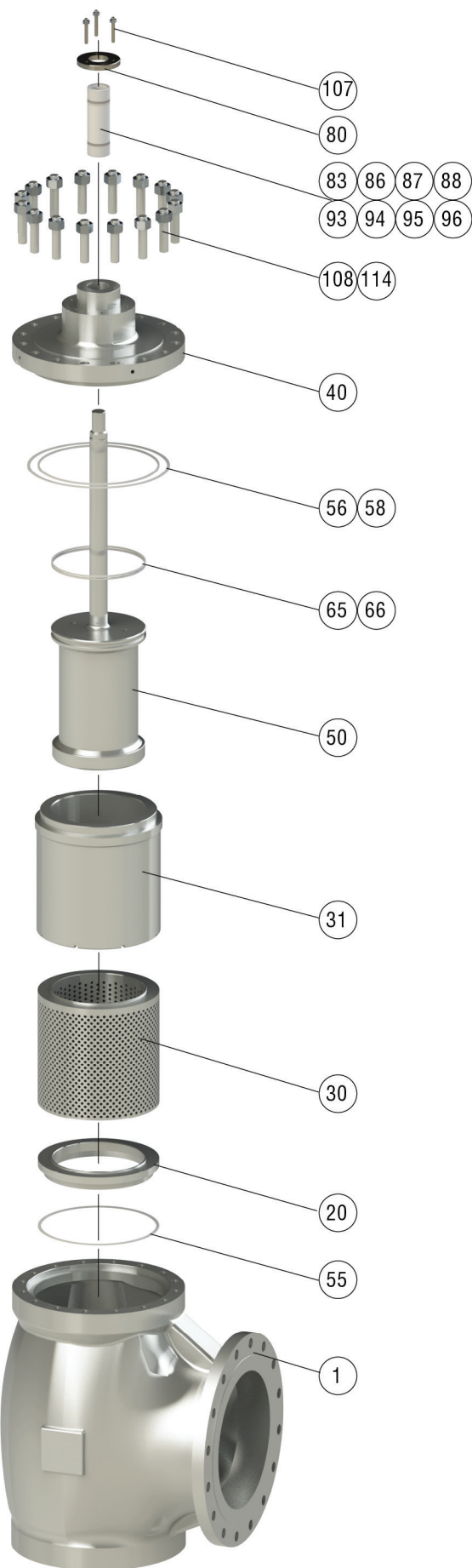

Figure 2: Mark 100SC angle body control valve

Exploded view: Mark 100SC
valve body assembly



Mark 100SC parts list and materials

Part	Item #	Qty.	Common Materials
Gland Flange Bolting	107	1 set	Carbon steels, stainless steels
Gland Flange	80	1	Carbon steels, stainless steels
Upper Guide Liner	86	1	PTFE, Grafoil®
Upper Guide Retainer	87	1	300 series stainless steel
Packing Set	88	1	PTFE, graphite
Packing Spacers	93 to 96	1 set	300 series stainless steel
Lower Guide	83	1	Bronze, Alloy 6
Body Bolting Stud, Nut	108, 114	1 set	B7-2H, B7M-2HM, B8-8
Bonnet	40	1	Carbon steels, stainless steels, chrome-moly alloys
Pressure-Balanced Sleeve Gasket	56	1	PTFE, spiral graphite
Bonnet Gasket	58	1	PTFE, spiral graphite
Pressure-Balanced Seals and Back-Up Rings	65, 66	1 set	O-ring with back-up rings, PTFE seals, carbon seals, metal seals
Plug	50	1	300 series stainless steel with Alloy 6 overlay, 400 series martensitic stainless steel
Pressure-Balanced Sleeve	31	1	300 series stainless steel with Alloy 6 overlay, 400 series martensitic stainless steel
Seat Retainer	30	1	300 series stainless steel, 400 series martensitic stainless steel
Seat Ring	20	1	300 series stainless steel with Alloy 6 overlay, 400 series martensitic stainless steel
Seat Gasket	55	1	PTFE, spiral graphite
Body	1	1	Carbon steels, stainless steels, chrome-moly alloys

® Grafoil is a registered trademark of Union Carbide Corporation.

Mark 100SC MegaStream maximum flow capacities and factors

Size Inlet x Outlet	Trim (in)		Stroke (in)	MegaStream Stages			
	Stage 1	Stage 2		1		2	
				C _v	x _T	C _v	x _T
8 x 8	7.75	7	5	981	0.67	593	0.75
8 x 10	7.75	7	8	1,660	0.67	942	0.75
8 x 12	7.75	7	8	1,910	0.67	968	0.75
10 x 10	9.75	9	6	1,480	0.67	899	0.75
10 x 16	9.75	9	10	3,050	0.67	1,530	0.75
10 x 18	9.75	9	10	3,380	0.67	1,550	0.75
10 x 20	9.75	9	10	3,740	0.67	1,570	0.75
12 x 12	11.25	10	8	2,120	0.67	1,320	0.75
12 x 16	11.25	10	12	3,450	0.67	2,000	0.75
12 x 18	11.25	10	12	3,800	0.67	2,050	0.75
12 x 20	11.25	10	12	4,160	0.67	2,080	0.75
12 x 24	11.25	10	12	4,900	0.67	2,120	0.75
16 x 16	15	13.5	8	3,100	0.67	1,830	0.75
16 x 20	15	13.5	12	5,070	0.67	2,760	0.75
16 x 24	15	13.5	16	7,470	0.67	3,720	0.75
16 x 30	15	13.5	16	9,200	0.67	3,810	0.75
20 x 20	18.5	16	12	5,390	0.67	3,240	0.75
20 x 24	18.5	16	16	7,730	0.67	4,370	0.75
20 x 30	18.5	16	20	11,100	0.67	5,590	0.75
20 x 36	18.5	16	20	13,100	0.67	5,730	0.75
24 x 24	24	21.5	12	7,850	0.67	4,440	0.75
24 x 30	24	21.5	16	11,700	0.67	6,000	0.75
24 x 36	24	21.5	20	16,400	0.67	7,580	0.75
30 x 30	28	24	18	12,100	0.67	7,280	0.75
30 x 36	28	24	24	17,400	0.67	9,830	0.75

Mark 100SC body dimensions

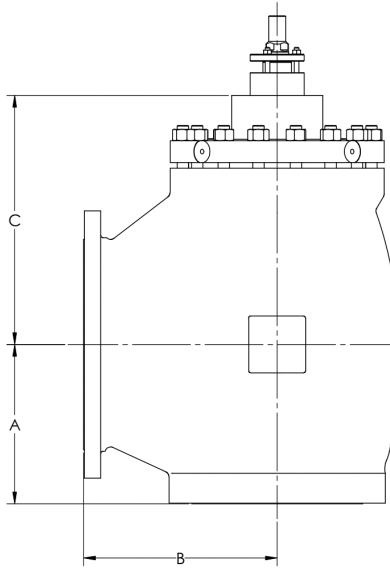

Size Inlet x Outlet	Class 150					Class 300					Class 600				
	A	B	C	Weight*		A	B	C	Weight*		A	B	C	Weight*	
				lb	kg				lb	kg				lb	kg
8x8	10.69	7.50	12.37	429	195	11.19	8.00	12.00	575	261	13.50	8.50	12.87	800	363
8x10	13.25	10.50	15.37	554	251	13.94	10.50	15.50	741	336	14.81	10.50	15.93	1,017	461
8x12	14.50	10.50	15.37	605	274	15.25	11.00	14.99	821	372	16.12	11.50	14.93	1,116	506
10x10	13.25	8.50	14.14	645	293	13.94	9.00	13.89	854	387	16.00	10.50	13.89	1,262	572
10x16	13.25	12.50	18.02	895	406	15.00	13.50	17.33	1,238	562	19.00	14.00	17.20	1,817	824
10x18	13.25	13.00	18.95	963	437	16.00	15.00	18.07	1,428	648	20.00	15.50	18.51	2,121	962
10x20	15.00	14.50	19.74	1,134	514	17.00	16.00	19.16	1,628	738	20.00	17.00	19.63	2,500	1,134
12x12	14.50	10.50	16.89	1,031	468	15.25	11.00	16.89	1,337	606	17.50	11.50	16.39	1,799	816
12x16	17.00	14.00	21.89	1,379	626	17.75	15.25	21.14	1,800	816	19.25	15.00	21.39	2,427	1,101
12x18	17.00	15.00	20.89	1,398	634	19.75	15.50	20.89	1,942	881	21.00	15.50	20.89	2,626	1,191
12x20	17.00	15.00	20.89	1,489	675	19.75	16.00	20.39	2,122	963	21.00	16.50	19.89	2,913	1,321
12x24	19.00	17.00	23.14	1,808	820	19.75	19.00	21.52	2,602	1,180	22.00	19.50	22.64	3,761	1,706
16x16	17.00	13.00	19.45	1,718	779	20.81	14.00	19.95	2,374	1,077	21.81	14.50	20.01	3,278	1,487
16x20	20.00	15.00	22.45	2,061	935	20.81	16.00	21.45	2,734	1,240	21.81	16.50	21.51	3,747	1,700
16x24	20.00	19.00	26.45	2,551	1,157	20.81	19.00	26.45	3,527	1,600	23.00	20.00	26.01	4,939	2,240
16x30	20.00	21.00	25.45	2,981	1,352	23.00	23.00	27.45	4,566	2,071	24.00	23.00	27.63	6,341	2,876
20x20	20.68	16.00	24.18	3,077	1,396	21.38	17.00	23.31	3,960	1,796	25.00	17.00	23.49	5,451	2,473
20x24	23.00	20.00	28.18	3,701	1,679	23.63	20.00	28.31	4,866	2,207	25.25	20.00	28.74	6,607	2,997
20x30	25.00	23.00	33.18	4,790	2,173	25.00	23.00	33.31	6,314	2,864	32.00	24.00	32.74	9,135	4,144
20x36	25.00	24.00	32.18	5,217	2,366	26.00	26.00	32.70	7,253	3,290	34.00	27.50	33.24	11,491	5,212
24x24	25.00	16.50	27.50	5,238	2,376	27.00	18.50	29.25	7,547	3,423	30.00	19.00	30.37	10,543	4,782
24x30	27.38	21.00	31.00	6,460	2,930	28.22	23.00	33.74	9,199	4,173	30.31	23.50	33.87	12,446	5,645
24x36	31.12	24.00	36.00	7,900	3,583	33.62	27.00	36.74	11,121	5,044	36.31	28.00	37.37	15,763	7,150
30x30	31.12	23.00	33.21	8,577	3,890	33.62	23.00	33.69	11,211	5,085	34.00	24.00	33.56	15,509	7,035
30x36	31.12	28.00	40.19	10,753	4,877	33.62	28.00	40.69	13,927	6,317	36.31	28.00	41.56	19,361	8,782

* Weights are approximate and will change with different trim selections. Weights are body sub-assembly only and do not include actuators or accessories.

A: Centerline to inlet face

B: Centerline to outlet face

C: Outlet centerline to actuator match line

Trim options

Mark 100SC Stealth trim

Stealth valve trim is the most sophisticated noise attenuation design available. It effectively attenuates noise and vibration in the most demanding high-pressure drop applications.

Stealth is produced by laser-cutting circular discs, forming fluid passageways. Discs are stacked and braised together, forming a complete seat retainer. Gradual pressure reduction across each stage reduces high velocities that generate noise and vibration. Small passages leverage frequency shifting, which also lower noise and vibration. Patented WaveCracker effects are employed to randomize noise, reducing noise even further. Finally, angled outlet paths direct the flow to the valve exit to reduce exit turbulence, thereby lowering noise and increasing the flow capacity of the valve.

For more details on the design and functionality of Stealth valve trim, please refer to Flowserve Gaseous Noise Control, publication FCD FCENBR0067.

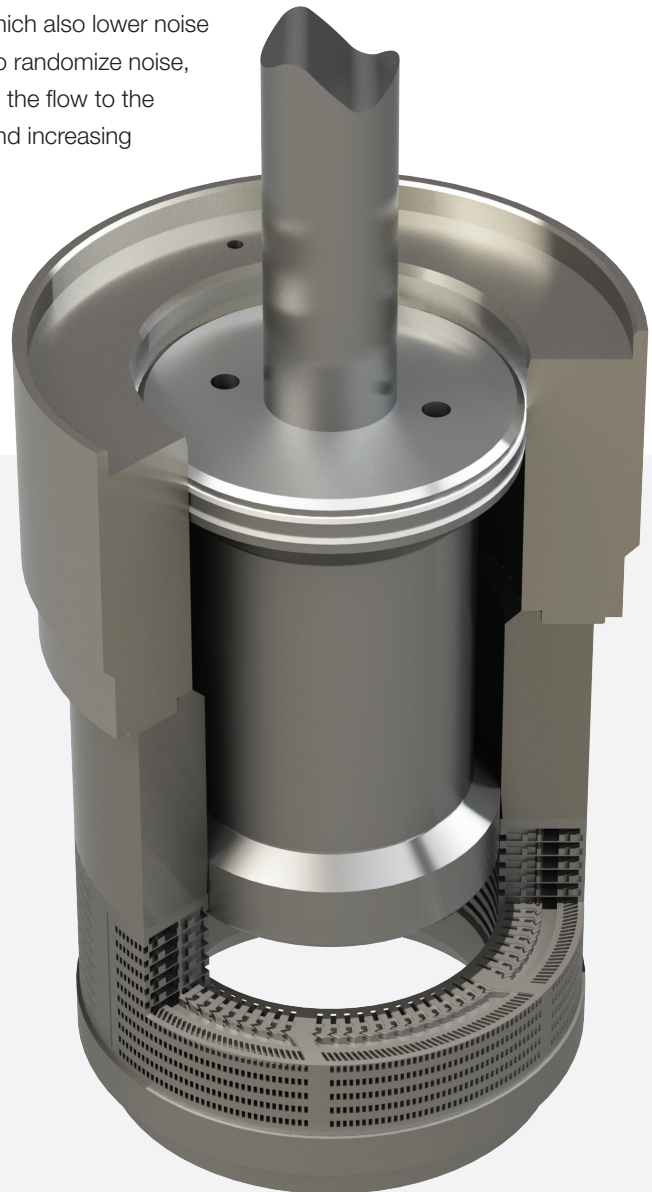

Figure 3: Mark 100SC Stealth trim

Mark 100SC MegaStream trim

MegaStream valve trim effectively attenuates noise and vibration in control valves by employing a heavy-duty, drilled-hole seat retainer (cage) with up to seven stages of pressure reduction. Decades of proven service make this cage one of the most common and effective solutions to control valve noise.

Pressure drops are distributed across retainer stages. Each stage is designed to take a smaller pressure drop, avoiding the high velocities present in single throttling-point trims. Fluid expansion and velocity are controlled by increasing the flow areas of each subsequent stage.

For more details on the design and functionality of MegaStream valve trim, please refer to Flowserve Gaseous Noise Control, publication FCD FCENBR0067.



Figure 4: Mark 100SC MegaStream trim

Available actuators

Mark 100SC inlet port size

Valve Size	Rating Class
6	150/600
8	150/600
10	150/600
12	150/600
14	150/600
16	150/600
18	150/600
20	150/600
24	150/600
30	150/600

VL-ES and VL-NS actuators

100	150	200	300	400
Std.	Opt.	Opt.	-	-
Std.	Opt.	Opt.	-	-
Std.	Opt.	Opt.	-	-
Std.	Opt.	Opt.	Opt.	Opt.
Std.	Opt.	Opt.	Opt.	Opt.
Opt.	Opt.	Std.	Opt.	Opt.
Opt.	Opt.	Std.	Opt.	Opt.
Opt.	Opt.	Std.	Opt.	Opt.
-	-	Opt.	Std.	Opt.
-	-	Opt.	Std.	Opt.

VL-Cushion actuator design

Compressor anti-surge applications often require fast stroke speeds and long stroke lengths. Fast stroke speeds and long stroke lengths can create a risk of impact damage. The simple, durable VL-Cushion design restricts the flow of air coming out the actuator just before the actuator hits the end stop, providing a pneumatic cushion that protects valves and connected systems from impact damage. Flow of air out the actuator is adjustable to provide a softer or harder cushion.

Because the VL-Cushion slows down the stroke speed as it approaches the end stops, consideration must be given to required stroke speeds. Typical stroke speeds should be timed from when the actuator begins to move until the actuator engages the cushion. Time while the cushion is engaged should not be included in the stroke speed.

An air cushion may be considered when the actuator is 2,540 mm² (100 in²) or larger. Smaller actuators do not typically require cushioning.

A simple equation can be used to evaluate the potential for impact damage. *Refer to equation on page 13.*

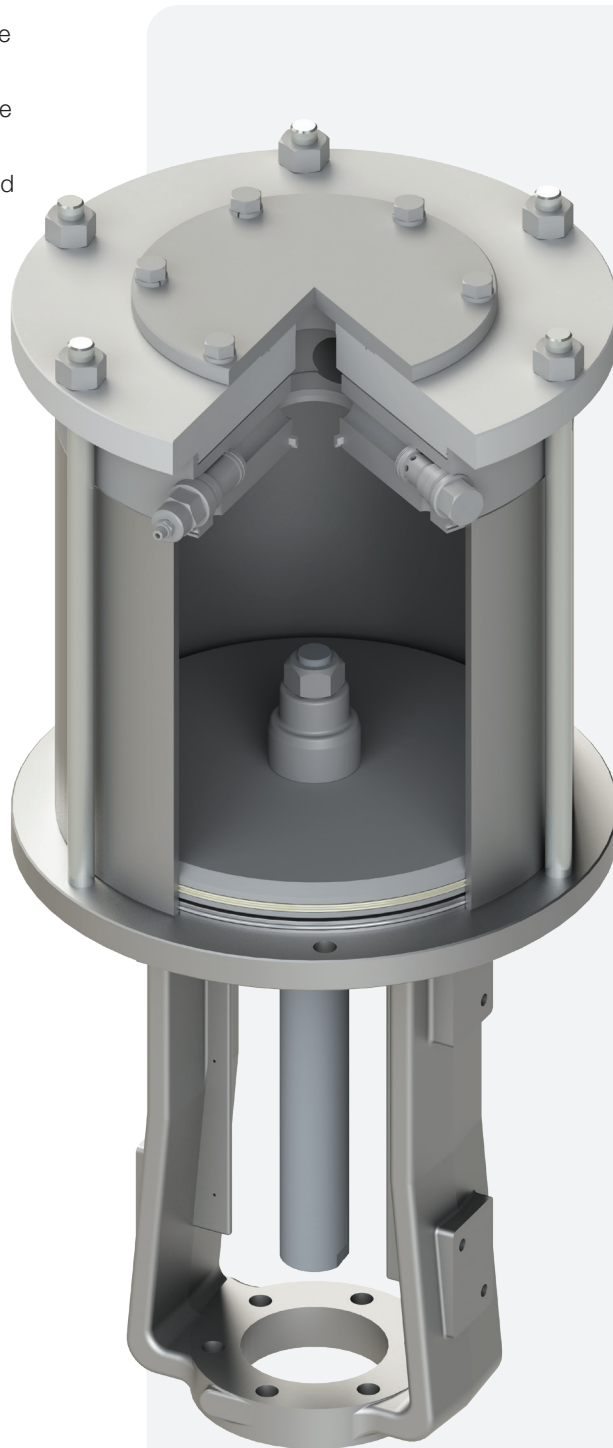
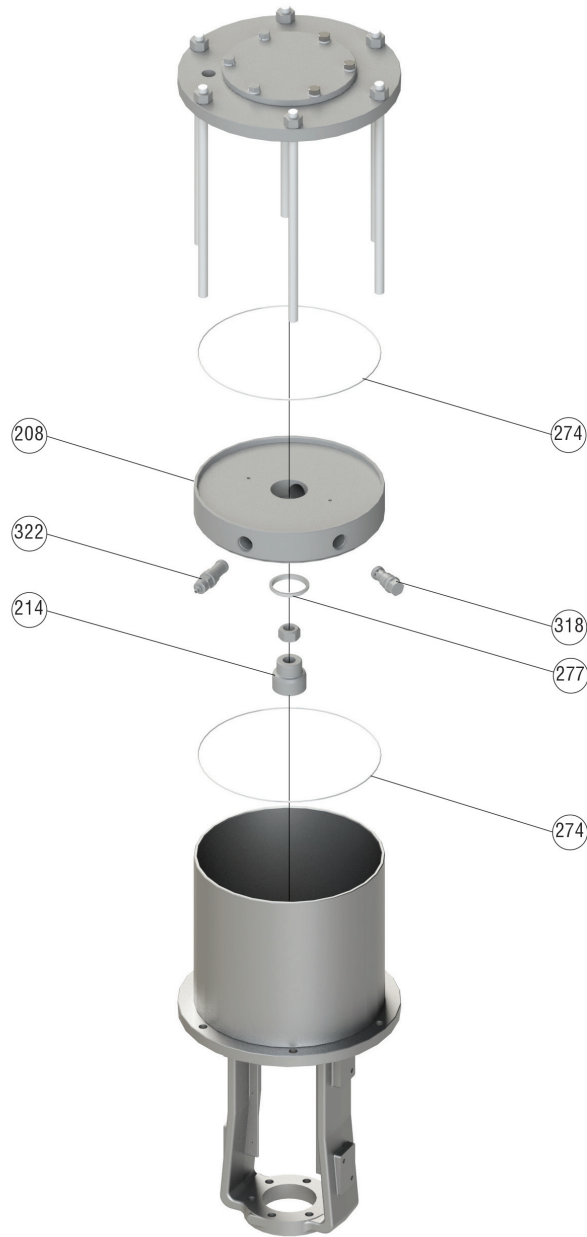

Figure 5: VL-Cushion design

Exploded view: VL-Cushion



Part*	Item #	Qty.	Common Materials
Manifold	208	1	Carbon steel
Spear	214	1	416 stainless steel
O-Ring	274	1	Buna-N
Wiper Seal	277	1	Molythane
Check Valve	318	1	Steel, Buna-N
Speed Control Valve	322	1	Steel, Buna-N

* Numbered items are part of the VL-Cushion. Items not numbered are parts of the base actuator.

This simple equation is provided to help determine if a cushion should be considered:

$$V_i = 3 \frac{\text{Stroke}}{\text{Times}}$$

V_i = Velocity at impact, in/s

Stroke = Valve stroke length, in

Times = The shorter of required or actual stroke times

When $V_i > 24$, a cushion should be considered. When $V_i > 36$, a cushion is strongly recommended.

The above equation will provide a guideline to valves that require a more detailed engineering review.

Other factors, such as the mass of the plug and drive train, should be evaluated for each valve application when there is possible risk of impact damage.

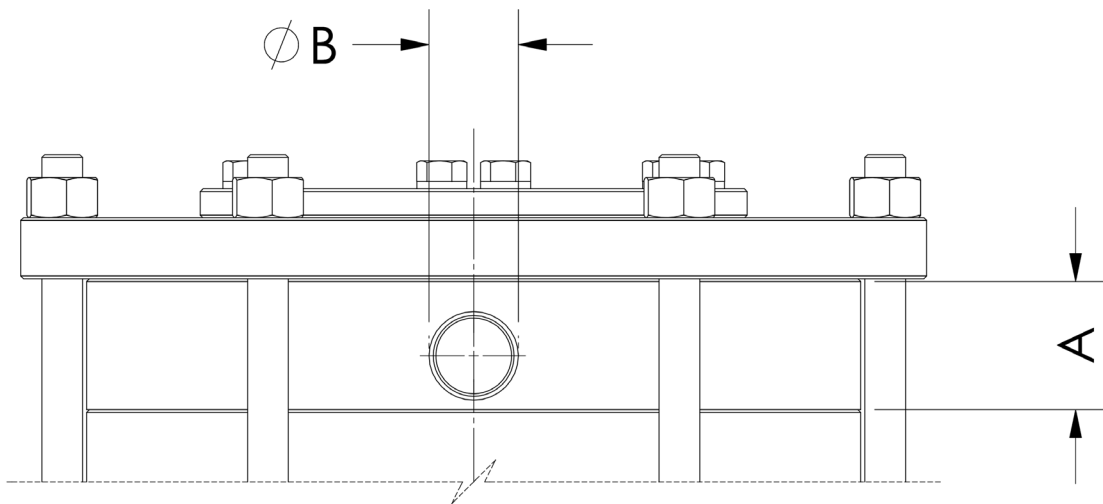

Port Size B	Cushion Thickness A
1.50	2.81
2.00	3.31

SpiralTrack

SpiralTrack's compact design provides precise, reliable electro-mechanical feedback to the positioner that features low backlash and is vibration-insensitive.

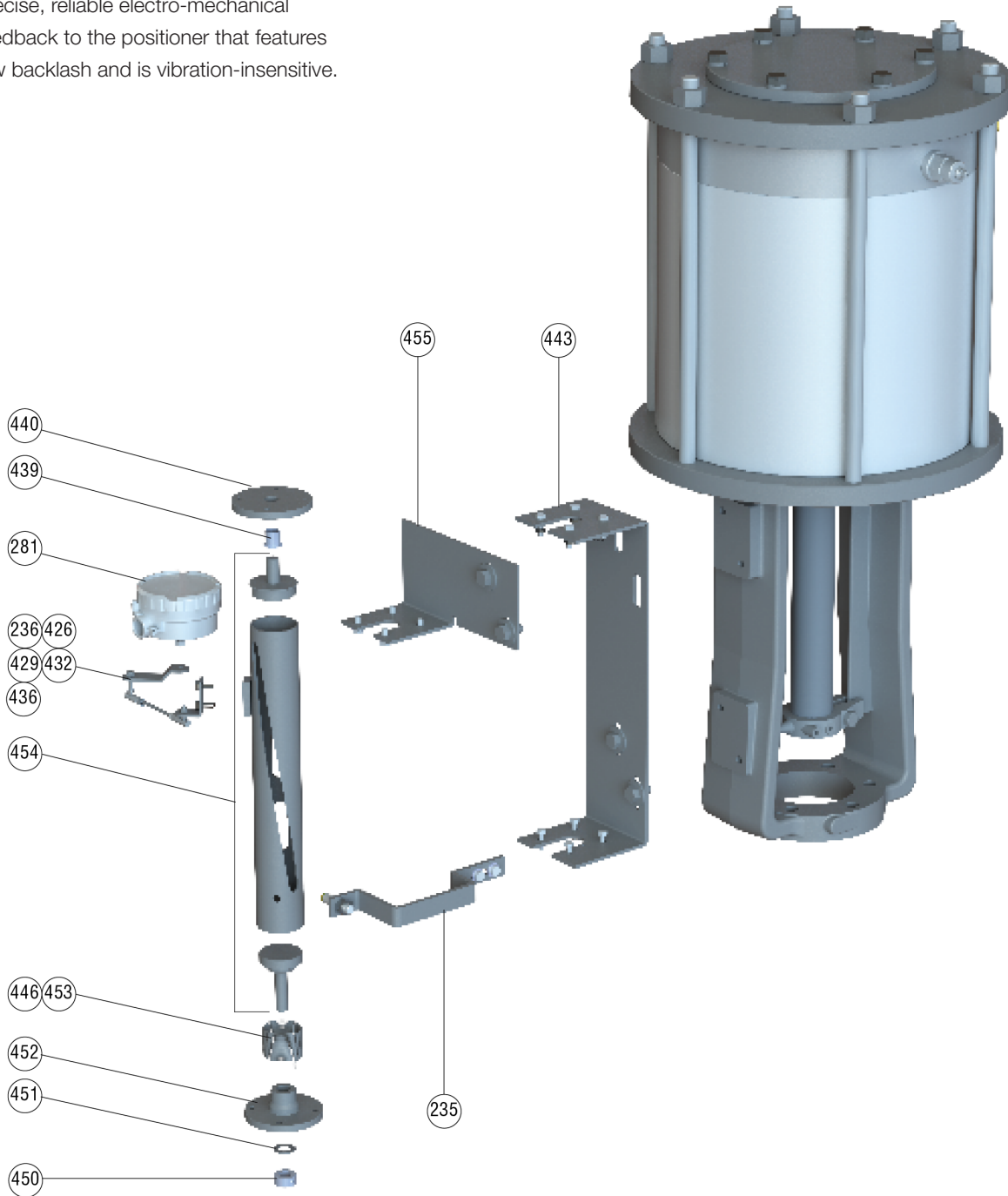

Part	Item #	Qty.	Common Materials
Remote Mounted Module	281	1	Aluminum
Bolt, Hex Head	404	4	Steel
Washer, Flat	438	4	Steel
Follower Arm Remote Mount	236	1	Stainless steel
Ball Joint, Swivel, RH	426	1	Carbon steel
Nut	427	1	Steel
Linkage Tie Rod	429	1	Carbon steel
Follower Pin Assembly	237	1	Steel
Locknut	431	1	Steel
Arm, Linkage	432	1	Stainless steel
Bolt, Hex Head	433	2	Steel
Washer, Flat	434	1	Steel
Locknut	435	2	Steel
Ball Joint, Swivel, LH	436	1	Carbon steel
Nut	437	1	Steel
Bearing, Sleeved, Flanged	439	2	Plastic
Housing, Bearing, Top	440	1	Aluminum
Bolt, Hex Head	441	8	Steel
Locknut	442	8	Steel
Bracket, Remote Mount	455	1	Steel
Assy., Tube, SpiralTrack	454	1	Stainless steel
Spring, Torsion, LH	453	1	Stainless steel
Spring, Torsion, RH	446	1	Stainless steel
Housing, Bearing, Bottom	452	1	Aluminum
Bearing, Thrust	451	1	Plastic
Shaft Collar	450	1	Stainless steel
Bracket, SpiralTrack	443	1	Steel
Bolt, Hex Head	444	4	Steel
Washer, Flat	445	4	Steel
Bolt, Hex Head	404	2	Steel
Washer, Flat	428	2	Steel
Take-Off Arm	235	1	Stainless steel

Logix 3800JF positioner

The Logix 3800JF positioner creates the ability to control with precision while also delivering high speed that anti-surge systems require. This unique positioner eliminates the need for volume boosters and switching valves. The Logix 3800JF positioner is an extension of the Logix 3800 positioner platform. It provides a simple user interface with a localized menu structure and quick calibration functions that make setup and tuning easy. The advanced diagnostic capabilities of the Logix 3800JF positioner allow users to quickly check the status and health of both the positioner and the valve.

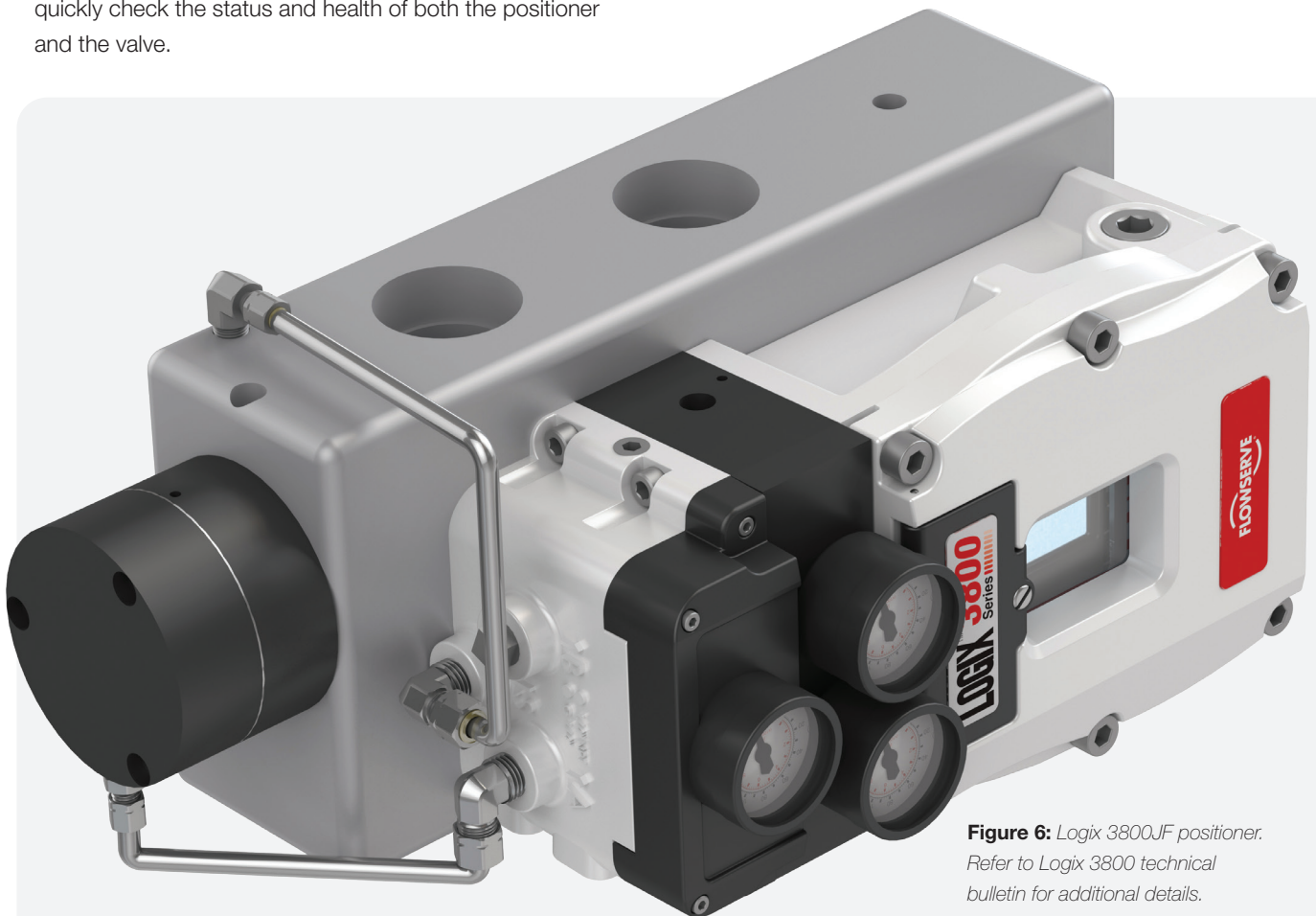

Figure 6: Logix 3800JF positioner. Refer to Logix 3800 technical bulletin for additional details.

Logix 3800JF positioner specifications and certifications

Performance Characteristics*	Description
Resolution	≤0.25%
Linearity	±1.25%
Repeatability	≤0.25%
Hysteresis	≤1.00%
Deadband	≤0.30%
Sensitivity	≤0.25%
Stability	≤0.40%
Long-Term Drift	≤0.50%
Supply Pressure Effect	≤0.20% per 10 psi (0.69 bar)

*Parameters characterized on a 1,290 cm² (200 in²) linear actuator

Temperature Range	Operating: -40°C to 85°C (-40°F to 185°F)
JetFlow Deadtime	300 ms (50 to 60% step)
JetFlow Frequency of Response	0.1 to 0.3 Hz
JetFlow Minimum Signal Response	0.20%

Safety Certifications	<ul style="list-style-type: none"> • ATEX/IECEX, Ex db, Ex tb, FM/US/Canada Ex Proof Class I Div 1 Gp B-D (A)Ex db • Dust Ignition Proof Class II, III Gp E-G (A)Ex tb , Type 4x, IP665 • SIL 3 capable
Communications Certification	<ul style="list-style-type: none"> • HART

JetFlow relay capacity curve

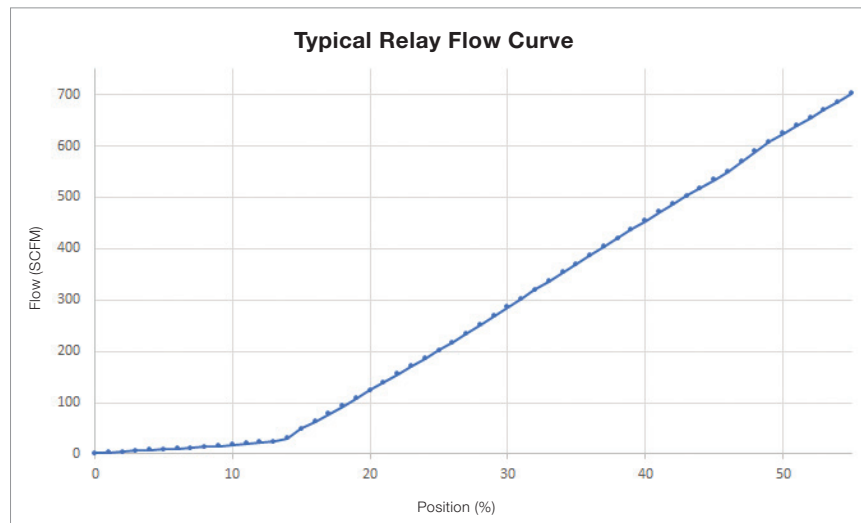

Logix 3800JF maximum flow capacity and steady-state air consumption

Relay Series	Port Size	Maximum Flow Capacity		Steady-State Air Consumption	
	NPT	C _v	SCFM @ 60 psi	C _v	SCFM @60 psi
J0	0.75	9	300	0.020	0.75
J1	1	9	300	0.020	0.75
J2	1.5	21	700	0.027	1.0
J3	2	50	1,800	0.054	2.0

JetFlow relay

The pneumatic JetFlow relay provides high flow rates and fast stroke speeds. It delivers proportional pneumatic output for both precision control for small step changes, and high flow when fast speeds are required. Additionally, the JetFlow relay contains only two moving parts, which reduces complexity and eliminates the need for volume boosters.

The JetFlow relay is SIL 3 capable. For other certifications, refer to the Logix 3800 certifications.

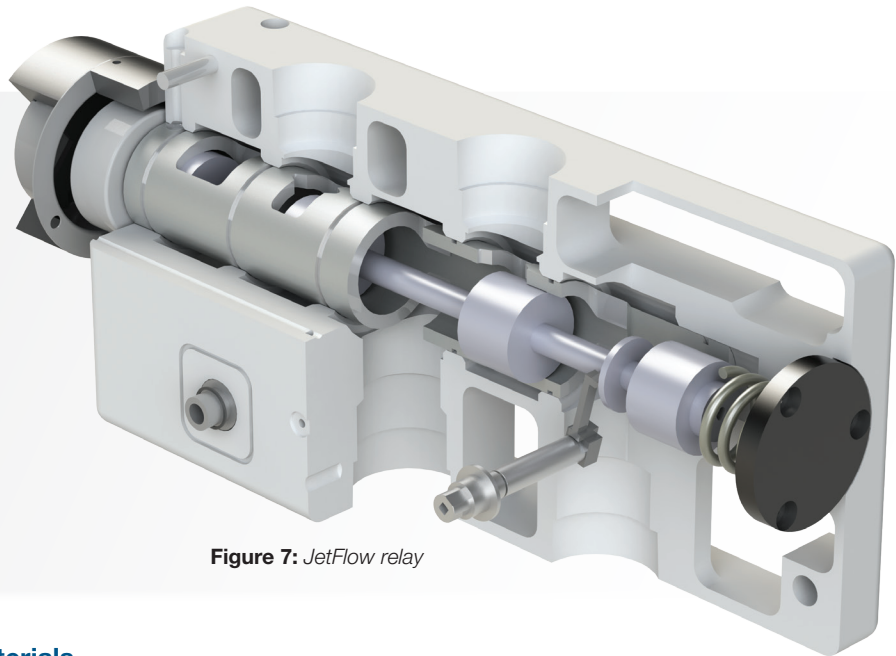
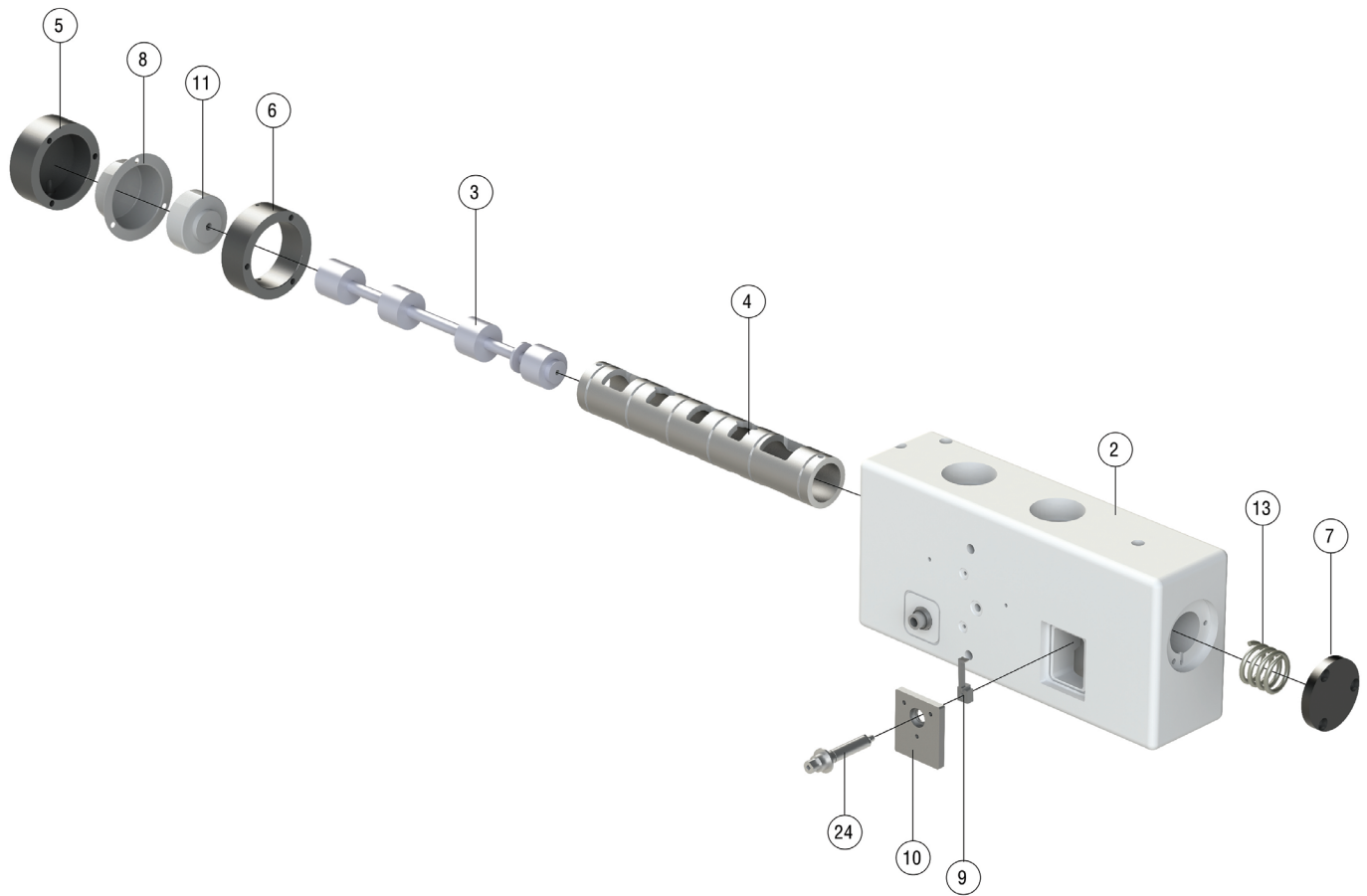

Figure 7: JetFlow relay

JetFlow relay parts list and materials

Part	Item #	Qty.	Common Materials
Spool	3	1	304 stainless steel
Sleeve	4	1	304 stainless steel
Diaphragm End Cap	5	1	Aluminum
Diaphragm Spacer	6	1	Aluminum
Spring Cap	7	1	Aluminum
Diaphragm	8	1	Buna-N rubber
Feedback Arm	9	1	Stainless steel
Feedback Cover	10	1	Stainless steel
Block	2	1	Aluminum
Piston Head	11	1	Aluminum
Manifold Insert	12	1	Aluminum
Spring	13	1	Stainless steel
Screw, Spring Cap	14	3	Stainless steel
Screw, Diaphragm	15	3	Stainless steel
Screw, Pressure Sensor Insert	16	2	Stainless steel

Exploded view: JetFlow relay



JetFlow relay parts list and materials – Continued

Part	Item #	Qty.	Common Materials
Screw, Feedback Cover	17	3	Stainless steel
Gasket, Feedback Cover	18	1	Buna-N Rubber
Screw, Manifold to Housing	19	4	Stainless steel
O-ring, Sleeve	20	6	Buna-N rubber
Bushing, Piston	21	1	Teflon®-infused PEEK®
Bushing, Piston	22	1	Teflon-infused PEEK
Feedback Bushing Retainer	23	1	Stainless steel
Feedback, DD, Namur Spring	24	1	Stainless steel
O-ring, Under Manifold	25	1	Buna-N rubber
O-ring, Under Manifold	26	2	Buna-N rubber
O-ring, Manifold	27	5	Buna-N rubber
Screw, Piston Head	28	1	Stainless steel
Screw, Spool Bushing Retainer	29	1	Stainless steel
Screw, Sleeve Retainer	30	2	Stainless steel

© Teflon is a registered trademark of the DuPont Company.

© PEEK is a registered trademark of Victrex plc Corp.



Flowserve Corporation
5215 North O'Connor Blvd.
Suite 700
Irving, Texas 75039-5421 USA
Telephone: +1 937 890 5839

VATB000191-03 (EN/AQ) September 2021

Flowserve Corporation has established industry leadership in the design and manufacture of its products. When properly selected, this Flowserve product is designed to perform its intended function safely during its useful life. However, the purchaser or user of Flowserve products should be aware that Flowserve products might be used in numerous applications under a wide variety of industrial service conditions. Although Flowserve can provide general guidelines, it cannot provide specific data and warnings for all possible applications. The purchaser/user must therefore assume the ultimate responsibility for the proper sizing and selection, installation, operation, and maintenance of Flowserve products. The purchaser/user should read and understand the Installation Instructions included with the product, and train its employees and contractors in the safe use of Flowserve products in connection with the specific application.

While the information and specifications contained in this literature are believed to be accurate, they are supplied for informative purposes only and should not be considered certified or as a guarantee of satisfactory results by reliance thereon. Nothing contained herein is to be construed as a warranty or guarantee, express or implied, regarding any matter with respect to this product. Because Flowserve is continually improving and upgrading its product design, the specifications, dimensions and information contained herein are subject to change without notice. Should any question arise concerning these provisions, the purchaser/user should contact Flowserve Corporation at any one of its worldwide operations or offices.

©2021 Flowserve Corporation. All rights reserved. This document contains registered and unregistered trademarks of Flowserve Corporation. Other company, product, or service names may be trademarks or service marks of their respective companies.