



Valtek[®] Compressor Anti-Surge Valve

Fast, precise and reliable compressor surge control



Experience In Motion

Responsive, precise and reliable anti-surge control

A revolutionary solution

The Valtek Compressor Anti-Surge Valve represents a revolutionary solution to anti-surge control by combining precise control and exceptional responsiveness in a simple, reliable package.

The Valtek Compressor Anti-Surge Valve delivers high-capacity, stable control when recycling, low-noise and low-vibration trims, and ease of maintenance — all designed specifically for use in the most challenging compressor anti-surge applications, including natural gas (LNG) liquefaction.

Flowserve engineered the compressor anti-surge solution to overcome the common challenges seen in compressor applications, where compressor surge can cause equipment failure and operational downtime. The Valtek Compressor Anti-Surge Valve solution protects the compressor from catastrophic surge damage by combining the abilities to provide rapid response, driving the valve open when needed, and steady-state positioning when recycling.

Engineered solution optimized for your application

When sizing and selecting the Valtek Compressor Anti-Surge Valve from Flowserve, we work with you to understand your compressor application requirements and offer an anti-surge control system capable of meeting compressor protective functions and all performance requirements as specified by the compressor manufacturer in an economical engineered to order (ETO) package.

The Valtek Compressor Anti-Surge Valve is comprised of the following key components. They have been engineered to work together seamlessly to protect critical compressors from surging.

- Mark 100SC™ angle body valve
- Logix 3800JF™ positioner
- MegaStream™ noise control
- Stealth™ noise control
- Linear piston actuators
- Actuator cushions
- SpiralTrack™ feedback

Typical applications

Flowserve designed the ASV control valve to succeed when facing the difficult challenges of LNG surge control applications. It is also suited for many other industries and applications. Typical applications include:

- LNG processing
- Natural gas transmission stations
- Refinery gas compression
- Olefin production
- Chemical plants using natural gas as feedstock
- Oil and gas exploration

An integrated system

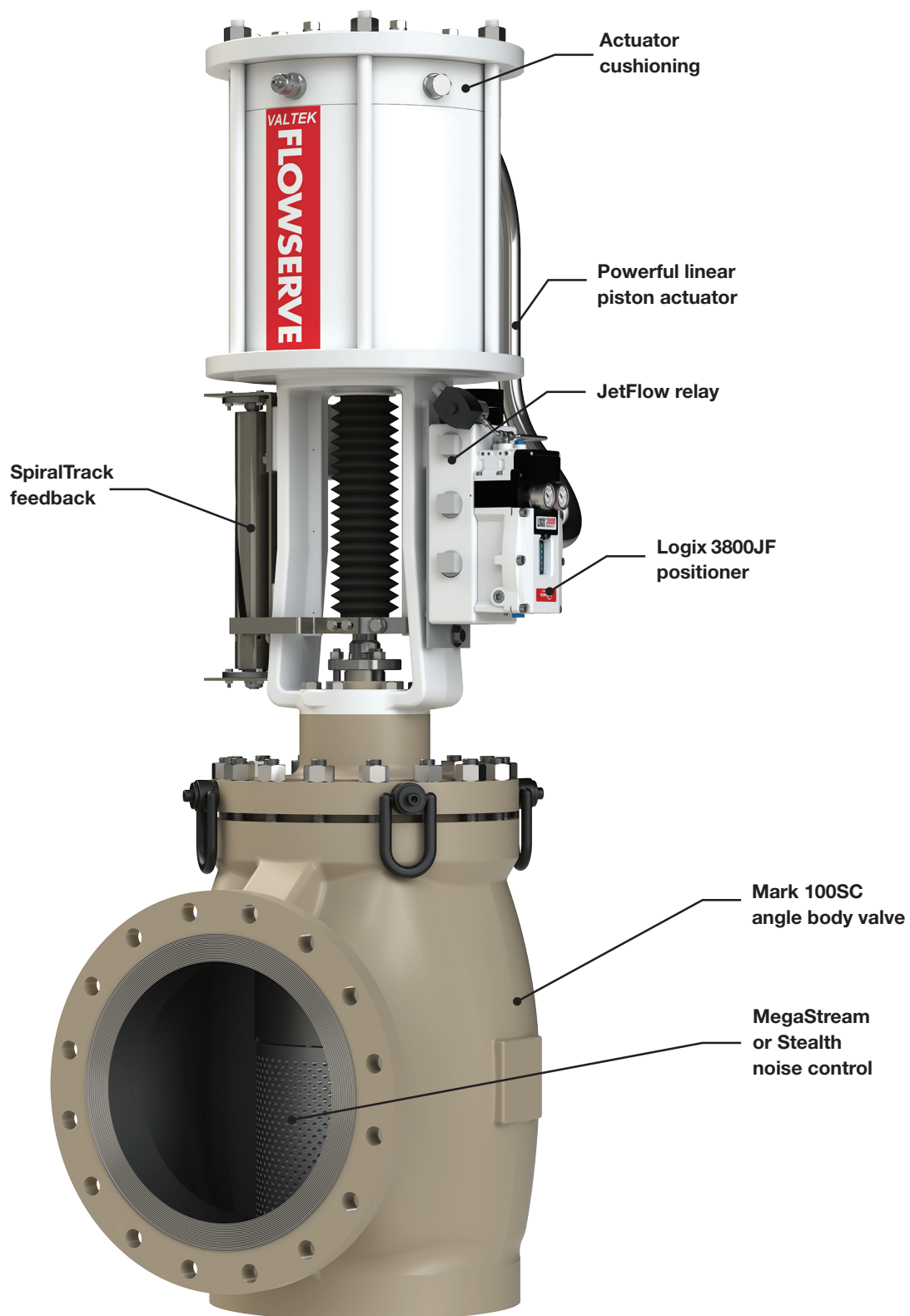

Actuator and positioner assembly

Improved speed and precision

The actuator assembly on the Valtek Compressor Anti-Surge Valve surge control includes the following key components, which work together to actuate the valve quickly and precisely.

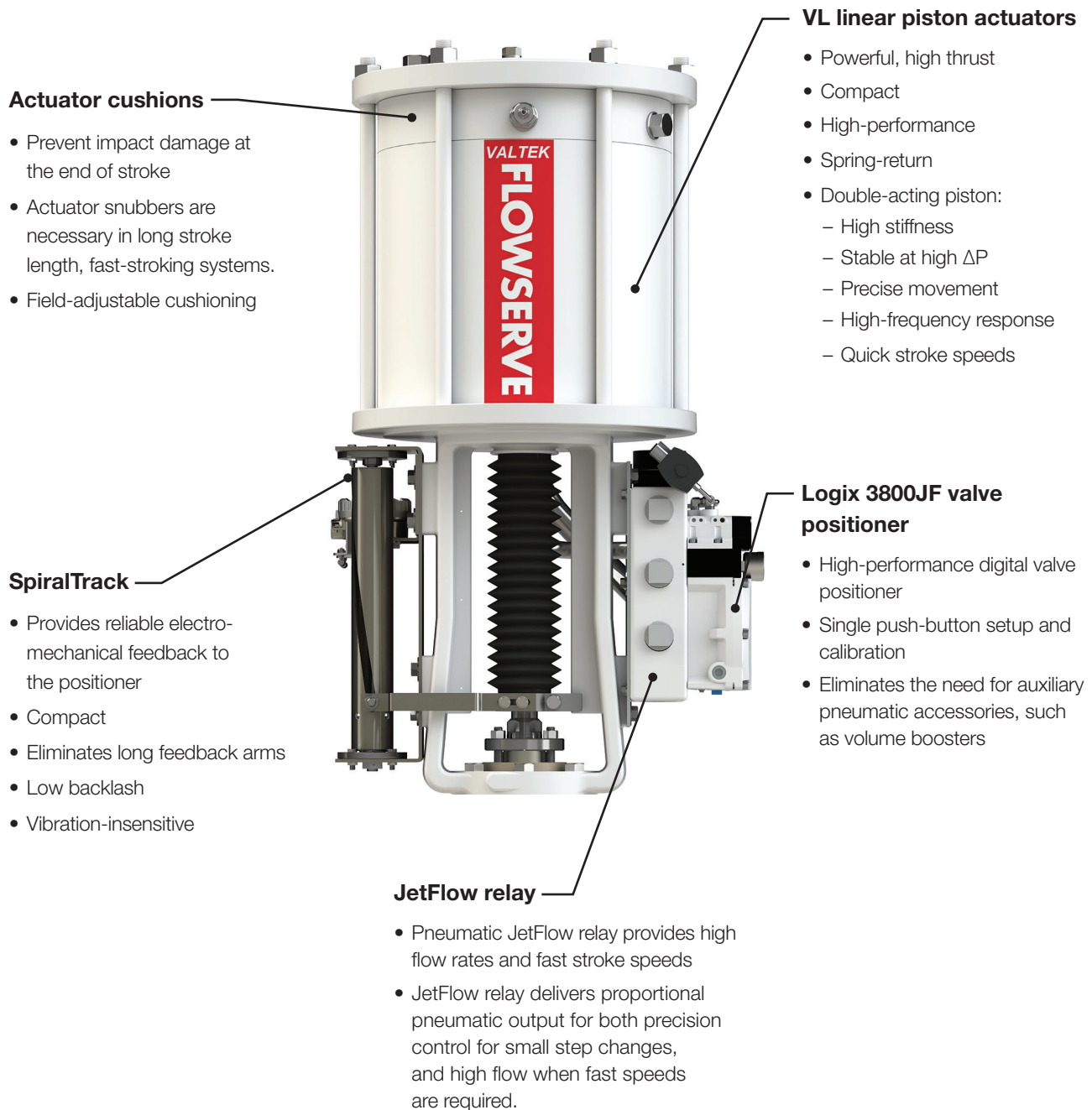

Precision control and fast stroke speed

The revolutionary Logix 3800JF positioner balances the needs of speed and precision, providing optimal performance for both. By applying a two-stage control loop for valve position and pneumatic JetFlow relay position, this intelligent positioner overcomes the conflict between precision and speed with reduced overshoot. The Logix 3800JF positioner delivers fast stroke speeds while still providing the fine control needed during recycle operation.

Reliable and simple to set up and tune

The Logix 3800JF positioner delivers reliable performance in harsh environments. The JetFlow relay contains only two moving parts, which reduces complexity and eliminates the need for volume boosters. Dynamic autotuning and commissioning of the valve are accomplished in minutes with a single push of the calibration button. As a loop-powered, two-wire device that runs on a 4-20 signal, it eliminates the need for additional field wiring and power sources.

Ease of maintenance and upgrades

Plant technicians can tune and repair the valve without relying on factory experts. The Logix 3800JF valve positioner allows easy upgrades through simplified retrofit with existing installations.

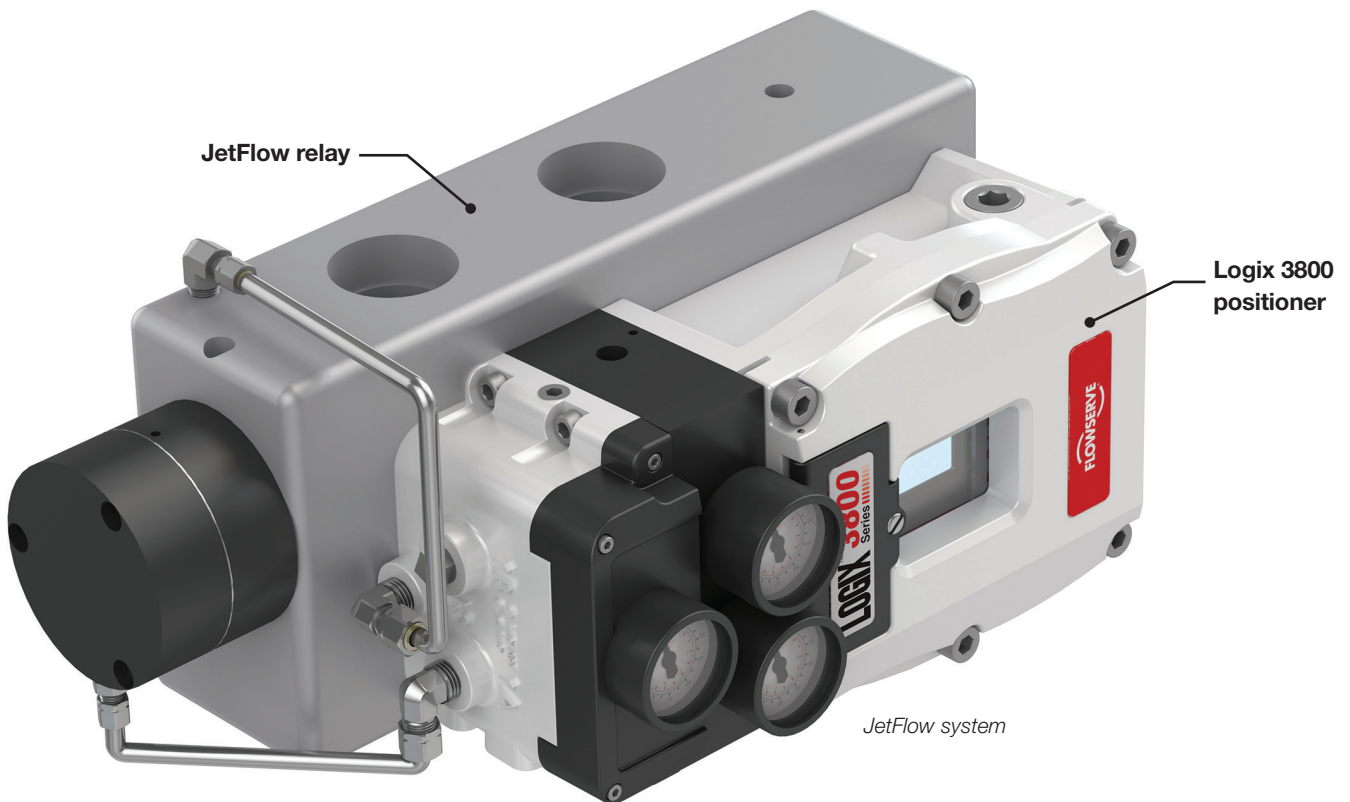

Valve body assembly

Exceptional capacity, noise and vibration control

The valve body of the the Valtek Compressor Anti-Surge Valve is designed for maximum capacity and noise control. Advanced trim designs minimize noise and vibration, reducing system wear, damage and downtime.

Mark 100SC angle body valve

- Delivers exceptional capacity, precise control and easy maintenance
- Large-volume gallery design is capable of providing 51 to 248% greater capacity compared to similar anti-surge offerings.
- Designed to accommodate severe service trims that reduce noise and vibration
- More accurate production process, less waste, fewer upsets and more revenue

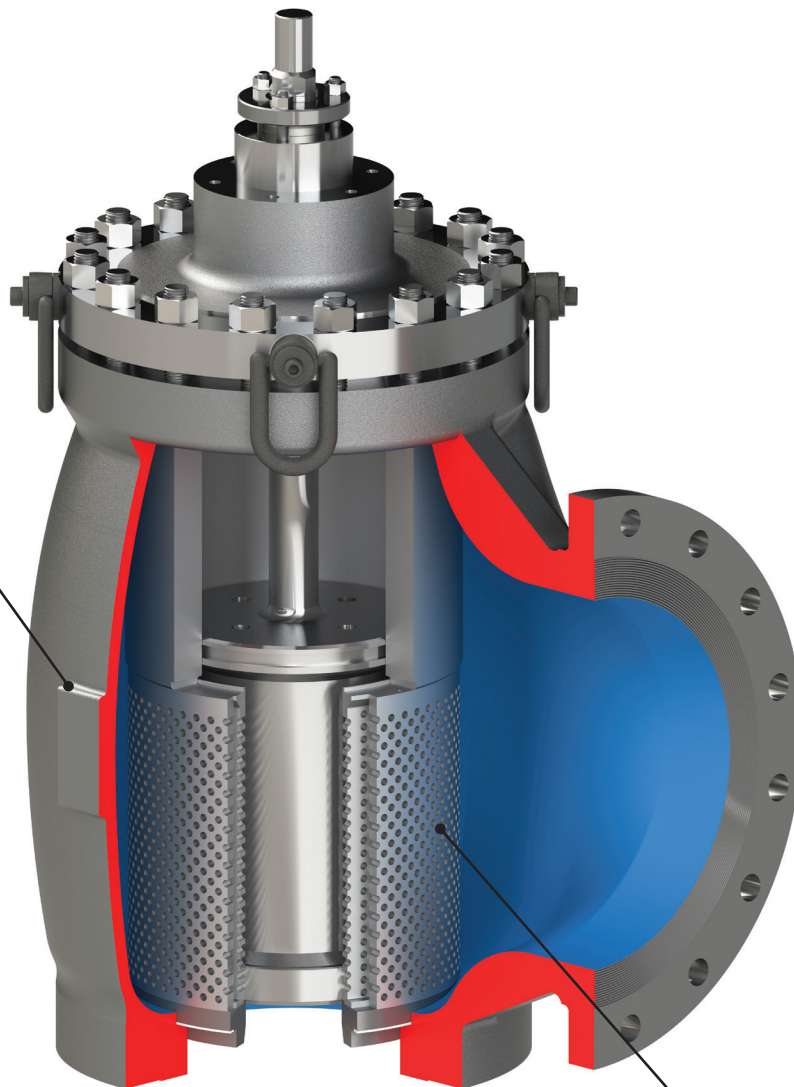

MegaStream noise control trim

- The advanced drilled hole design of MegaStream valve trim reduces valve noise by up to 30 dBA through:
 - Staged pressure drops
 - Frequency shifting
 - Staged attenuation
- Custom MegaStream trim flow designs balance controllability during recycle operations and maximum capacity.

Ease of maintenance and upgrades

The Flowserve compressor anti-surge control valve is durable and easy to maintain, reducing critical downtime and maintenance workloads.

Mark 100SC angle body valve

The Mark 100SC valve body delivers exceptional capacity, precise control and easy maintenance. Its large-volume gallery design is capable of providing 51 to 248% greater capacity compared to similar anti-surge offerings. It accommodates severe service trims that reduce noise and vibration in rigorous applications. Long stroke lengths deliver precision control, resulting in more accurate production process, less waste, fewer upsets and more revenue.

Noise and vibration control

Advanced noise control trim, such as MegaStream and Stealth, enable high flow rates while keeping emitted noise and resulting vibration levels low. Limiting noise reduces vibration, which can otherwise cause system wear or damage, and result in additional maintenance labor and costs.

Stealth noise control

The stacked disc Stealth trim is the most effective noise elimination technology available. Stealth trim delivers noise attenuation of more than 40 dBa through:

- Multiple pressure drop mechanisms
 - Turns, expansion-contraction, impingement, turbulent mixing, merging and splitting, small passage friction
- Passive noise cancelation
- Frequency shifting
- Controlled jet spacing at discharge

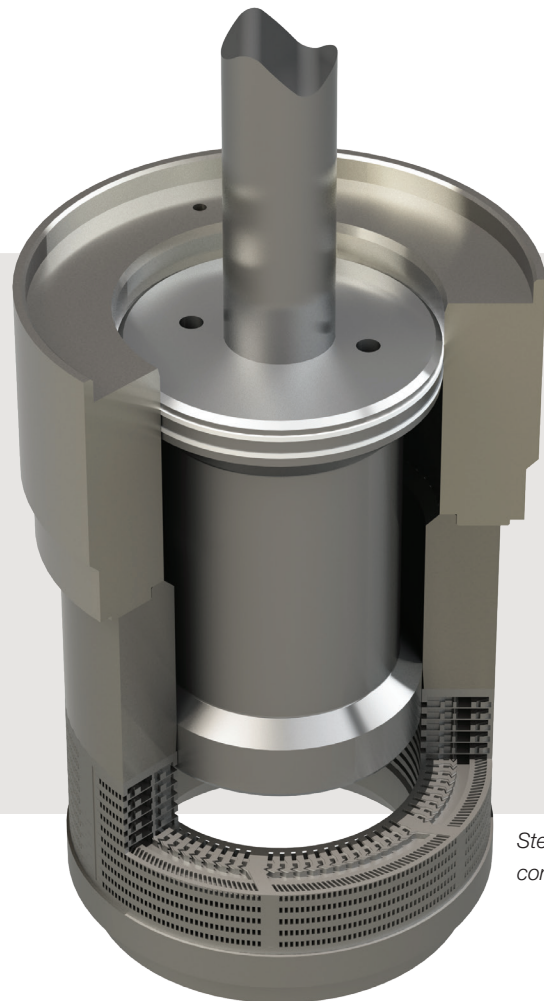

Stealth noise control trim



Mark 100SC valve body specifications

Selection	Description
Sizes	8 to 30 in
Pressure Class	150#, 300#, 600#
Body Configuration	Angle valve
Body Materials	Carbon steel, stainless steel, chrome moly
Trims	Noise control trims: MegaStream, Stealth
Actuation	VL family of actuators: spring-cylinder linear; pneumatic actuator

Flowserve Corporation
5215 North O'Connor Blvd.
Suite 2300
Irving, Texas 75039-5421 USA
Telephone: +1 937 890 5839

Flowserve Corporation has established industry leadership in the design and manufacture of its products. When properly selected, this Flowserve product is designed to perform its intended function safely during its useful life. However, the purchaser or user of Flowserve products should be aware that Flowserve products might be used in numerous applications under a wide variety of industrial service conditions. Although Flowserve can provide general guidelines, it cannot provide specific data and warnings for all possible applications. The purchaser/user must therefore assume the ultimate responsibility for the proper sizing and selection, installation, operation, and maintenance of Flowserve products. The purchaser/user should read and understand the Installation Instructions included with the product, and train its employees and contractors in the safe use of Flowserve products in connection with the specific application.

While the information and specifications contained in this literature are believed to be accurate, they are supplied for informative purposes only and should not be considered certified or as a guarantee of satisfactory results by reliance thereon. Nothing contained herein is to be construed as a warranty or guarantee, express or implied, regarding any matter with respect to this product. Because Flowserve is continually improving and upgrading its product design, the specifications, dimensions and information contained herein are subject to change without notice. Should any question arise concerning these provisions, the purchaser/user should contact Flowserve Corporation at any one of its worldwide operations or offices.

©2020 Flowserve Corporation. All rights reserved. This document contains registered and unregistered trademarks of Flowserve Corporation. Other company, product, or service names may be trademarks or service marks of their respective companies.

VABR000051-01 (EN/AQ) July 2020