



USER INSTRUCTIONS

Edward Valves

Cast Steel Bolted Bonnet Valves

FCD EVENIM2004-03-AQ – 10/15 (Replaces V-380 R2)

*Installation
Operation
Maintenance*



Contents

Introduction	3
Service Problems	3
Repair Procedures	6
Disassembly Procedures	9
General Information	14

Introduction

Cast Steel Bolted Bonnet

This manual has been prepared to serve as a guide for the maintenance of Edward bolted bonnet valve construction. It is designed to help you in obtaining the most satisfactory service from these valves.

Although rigid metallurgical, physical and visual inspection is the standard procedure for all Flowserve products, it is inevitable that some valves, after a period of time, may occasionally require repair. When this happens, this manual will assist you so that your valve may be satisfactorily restored to good working condition with a minimum of time and expense.

Before starting, it will be helpful to have some understanding of the valve's physical construction. The drawing on page 5 will give you some idea of how the valve is put together.

The next major section of this manual discusses the more common service problems and failures. It identifies the problem and explains the reasons for certain failures.

The reason should be understood before work is actually started.

Then the procedure to be followed in making the repair is explained. This includes normal valve maintenance as well as major valve repair. Field repair equipment, available from Flowserve-Raleigh, is described and illustrated. Valve lubrication and welding rod recommendations are also made. These procedures are adequate for almost any valve repair or maintenance problem that may arise in the field.

The next major section describes the disassembly procedures for the various valve components.

It is very important that the Introduction and the paragraphs titled "First Determine the Area of Failure" be read and understood before any disassembly work is begun. Several procedures are described, depending upon the area of failure.

Considerable time can often be saved by first selecting the proper disassembly procedures.

The last major section explains how the various valve constructions are to be reassembled. Information on how to contact Flowserve-Raleigh for additional advice, if required, and how to order parts is included.

Figure number of Edward bolted bonnet valves described in this manual:

302	329Y	605Y	1324
302Y	390	618	1324 Y
303	390Y	618Y	1390
303Y	391	619	1390 Y
304	391Y	619Y	1392
304Y	392	670Y	1392 Y
318	392Y	690	1441
318Y	393	690Y	1441 Y
319	393Y	691	1443
319Y	394	691Y	1443 Y
328	394Y	1302	1641
328Y	604	1302 Y	1641 Y
329	604Y	1314	1643
605	1314 Y	1643 Y	

Service Problems

Packing Chamber Leak

Where moisture appears or actual dripping occurs at the packing chamber around the stem, gland or gland flange which cannot be eliminated by re-torquing the gland bolt the following points should be considered.

1. The packing may have become hard. Replace the packing.
2. Gland travel has been fully taken up. Repack with new packing.
3. The wrong packing is being used. See packing recommendations shown on this page.
4. A stem should be replaced when it has become deeply scratched, burred, or otherwise mutilated from careless handling, or where the stem has worn, tapered or has been bent.
5. The gaps in the rings of split packing have not been staggered around the stem. They should be inserted in this manner.
6. The packing gland may be binding against the packing chamber or stem and does not compress the packing properly. Make certain the gland fits the packing chamber and is tightened down equally on each side.

Packing Recommendations

Edward valves are packed with all-purpose packing sets. This is a combination of packing using braided rings at the top and bottom of the packing chamber and flexible graphite packing in the center section. Packing glands should be tightened down enough to prevent leakage but not enough to develop excessive operating torque.

When the gland has advanced approximately half way into the packing chamber, it is recommended that additional packing rings be added. To obtain best results, the stem should be thoroughly cleaned.

Replacement packing should be the same as that originally furnished.

We recommend that replacement packing be purchased from Flowserve-Raleigh, to assure packing with the proper density and corrosion inhibitors is always used.

NOTE: Long service life from modern graphitic packing requires that adequate preloads be applied when repacking.

1. All parts should be clean and not scored or pitted, especially the stem.
2. The valve internal parts and bonnet should be assembled prior to installing the packing.
3. Position split packing rings with the ends of adjacent rings rotated 90°.
4. Install in the following sequence:
 - Bottom Ring – Braided Ring
 - Center Rings – Die formed expanded graphite
 - Top Ring – Braided Ring
5. Clean and lubricate the gland eyebolts.
6. Carefully seat each individual packing ring before adding the next ring.
7. Apply the recommended torque to the gland nuts evenly without cocking the gland. See Table A for recommended torques.
8. Tighten the nuts to the initial values shown, then loosen and re-tighten to the final torque.
9. Stroke the valve, then re-check the gland nut torques.

Table A: Gland Bolt Torques, Ft-Lbs

Figure Numbers	Size	Initial Torque	Final Torque
328, 328Y, 329, 329Y, 1441, 1441Y, 1443, 1443Y	2.5	24	6
	2.5	24	6
	3	27	6
302, 302Y	4	27	6
303, 303Y	5	41	9
304, 304Y	6	55	13
318, 318Y	8	60	14
319, 319Y	10	89	21
	12	143	33
	6	40	9
1302, 1302Y	8	68	16
1314, 1314Y	10	76	18
1324, 1324Y	12	140	32
1641, 1641Y 1643, 1643Y	2.5	24	7
	2.5	27	8
604, 604Y	3	27	8
605, 605Y	4	41	12
618, 618Y	5	55	16
619, 619Y	6	60	17

Bonnet Gasket leak

A torque wrench should be used for tightening the bonnet or cover retainer studs or cap screws which are used to preload the soft iron gasket.

The following procedure is recommended:

1. Guard against leakage by having these bolts tight at all times.
2. With line pressure in the valve, all nuts or cap screws should be tightened to the torque shown below.

Bolt diameter, Inches	½	9/16	5/8	¾	7/8	1	1 1/8	1 ¼
Torque, Ft. Lbs.	45	68	90	150	240	370	585	750

Should the leak fail to stop after tightening, it must be concluded that there is an imperfect seal, and the valve will have to be opened for examination. Such a leak may result from either of the following causes:

1. **Incomplete Seal Between Bonnet and Gasket or Body and Gasket.** An incomplete seal around the gasket seating surfaces may be caused by corrosion, dirt, chips, or other foreign matter on the mating surfaces. An incomplete seal may be caused by surface imperfections in the body or bonnet surfaces in the form of pin holes, extended cracks, or indentations where the metal has failed sometime after valve installation and use. Such imperfections may be surface indications of deeper flaws in the body casting which may cause a by-pass around the gasket.

- Leakage at the Gasket. The possibility of a leak through the gasket itself, while remote, should still be considered. This may not be the result of external flaws on the sealing surfaces of the gasket.

Seat and Disk Joint Leak

A leak existing between the seat and disk of a closed valve might be indicated by one of the following: a definite pressure loss in the high-pressure side of the valve; continued flow through an inspection drain on the low-pressure side; or, in hot water or steam lines, a downstream pipe that remains hot beyond the usual length of time and conductivity range.

Such a leak may be the result of a distorted seat caused by uneven welding and stress relieving temperatures that were present in the body when mounting the valve in the pipe line. It may also develop because of the operator's failure to close the valve tightly. An increased velocity is imparted to a flow forced through a very small opening. This increased velocity subsequently gives rise to the "cutting" of both disk and seat, particularly by particles of line scale or rust in suspension or normal solids in solution; or, in spite of the fact that the hard sur-

facd material on the seat and disk is corrosion and erosion resistant, grooves, pit marks, or other surface irregularities may be formed on the seat and disk joint surfaces when the disk is closed against a foreign body on the seat. This sometimes occurs during the initial start up of a piping system.

Leakage of steam through a valve which is badly steam cut has a whistling or sonorous sound. If the valve is only slightly steam cut, however, leakage is identified by subdued gurgling or weakly popping sounds. These sounds can be heard through a stethoscope or by placing one end of a stick against the valve body while holding the other end between the teeth, with hands over the ears.

Body Wall Leak

This is a visual leak through the body wall, welding end or end flanges and may be the result of a shrink cavity or other void in the casting. If small at first, such a leak may go unnoticed for a time, particularly if the valve is heavily insulated and the pipeline at that point is sufficiently warm to keep the insulation dry enough to escape notice.

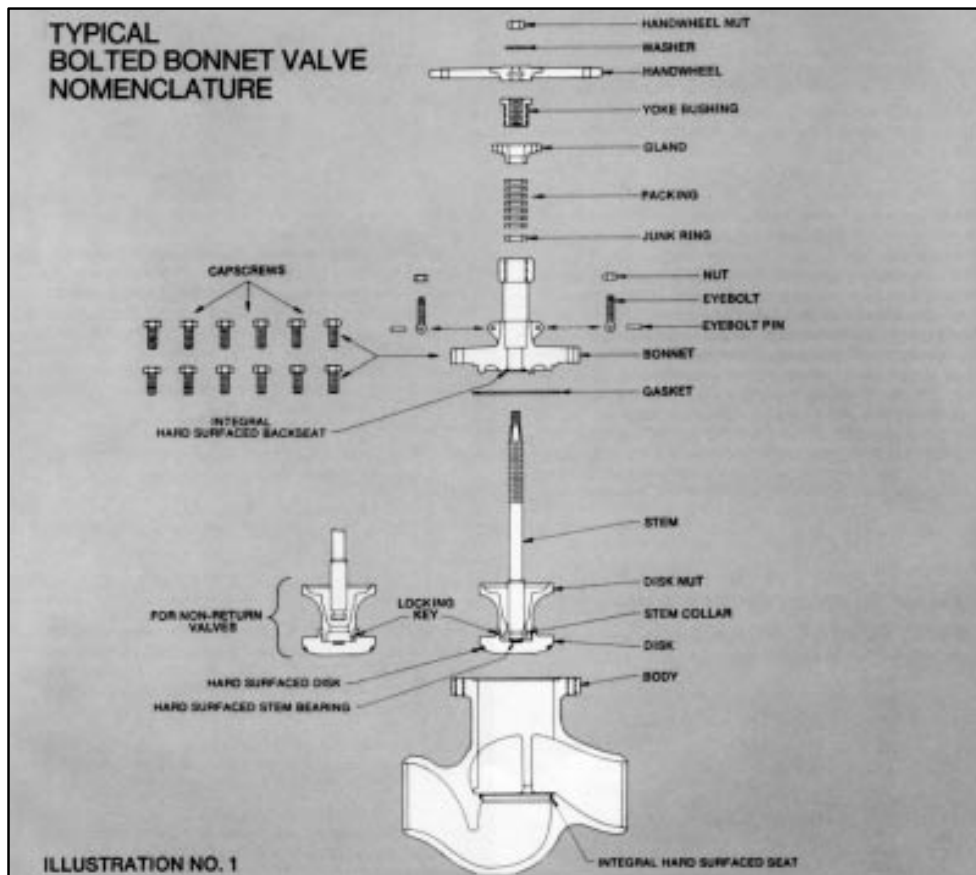

Objectionable Vibration Noise or Excessive Pressure Drop

Excessive vibration noise or humming coming from within a stop-check (non-return) or check valve indicates the possibility that the disk-piston assembly is wedged inside the body. Such sticking may be caused by uneven body guide rib wear on the downstream side induced by oversizing the valve, by corrosion, by flakes of line scale, or by particles of weld spatter that may have entered the valve during construction of the piping, and which later washed up into the piston bearing area of the body I.D.

The stem of a stop-check valve should normally be fully open in order that the disk-piston can lift the full amount. When the disk is not touching the bottom of the stem or the bottom stop lugs on the bonnet (due to a wedged disk piston or insufficient flow, for example), then the disk assembly is free to move laterally within the body.

This motion in most cases causes a slight vibration which can be felt through the body, bonnet and handwheel. Screwing the stem down slowly to contact the disk first increases the intensity of vibration to the hand and to the ear, but further downward movement of the stem builds up sufficient contact pressure and eliminates the vibration. This also tends to dislodge any foreign particles which may have been the initial cause for disk-piston wedging.

The position of the stem where vibration ceased, should be noted and any increase in pressure drop indicated on available gages, recorded. It may be that when the stem is screwed back to the full open position, the disk will again remain in a floating position which could indicate oversizing of the valve for the flow conditions. It is always recommended that check valve size selection be governed by flow conditions rather than by adjacent piping. Oversizing induces vibration or noise and causes excessive, uneven guide rib wear giving rise to greater disk-piston assembly clearance on one side of the body.

Another way to dislodge a wedged piston is to use other valves in the line. If possible, vary the rate of flow through a noisy check valve sharply enough (in a short period of time) to dislodge the piston from its wedged position.

Lubrication

In order to obtain full service life, valves require periodic lubrication of the bearings and stem threads, as does any rotating machinery.

On valves where the stem bushing and bearings are in the motor actuator, the bearings are lubricated by the actuator lube supply, which should be maintained at the recommended level.

- 6** Stem threads also require periodic replenishment of the lubricant. Exposed threads should be wiped clean of old grease and accumulated dirt and fresh lubricant applied. This is most effectively done with the valve in the closed position.

For valves that see frequent operation, the lubricant should be replenished on bearings and stem threads every three months. If extreme service conditions dictate, the plant operating engineer should establish a more frequent re-lube schedule.

For valves that are operated infrequently, relubrication at least once a year is recommended. The recommended lubricant for stem threads is Rykon EP #2, manufactured by The American Oil Company. This is an extreme pressure, extreme temperature lubricant of high quality.

Repair Procedures

Body Bore Guide Rib Repair

Where more than one guide rib is involved, each rib should be preheated and welded before proceeding to the next.

1. Prior to any cutting or welding operations being performed on the valve, it is necessary that adequate seat joint protection be provided and some means of insurance against getting chips, weld spatter or other foreign matter into the pipe line, if the valve is permanently mounted. A round piece of sheet metal placed over the seat and taped in place will furnish adequate protection.
2. Chip out the defective area in the body, being careful to remove the affected portion to its end, inside the casting, and to thoroughly clean it away.
3. With a small hand grinder, grind the chipped area smooth.
4. Heat the body area adjacent to the guide rib to 200°F. This can be done locally with an oxyacetylene torch.
5. Select the proper welding rod to suit the body material (1/8" maximum size rod is recommended here). See Table B, page 8, for weld rod recommendations. Because of slag conditions and easy maneuverability, class 7010 rods are recommended. If replacing stainless steel inlay, use AWS 5.4 E309L stainless electrodes.
6. The welding should be started at the bottom so as to create a small shelf, and then proceeded up the guide rib. Lay the weld in thin, even layers, peening each layer before proceeding with the next, and being careful to maintain a temperature of 200°F in the area being repaired. Peening the bead actually stretches it and counteracts its tendency to contract and shrink as it cools. The last layer of weld must overlap onto the sound metal to ensure a weld without an undercut at the edges. The overlapping should be done along this edge by using a welding rod of 1/8" maximum diameter. The last layer should bring the height of the welded area up to 1/16" above the original surface, as checked with a straight edge along the body bore.

For this type of weld repair, it is recommended that the last layer be pounded while still hot with the flat face of a hammer. Thermal

stress relieving is not recommended.

7. With a hand grinder, rough grind the welded surface to within about .010" of the finished surface. The edges of the guide ribs should be rounded off smooth. Check the progress of the rough grinding by using a straight edge and feeler gages. As the bonnet bore and guide rib approach alignment, a light can be placed on one side of the straight edge and the high spots in the guide rib observed on the other. Where a check valve or stop-check (non-return) body is being repaired, the progress of the finishing cuts can also be measured by slipping some long pieces of shim stock between the I.D. of the body guide ribs and the O.D. of the disk-piston assembly, which has been placed centrally in position on the seat joint. A shim should pass around the disk at all three guide ribs with equal clearance.

The disk-piston assembly should also be moved up and down to make sure that it is free.

It is recommended that where guide rib repairs have been made, the seat and disk joint be checked for distortion and relapped, if necessary.

Seat and Disk Repairs

A valve seat joint will require repairing in any instance where the seating surface permits a leak because it has been altered from the original state in which it was shipped from the factory; where corrosion has set in to cause pit marks on the seating surfaces of either the body or disk, where the seat has become distorted because of an abnormal heating condition; or, where a groove has been formed on the seat or disk by closing the valve against a foreign body. Verification of such a faulty condition may be obtained by a seat bluing test or by careful visual examination.

The hard surfaced seats in these bolted bonnet valves are not easily scored, but where reconditioning is necessary, the following points should be observed:

Where an indentation or pit marks on the valve seat joint are deep (.010 or greater), a cast iron lap with suitable lapping compound will speed up repair. The cast iron lap should be closely guided in the body bore during the lapping.

Lap first with the cast iron lap and finish with the valve disk, which has been reground or relapped, if necessary. For initial lapping, use Clover compound "A", Norton 320 mixed with olive oil or sperm oil to a molasses consistency is recommended for finish lapping. For rough lapping, Carborundum H20 coarse is recommended.

In the lapping operation, lap against the seat with a small quantity of the lapping compound placed between the mating surfaces. It is important that not too much pressure be applied on the lap or disk against the seat. With the lapping compound in place between the mating surface, the lap or disk should be reciprocally rotated as far as arm movements

will permit while standing in one position: the strokes should be light, and the lap or disk should be lifted frequently and turned to a new position circularly around the valve body so that lapping will be rotated over a new area. To make certain the pressure strokes are light, it is necessary on large valves to suspend the disk and stem assembly from a coil spring in such a manner as to allow the disk to bear, but lightly, against the seat. See Figure A page 9.

For smaller size valves, a driving handle can be easily made of 3/8" diameter wire bent as per Figure B. These small assemblies, being much lighter, do not require a supporting spring. Hard surfaced seating faces are hard and lapping time is variable, depending on the extent of flaws on the surface and the position of the valve in the line. If a seat requires machining prior to lapping, portable boring machines are available from Flowserve-Raleigh.

The disk of stop valves may also require refinishing. When the only defects that can be found on the disk-stem assembly occur on the seating surface, it becomes very convenient to push the stem into a lathe spindle and chuck on the disk nut diameter without taking the assembly apart. (However, if the stem is too large to fit through the lathe spindle, it will have to be taken apart as described in the following paragraph.) Hold the disk using a four jaw chuck so that the large O.D. and seating surface run true. Grind the seating surface using a tool post grinder. Just go deep enough to clean the surface. Polish the seating surface with fine emery cloth.

If when checking the disk stem assembly, it is found that the assembly is tight or does not swivel freely, it will be necessary to disassemble.

The lock key weld and locking key can be drilled out. After the key has been removed, the disk nut can be readily unscrewed. Repair any damage surfaces on the stem, disk nut, stem collars or disk. Then proceed to repair the disk seating surface as described above. When finishing the disk in this manner, it will not be necessary to lap it to the seat.

Body Wall Repairs

There are five basic steps in repairing a casting defect:

1. Cut out to sound metal. Attempting to weld over the defect will only leave a notch that may re-introduce the defect. Cutting may be done by chipping, grinding or flame gouging. The amount of metal removed should be held to a minimum to avoid distortion during subsequent welding.
2. Preheat, using the minimum temperature specified by the material specification and / or the design code. Use at least 400F on WC9 or C5 material, 300F on WC6. Although cast carbon steels such as WCB or WCC do not require preheat, it may be advantageous to remove any moisture or other contaminants from the area to be welded. This may also identify any leak paths. There are also disadvantages to preheat, especially localized preheat, that must be considered when working in areas of the casting with finish

machined dimensions. Distortion may result in more damaging problems than those concerns created by the original defect. Lower preheats and the control of interpass temperature are two methods used to minimize distortion.

3. Welding should be done by qualified welders, using qualified procedures and weld material of a chemistry matching the casting (see Table B for welding rod recommendations). The final weld should be blended into the contour of the casting.
4. Stress relieving is generally recommended. Decisions to not stress relieve should factor in piping code rules. The temperatures must be based on material specification and piping code recommendations. Again, since temperatures are much higher than those experienced in welding, there are also disadvantages that must be considered. Distortion may result in more damaging problems. Lower temperature postweld heat treatment is sometimes an option for carbon steels.
5. The final weld should receive any needed nondestructive testing. This should include a visual examination and liquid penetrant or magnetic particle examination. Some major weld repairs could even mandate radiography to ensure a sound weld.

Valve Component Repair — Disk-Piston Assembly Repairs

It is possible that the bearing surfaces on the O.D. of the disk-piston assembly and I.D. of the body can become scored deeply enough to cause a binding or wedging of the piston assembly in a full, or partially open or closed position. Such scores and resulting burrs may be caused by particles of weld spatter, flakes of hard line scale or other foreign matter which has inadvertently gotten into the line. Upon disassembly burrs must be removed with emery cloth, and the bearing surfaces otherwise made smooth and clean again. Where the burrs on the piston are very large, it may be more convenient to chuck the assembly in an engine lathe and file them off.

Gasket Seal Area Repair

Where foreign matter of any sort is responsible for a gasket seal leak on the sealing surface of the bonnet, it is very likely that it has caused an impression in the same sealing surface which must be removed completely before reassembling. This can be done by taking a shaving or skin cut on the sealing surface. In so doing, it is mandatory that the work be chucked and square to all existing diameters and surfaces.

Table B – Welding Rod Recommendations

Material To Be Welded			Weld Rod Recommendations
ASME IX P-#	Material	ASTM Grade	AWS Classification
P-1	Carbon Steel	1. ASTM A216 , Grade WCB 2. ASTM A105	AWS 5.1 E7018
P-4	1¼ % Chromium, ½ % Molybdenum Low Alloy Steel	1. ASTM A217 , Grade WC6 2. ASTM A182 , Grade F11	AWS 5.5 E8018-B2
P-5	2¼ Chromium, 1 % Molybdenum Low-Alloy Steel	1. ASTM A217 , Grade WC9 2. ASTM A182 , Grade F22	AWS 5.5 E9018-B3
P-8	18% Chromium, 8% Nickel Stain- less Steel	1. ASTM A351 , Grade CF8M 2. ASTM A182 , Grade F316	AWS 5.4 E316
P-8	18% Chromium, 8% Nickel Stain- less Steel	1. ASTM A351 , Grade CF8C 2. ASTM A182 , Grade F347	AWS 5.4 E347

Welding Edward Valves In-Line

When welding a valve in line, the installer should apply the specific technical rules imposed by the jurisdictional authority of the area where the valve is installed, In the absence of such rules, following are suggested practices for welding Edward valves in line:

1. Welding should be done using procedures and personnel qualified in accordance with ASME Section IX. Rules for preheat and post-heat are stated in Chapter V of ASME B31.1 (Power Piping).
2. The valve should be welded in line, one end at a time, in a closed position (approximately a half-turn after the seat in the body comes in contact with the disk). This is suggested to preclude warpage between seating surfaces caused by temperature induced stresses during welding or subsequent heat treat. It also protects the seat from weld spatter that might coat the lapped seat and disk. When postweld heat treat is required, each weld end should be heat treated one at a time, to minimize impact of heat on valve internals. Do not heat treat an Edward valve with a piping attached as a unit in a furnace, as warpage of parts may occur. After welding, open the valve and flush the line to clean out all foreign matter.

Field Repair Equipment

Available from Flowserve-Raleigh are some basic tools for repairing valves in the field. This equipment was developed for customer use on a rental basis. Of course, an emphasis has been placed on large valve repairs where economics justify extensive repairs in the field rather than removing the valve from the pipe line for return to the factory. Contact your local Flowserve-Raleigh sales representative for more information. A list of this equipment follows:

1. Lapping equipment. See Illustration No. 2.
2. Self-centering lap guide fixtures for lapping valve seats in valves 8" and up. See Figure C. This fixture can be used when the valve is installed in any position, and is recommended, when the stem is horizontal.
3. Sunnen Portable Hone for honing bores from 4 " to 14-1 / 2 " diameter. (Not illustrated)
4. Van Norman portable boring machine for reboring valves in the field. Grinding attachments are also available for some sizes for grinding seat joints. (Not illustrated)
5. Air driven portable boring machine for reboring guide ribs and seats of valve bodies in the line. (Not illustrated)

Disassembly Procedures

Disassembly Procedures For Bolted Bonnet Valves Introduction

Step-by-step disassembly procedures are described for all types of Edward bolted bonnet valves, including those with manual and motor actuators.

It is important that the following paragraphs be read and understood before specific disassembly work is started.

First Determine The Area Of Failure

Failures or maintenance problems, for other than check valves, can be divided into two major areas. The area involved will affect the disassembly procedure to be followed. These areas, in general, are:

Area 1

The impactor Handwheel or Handle, or the Limitorque Actuator.

Area 2

The valve internals, including the bonnet, body, stem, disk, disk-nut, gland and seats.

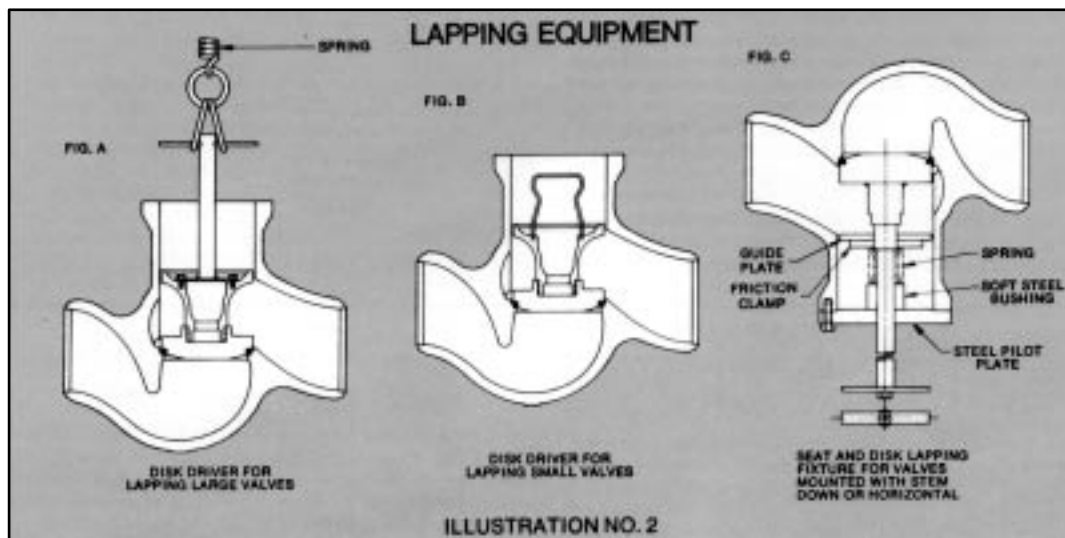

▲ CAUTION: As a general reminder, make sure all pressure is removed from valves, both upstream and downstream, before any disassembly work is started. An exception to this is valves requiring service only on the actuator (Area 1) where the valve can remain in service.

1. For service in Area 1:
 - a. If pressure is to be maintained in the valve, fully close the valve or backseat in full open position. On electric operated valves with non-revolving stems, the valve must be backseated in the full open position only.
 - b. If no pressure is to be maintained in the valve, close the valve fully and open approximately 1/8".
2. For service in Area 2:

Close the valve fully and open approximately 1 / 8 ". Service Area 2 only without pres- sure in the valve.

If Failure Is Indicated In Area 1

Refer to the applicable section “Disassembly Procedures for Impactor Handwheels,” or “Procedures for Removing Electric Actuators from Valve Bonnets”.

If Failure Is Indicated In Area 2

Two methods are available. In Method 1, the actuator and bonnet assembly may be removed from the valve body as a unit.

This requires less time but requires adequate clearance area above the valve. The second method is to first remove the actuator from the bonnet, and then the bonnet from the body, in separate steps.

For Method 1, leave the valve actuator mounted on the bonnet and follow instructions for “Disassembly Procedures for Valve Parts,” page 12.

For Method 2, first remove the operator by following the applicable section, “Disassembly Procedures for Impactor Handwheels” or “Procedures for Removing Electric Actuators from Valve Bonnets”. Then proceed to the section, “Disassembly Procedures for Valve Parts,” page 12.

If failures are indicated in any combination of Areas 1 & 2, then each of the respective procedures must be followed . For check valves without stems or actuators, simply use the proper section under “Disassembly Procedures for Valve Parts,” page 12.

Disassembly Procedures For Impactor Handwheels Area 1

Edward valves use several designs of Impactor handles or handwheels, depending upon the valve size and pressure class.

Handwheels can be removed while the valve is pressurized. If under pressure, the valve should either be fully closed or backseated in the full open position

Impactor Handles And Handwheels

Not illustrated, but of similar construction to Illustration No. 4, page 11, are Impactor handles. The following instructions apply, in general, to all.

1. Remove the handwheel lock nut, which is the uppermost part on the top of the valve stem. On some designs, it is a friction device and is merely unscrewed. On others, a roll pin must first be driven out. On another design, a small lock screw must be unscrewed.
2. Mark the relative position of the handwheel and crossarm so the original relationship can be restored when reassembling. If this is not done, the handwheel could be reassembled 180 ° out of the original position.
3. Lift the handwheel off the valve, using a suitable capacity chain hoist for large handwheels. If the stem of the valve is mounted vertically, position the hoist directly above the handwheel, Otherwise, the hoist should be positioned slightly away from the handwheel in line with the stem.
4. Crossarm Removal: For all valves, the crossarm can be removed by tapping lightly with a hammer on the underside and lifting off.

Procedures For Removing Electric Actuators From Valve Bonnets

Edward bolted bonnet valves use various types of electric actuators, depending upon the size and pressure class, which determine the torque requirements, whether the stem is revolving or non-revolving and whether the valve takes the stem thrust (torque only unit) or the actuator takes the stem thrust (torque and thrust unit). The procedures below describe the removal of these various types from the valve bonnet. Also included are complete instructions for resetting the limit switches.

Disassembly procedures for the electric actuators themselves are not included and appropriate instructions should be obtained before starting. Consult the actuator manufacturer.

The actuator can be removed while the valve is pressurized but caution must be observed to make certain that the valve is first in the back-seat-ed or fully open position before removing units from valves with non-revolving stems. See “Caution,” page 10.

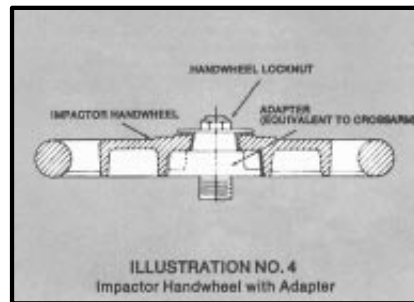
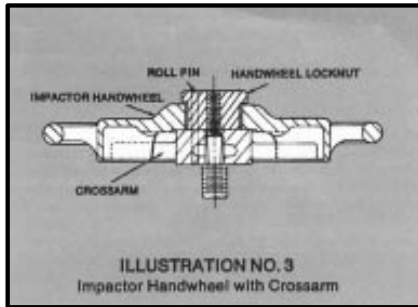

NOTE: All of the following disassembly procedures are arranged in accordance with the general comments of page 10. Study these pages carefully before beginning. Determine first whether the valve stem is revolving or non-revolving.

Revolving Stem Valves

On revolving stem valves the actuator drive nut is connected to the stem through a key. See Illustration No. 5, page 12.

1. Disconnect the electrical wiring to the actuator.
2. Position a sling on the motor actuator and attach a chain hoist of suitable capacity to the sling.
3. Remove the nuts or cap screws from the underside of the actuator flange.
4. Lift the actuator up and completely off the stem and stem key.
5. Position the actuator away to a clean area for further disassembly, if required.

Non-Revolving Stem Valves

On non-revolving stem valves, the actuator drive nut is threaded to the stem. See Illustration No. 6, page 12.

1. Disconnect the electrical wiring to the actuator.
2. Make certain the packing gland nuts are tight.

3. Position a chain hoist of suitable capacity so the actuator is supported in such a manner that the handwheel can still be rotated. If the valve is installed with its stem other than vertical, the hoist should be positioned slightly away from the handwheel in line with the stem.
4. Remove the nuts of cap screws from the underside of the actuator flange.
5. Turn the actuator handwheel in a direction to close the valve, thus unscrewing the actuator from the stem. Try to keep the weight on the hoist as the handwheel is turned to prevent damage to the stem threads.
6. With the hoist, lift the actuator clear of the stem and place down on clean area for further disassembly, if required.

Electric Actuator Limit Switch And Torque Switch Setting Procedures

The following procedures are intended as a general guide for setting limit and torque switches on electric actuators. For specific instructions, refer to the appropriate actuator instruction manual or consult the actuator manufacturer.

Geared Limit Switch

When mounting or re-mounting an electric actuator, the geared limit switch must be reset as follows:

1. Make certain the electric current is off.
2. Open valve by hand until the stem strikes the backseat.
3. Mark the stem and reclose approximately 1 / 8 " to allow for coast of the moving parts.
4. With the valve in this position, set the opening limit switch as outlined in the actuator instruction manual.
5. Connect the electric current and check this setting as follows:
 - a. Run the valve to mid-position by hand.
 - b. Press the “open” push button-make sure the valve is moving in the “open” direction.
 - c. Allow the limit switch to stop the motor.
 - d. After the motor has stopped, turn the valve by hand to make certain there is sufficient clearance between the position at which the valve stem comes to rest and the valve backseat.
6. To set the position for operation of the indicating light, make sure the torque switch is properly wired into the closing circuit and run the valve to the closed position. Back the valve off the seat to the desired position and set the “closed” light using the procedure outlined by the actuator manufacturer.

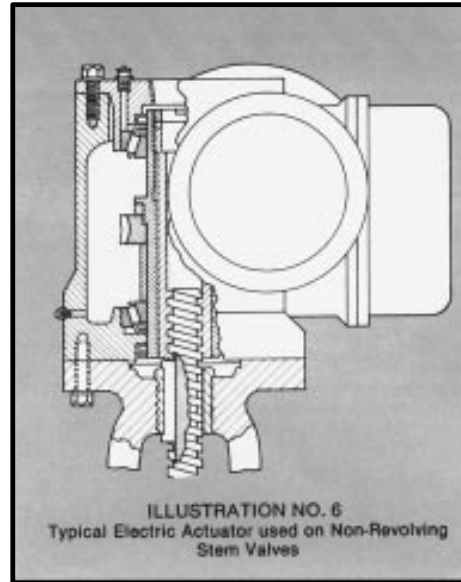
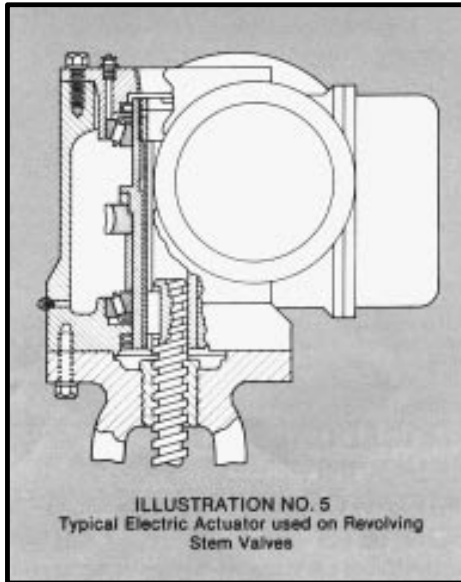

Torque Switch

The torque switch is set during factory assembly to seat the valve against the specified unbalanced pressure and to protect the valve from excessive seating forces. Should it become necessary to change the torque switch setting for any reason, the local Flowserve-Raleigh representative should be contacted for instructions.

Disassembly Procedures For Valve Parts Area 2

NOTE: For a definition of Area 2, see page 10.

NOTE: see Illustration No. 1, page 5, for an explanation of valve parts nomenclature.

Step-by-step disassembly procedures are described below. The procedures include disassembly instructions for stop, stopcheck (non-return), and piston lift check valves. The applicable instructions should be read thoroughly before the start of disassembly.

All of the following bonnet disassembly procedures are arranged in accordance with the general comments on page 10. Study these pages carefully before beginning.

Stop And Stop-Check (Non-Return) Valves

NOTE: See Illustration No. 1, page 5.

1. Loosen the packing gland bolt nuts and tap the gland which should relieve any pressure which might be trapped in the valve. This is important.
2. Carefully remove the bonnet stud nuts or cap screws.
3. Remove the packing gland bolts nuts.

4. Use a chain hoist in line with the stem to lift the stem-bonnet assembly out of the body. During this process, mark the body bonnet, and gasket at corresponding points (other than sealing surfaces) so that their relative position can be duplicated in reassembly. In laying the parts aside for inspection, it is imperative that they be placed carefully on a bed of rags or other soft material to avoid marring any machined surface, particularly any seating and sealing surfaces.
5. Unscrew the stem from the bonnet bushing.
6. On stop valves, the disk and disk-nut assembly is attached to the stem. On stop-check (non-return) valves, the piston disk assembly is not attached to the stem and must be removed separately. See Step 7.
7. Screw 3 / 8 – 16 UNC bolts (1 / 2 – 13 UNC on 12 " valve) into the threaded bosses or nuts provided in the piston. The piston now can be lifted from the valve. Occasionally, a vacuum may be formed by the cooling fluid in the pipe line below the valve. Until relieved, this vacuum will prevent removal of the piston.
8. The bonnet end opening should be kept covered whenever possible.

Piston Lift Check Valves

NOTE: See Illustration No. 7.

Piston lift check valves are constructed with valve bodies similar to the corresponding stop or stop-check (non-return type valves. Disassembly is simplified by the absence of a yoke and stem.

NOTE: Care must be taken in removing the cover bolting in case pressure should be trapped in the body (downstream piping). Check to make certain all downstream pressure is relieved.

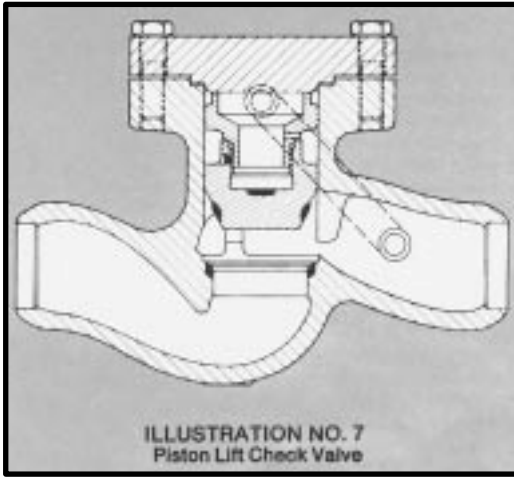

1. Carefully remove the cover nuts or cap screws observing the above caution.
2. Lift the cover off the valve. During the process, mark the body, cover and gasket at corresponding points (but not on the sealing surfaces) for reference and reassembly. In laying the parts aside for inspection, it is imperative that they be placed carefully on a bed of rags or other soft material to avoid marring any machined surface, particularly any seating and sealing surfaces.
3. Screw 3 / 8 – 16 UNC bolts (1 / 2 – 3 UNC on 12 " valve) into the threaded bosses or nuts provided in the piston. The piston now can be lifted from the valve. Occasionally, a vacuum may be formed by the cooling fluid in the pipe line below the valve. Until relieved, this vacuum will prevent removal of the piston.
4. The bonnet end opening should be kept covered when ever possible.

Reassembly Procedure For Bolted Bonnet Valves

Introduction

The reassembly procedures in this manual are not as detailed as the disassembly instructions since, in many cases, just a reverse procedure is used. However, step-by-step instructions are provided. In addition, the following general points should be considered.

1. The most important consideration in the reassembly of valves is cleanliness. All loose scale should be removed with a wire brush, emery cloth, or acid solvent. Oil and grease should be removed from all parts with a suitable solvent to prevent any foreign matter from collecting on sealing seating surfaces.
2. Unless it is impossible to do so, use a new gasket when reassembling a bonnet which has been disassembled whether it was leaking or not.
3. When reassembling valve bonnets, always examine stem packing and replace if necessary.

4. Observe all of the reference marks or prick punch marks assigned during disassembly so that the original part relationships can be maintained.

Stop And Stop-Check (Non-Return Valves)

NOTE: See Illustration No. 1, page 5.

1. Insert the disk, disk-nut, stem assembly, or the disk-piston and stem, lowering carefully until they rest on the valve seat. Hold the stem centrally in the valve bore.
2. Install a new gasket on the body.
3. Lower the bonnet into position, rotating the stem as necessary to engage the yoke bushing threads.
4. Install and tighten the bonnet stud nuts of cap screws in accordance with the torque values shown on page 4. All nuts or cap screws must be tightened uniformly in a star pattern to avoid cocking the bonnet.
5. Reassemble the actuator to the valve using a procedure opposite the disassembly.

Piston Lift Check Valves

NOTE: See Illustration No. 7.

1. Insert the disk-piston, lowering it carefully until it rests on the valve seat.
2. Install a new gasket on the body.
3. Lower the cover carefully onto the valve.
4. Install and tighten the cover stud nuts or cap screws in accordance with the torque values shown on page 4. All nuts or cap screws should be tightened uniformly in a star pattern to avoid cocking the cover.

Supplementary Repair Information

In analyzing valve trouble in the field, it is important to consider the following factors:

1. Size of the valve.
2. Figure number of the valve.
3. Lot number of the valve.
4. Service (water, oil, gas, super-heated steam, etc.).
5. Operating pressure and temperature.
6. Direction of flow through stop valves (inlet pressure above the disk or below the disk)
7. Rate of flow through the valve (lbs. per hour or gallons per minute).

8. At what pressure, temperature of flow rate does the reported trouble occur.
9. Pressure drop across the valve.

Information Request

If the maintenance problem looks particularly difficult, it is suggested that you contact your local Flowserve-Raleigh representative. He is familiar with these maintenance instructions and has a variety of engineering data sheets. In all communications with your local representative concerning difficulties, mention the valve size, figure number, lot number (if one is given) and as many of the nine conditions listed above as possible. Some of this information is found on the nameplate attached to the valve bonnet.

General Information

 **WARNING:** Edward valves are not provided with a pressure relief device. A pressure relief device must be provided elsewhere in the piping system to prevent the piping system pressure from exceeding the maximum rated pressure of the valve.

Welding Valves Into Piping

Welding is outside the scope of this manual, but Flowserve-Raleigh recommends you consult the appropriate welding procedure in

ASME/ ANSI B31, or whatever other codes apply to your system. When welding valves into piping, make sure there is no foreign material on the seat joint, then close the valve tightly to avoid distorting the seats.

During subsequent stress relief of the welds, leave the valve closed to avoid distorting the valve seat. Also, during stress relief, assure that the valve upperstructure is not overheated. After welding and stress relief, open the valve and flush the line to clean out all foreign matter.

Piping Support

Piping should be supported sufficiently to preclude excessive end loads on the valve.

Valve Installation Guidelines

Except as noted below, Edward stop valves can be installed in any position. Installed positions with the valve cover or bonnet below horizontal, where dirt and scale can accumulate in the valve neck, should be avoided. The orientation limits shown in Figures 1 and 2 must not be exceeded for Edward Stop-Check valves and Check valves. The limitations given for line inclination and bonnet roll angle should not be combined.

All Check and Stop-Check valves should be installed with 10 or more diameters of straight pipe upstream of the valve to minimize flow disturbances. For additional information, refer to the "Technical" section of the Flowserve, Forged Steel Catalog, Publication FCE-EVENCT0001 .

Notes On Valve Operation

Valves equipped with electric motor actuators have special tags attached which indicate the correct torque switch setting for the valve. Exceeding these torque switch settings can cause damage to the valve.

Never use an electric motor actuator to backseat a valve. This can result in damage to the valve stem and bonnet backseat.

Notes On Valve Maintenance

When replacing the bonnet gasket in Edward valves, follow the torque requirements on page 4 closely. Failure to torque the bonnet bolting properly will result in gasket failure. When replacing the valve stem packing, never machine the packing chamber oversize. This will result in blowout of the packing.

Lubrication

In order to obtain full service life, valves require periodic lubrication of the stem threads. Exposed threads should be wiped clean of old grease and accumulated dirt. Fresh lubricant should then be applied. This is most effectively done with the valve in the closed position. For valves that see frequent operation, such as motor actuated valves, the lubricant should be replenished every three months. If extreme service conditions dictate, a more frequent relube schedule is recommended. The recommended lubricant for all stem threads is Rykon

EP #2, manufactured by the American Oil Company. This is an extreme pressure, extreme temperature lubricant of high quality. For valves that are operated infrequently, relubrication should be at least once a year.

Seat And Disk Joint Leaks

A leak existing between the seat and disk of a closed valve might be indicated by one of the following: a definite pressure loss in the high-pressure side of the valve; continued flow through an inspection drain on the low pressure side; or, in hot water or steam lines, a downstream pipe that remains hot beyond the usual length of time and conductivity range. Such a leak may be the result of closing on dirt, scale or other foreign matter in the line. It may also develop because of the operator's failure to close the valve tightly. An increased velocity is imparted to a flow forced through a very small opening. This increased velocity subsequently gives rise to the "cutting" of both disk and seat, particularly by particles of line scale or rust in suspension or normal solids in solution. In spite of the fact that the hard surfaced material on the seat and disk is corrosion and erosion resistant, grooves, pit marks, or other surface irregularities may be formed on the seat and

disk joint surfaces when the disk is closed against a foreign body on the seat. This sometimes occurs during the initial start up of a piping system. Leakage of steam through a valve which is badly steam cut has a whistling or sonorous sound. If the valve is only slightly steam cut, however, leakage is identified by subdued gurgling or weakly popping sounds. These sounds can be heard through a stethoscope or by placing one end of a stick against the valve body while holding the other end between the teeth, with hands over the ears.

How To Order Parts

During normal working hours, call 800-225-6989 or 919-832-0525 . To assure the correct parts for your Univalve®, include the valve size, the figure number including any prefix and / or suffixes and if available, the B/ M number. All nuclear valves require the B/ M number to properly identify your Flowserve Valve. This information is located on the valve nameplate. The nameplate is attached to a yoke leg via a cable. If the nameplate is inaccessible, you can use your Flowserve sales drawing; please include the drawing number as well.

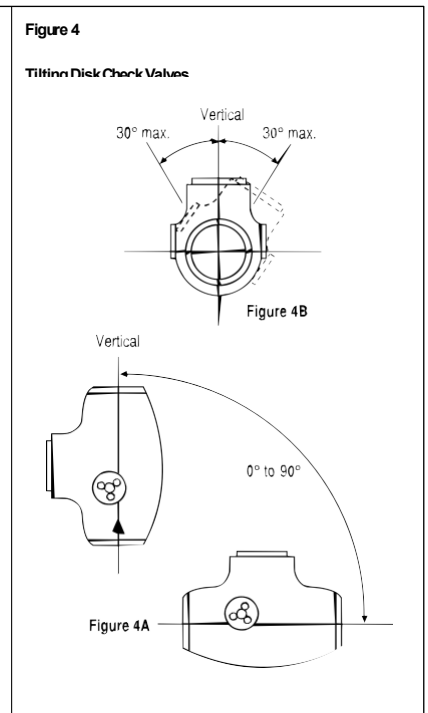
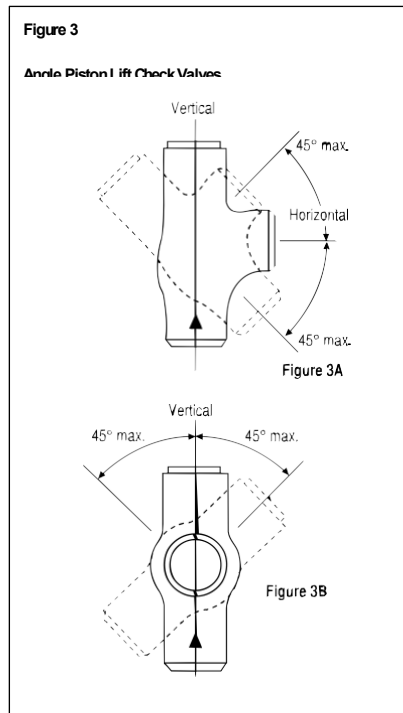
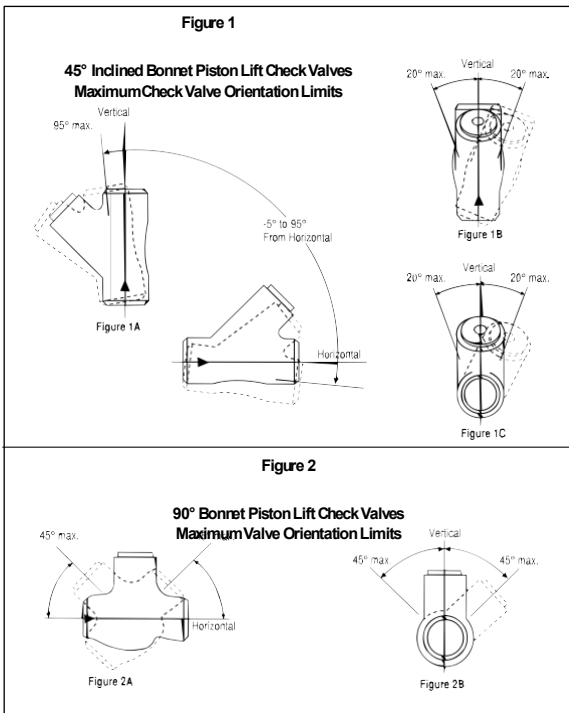



Flowserve Flow Control Division
Edward Valves
1900 South Saunders Street
Raleigh, NC 27603
USA

FCD EVENIM2004-03-AQ 10/15 Printed in USA. (Replaces V-380 R2)

To find your local Flowserve representative
or for more information about Flowserve Corporation, visit
www.flowserve.com.

Flowserve Corporation has established industry leadership in the design and manufacture of its products. When properly selected, this Flowserve product is designed to perform its intended function safely during its useful life. However, the purchaser or user of Flowserve products should be aware that Flowserve products might be used in numerous applications under a wide variety of industrial service conditions. Although Flowserve can (and often does) provide general guidelines, it cannot provide specific data and warnings for all possible applications. The purchaser/user must therefore assume the ultimate responsibility for the proper sizing and selection, installation, operation, and maintenance of Flowserve products. The purchaser/user should read and understand the Installation Operation Maintenance (IOM) instructions included with the product, and train its employees and contractors in the safe use of Flowserve products in connection with the specific application.

While the information and specifications contained in this literature are believed to be accurate, they are supplied for informative purposes only and should not be considered certified or as a guarantee of satisfactory results by reliance thereon. Nothing contained herein is to be construed as a warranty or guarantee, express or implied, regarding any matter with respect to this product. Because Flowserve is continually improving and upgrading its product design, the specifications, dimensions and information contained herein are subject to change without notice. Should any question arise concerning these provisions, the purchaser/user should contact Flowserve Corporation at any one of its worldwide operations or offices.

© 2015 Flowserve Corporation, Irving, Texas, USA. Flowserve is a registered trademark of Flowserve Corporation.