



MN
***Solids Handling
Pumps***



Pump Supplier To The World

Flowserve is the driving force in the global industrial pump marketplace. No other pump company in the world has the depth or breadth of expertise in the successful application of pre-engineered, engineered, and special purpose pumps and systems.

Pumping Solutions

Flowserve is providing pumping solutions that permit customers to continuously improve productivity, profitability and pumping system reliability.

Market-Focused Customer Support

Product and industry specialists develop effective proposals and solutions directed toward market and customer preferences. They offer technical advice and assistance throughout each stage of the product life cycle, beginning with the inquiry.



Dynamic Technologies

Flowserve is without peer in the development and application of pump technology, including:

- Hydraulic engineering
- Mechanical design
- Materials science
- Intelligent pumping
- Manufacturing technology

Broad Product Lines

Flowserve offers a wide range of complementary pump types, from pre-engineered process pumps, to highly engineered and special purpose pumps and systems. Pumps are built to recognized global standards and customer specifications.

Pump designs include:

- Single-stage process
- Between bearing single-stage
- Between bearing multistage
- Vertical
- Submersible motor
- Positive displacement
- Nuclear
- Specialty

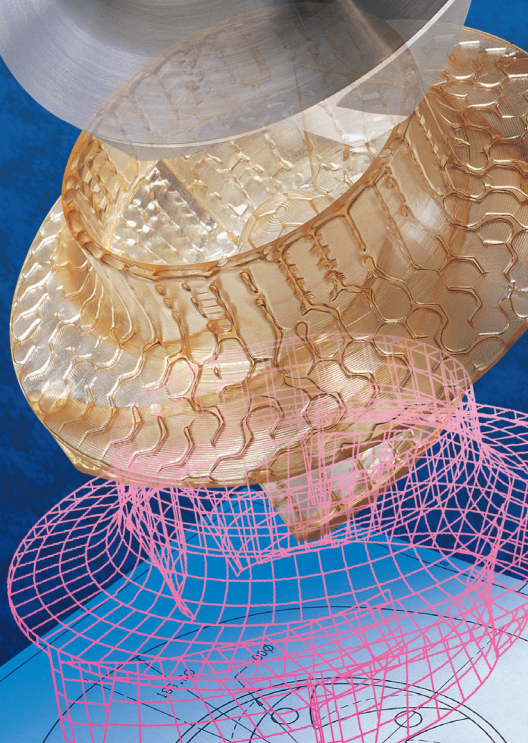
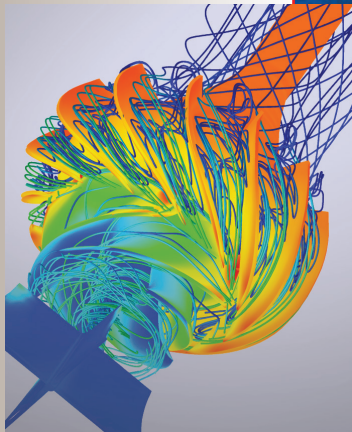
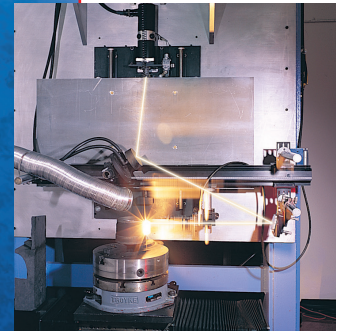
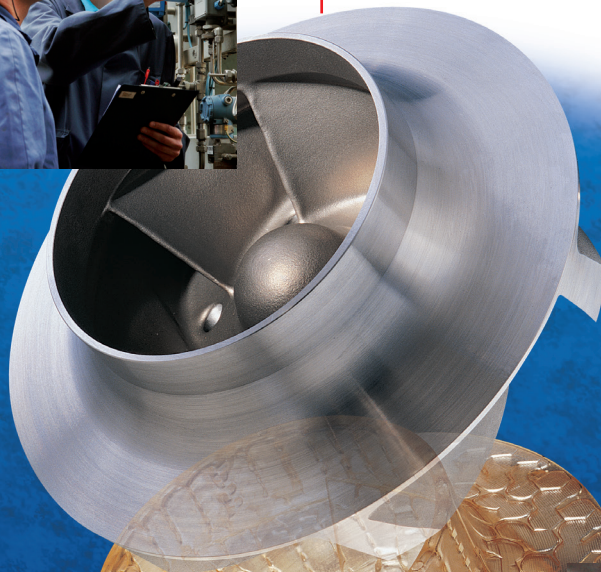

MN
Solids Handling Pumps

Rugged and Efficient Design
The Flowserve MN is an end suction, side discharge, mixed-flow, non-clog pump. It is specifically engineered for reliability, low cost and long life in demanding sewage handling services or where solids in suspension are of particular concern. The heavy-duty MN is designed, manufactured and tested in conformance with the Standards of the Hydraulic Institute.

- Performance Benefits**
- Flexibility
 - Configurations
 - Motor mounts
 - Nozzle orientation
 - Reliability
 - Robust construction
 - Special materials
 - Efficiency
 - Broad hydraulic range
 - Reduced power consumption
 - Easy maintenance

- Typical Application**
- Sewage
 - Storm water
 - Industrial wastes
 - Dry dock
- Complementary Pump Designs**
Depending upon application requirements, Flowserve can also provide these pump designs:
- Dry-pit, solids handling
 - Vertical, wet-pit
 - Submersible non-clog

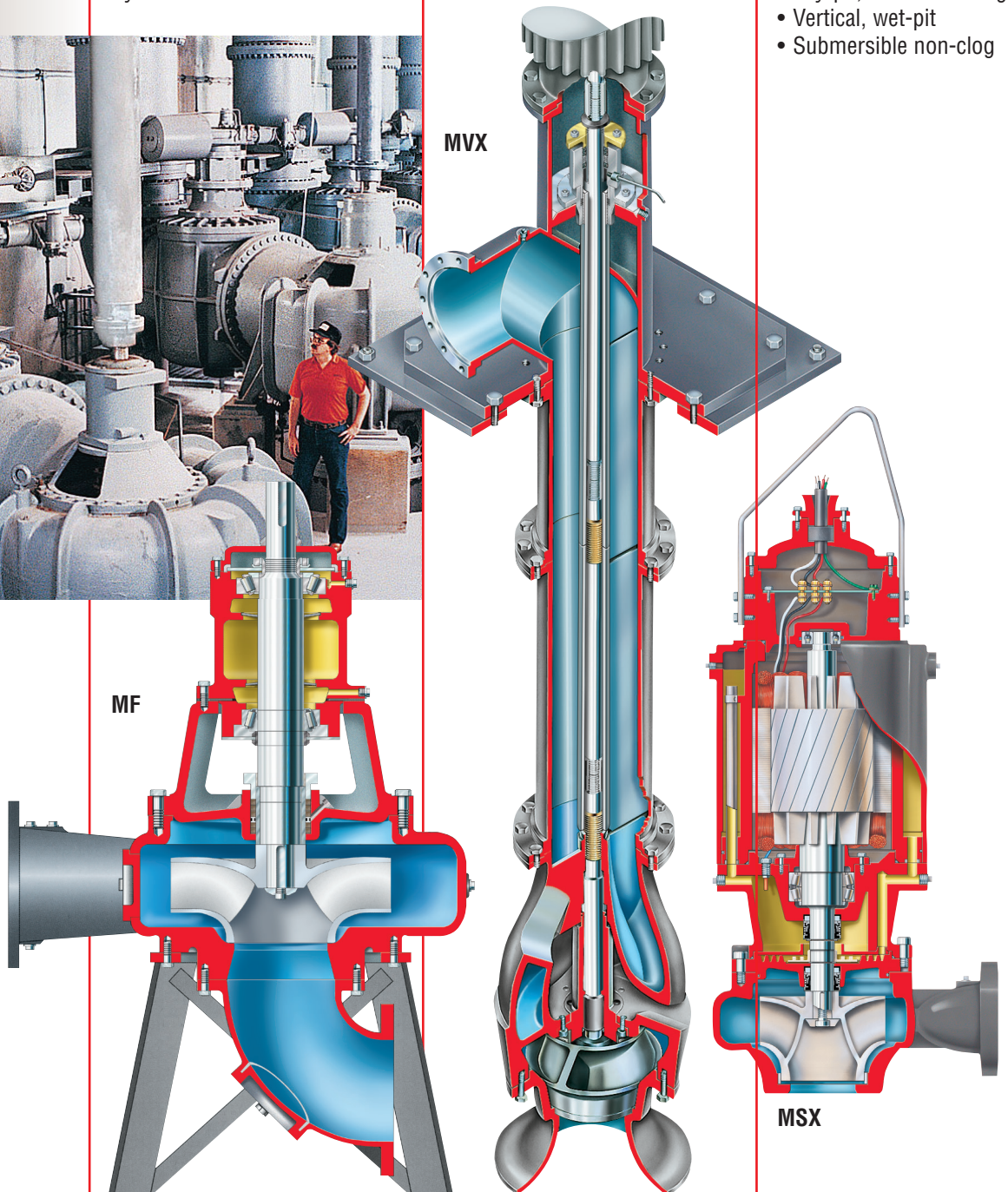
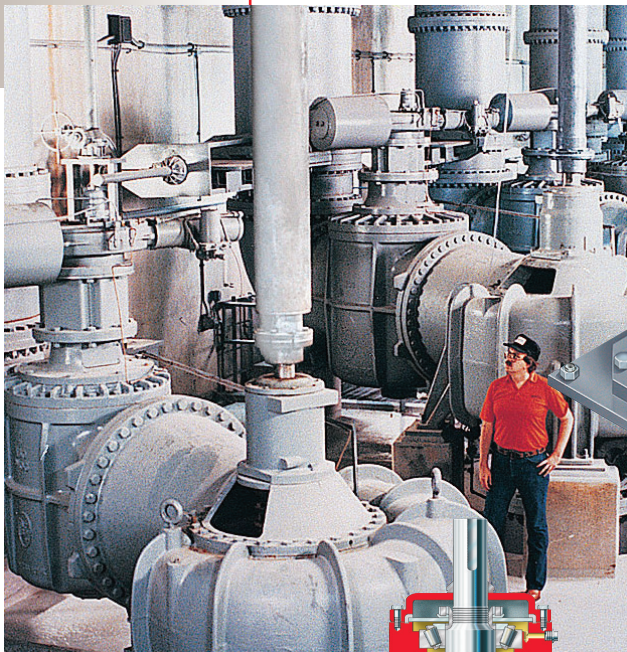

MN
Solids Handling
Pumps

Renowned for reliability, the rugged Flowserve MN solids handling pump offers extraordinary flexibility and cost efficiency. Versatile performers, large-capacity MN pumps can be found throughout the collection-treatment-effluent municipal cycle, in industrial waste service and dry dock applications.

Operating Parameters

- Flows to 45 500 m³/h (200 000 gpm)
- Heads to 90 m (300 ft)
- Sizes to 1800 mm (72 in)

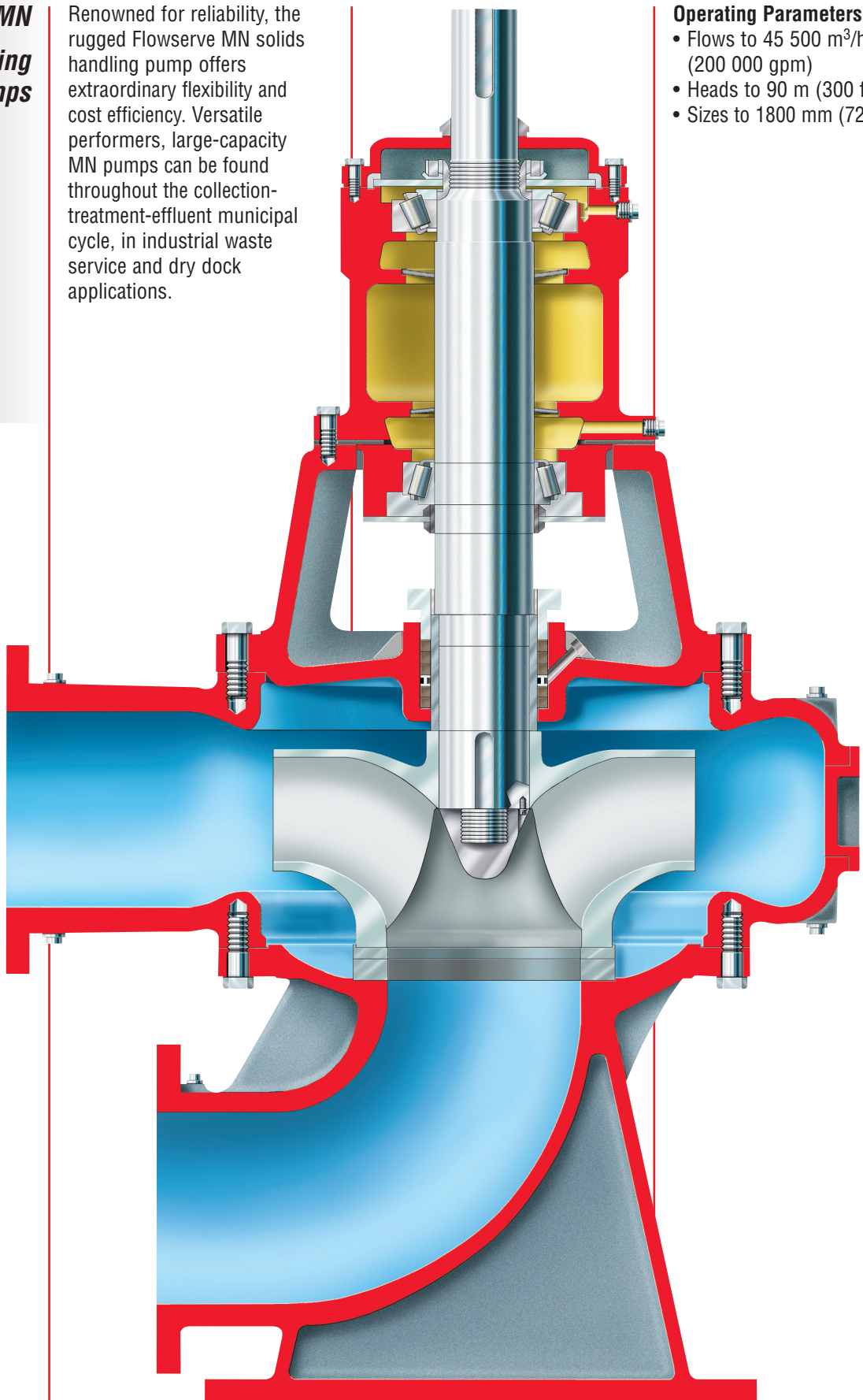

Carbon Steel Shaft with oversized dimensions is robust and rigid, significantly extending shaft and packing or seal life.

Replaceable Shaft Sleeve, made of stainless steel, is keyed to the shaft and sealed to prevent leakage between the shaft and sleeve. Protects more expensive shaft from wear and corrosion.

Robust Construction with all wetted parts made of ASTM A278 CL30 cast iron. Suction and discharge nozzles are rated to ASME Class 125.

Casing is one-piece volute type with back pullout design and handhole to facilitate maintenance.

Separate Suction Head/Elbow features adjustable, double chrome steel wear ring to maintain dimensional integrity and efficiency. Handhole access for inspection and cleaning is standard.

Non-clog Impeller is secured with a locking nut to prevent loosening by torque from forward or reverse rotation. Chrome steel wear ring is standard.

Stuffing Box readily accommodates packing or mechanical seals per customer preference.

Opposed Tapered Roller Bearings (grease lubricated) firmly support the shaft, virtually eliminate axial and radial thrust loads, and are designed for a minimum of 100 000 hours of B10 life.

Bearing Housing With Integral Jacking Bolts permits axial adjustment of wear rings via a shim pack between the bearing housing and back head.

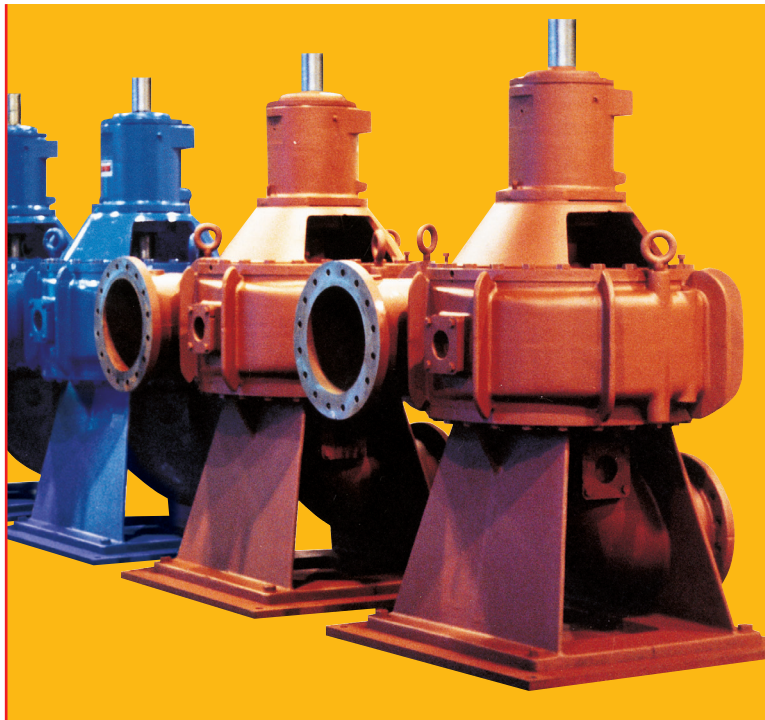

Design Features

Flexibility

- Horizontal and vertical models
- Variety of mounting arrangements
- Variety of nozzle positions to suit most piping arrangements without special or costly modifications
- Direct or independent motor mounting

Reliability

- Minimal shaft deflection with oversized shaft and reduced overhang virtually eliminating shaft failure and increasing packing or seal life
- Conservative bearing design arranged to eliminate all radial and axial play
- Replaceable hardened chrome steel wear rings on impeller and suction head to extend pump life
- Hardened chrome steel shaft sleeve standard
- Supports to minimize vibration and assure rigidity

Efficiency

- Maximum solids handling capabilities
- Wide range of efficient operation and reduced power consumption
- Adjustable wear ring clearance for continued high efficiency

Ease of Maintenance

- Easy access to stuffing box through large openings in the bearing housing support
- Removable gland for easy packing adjustment or replacement
- Stuffing box arranged for either grease or water seal
- Wide variety of mechanical seal options
- Back pullout of entire rotating assembly without disturbing the casing or suction and discharge piping
- Readily accessible lubrication points in bearing housing

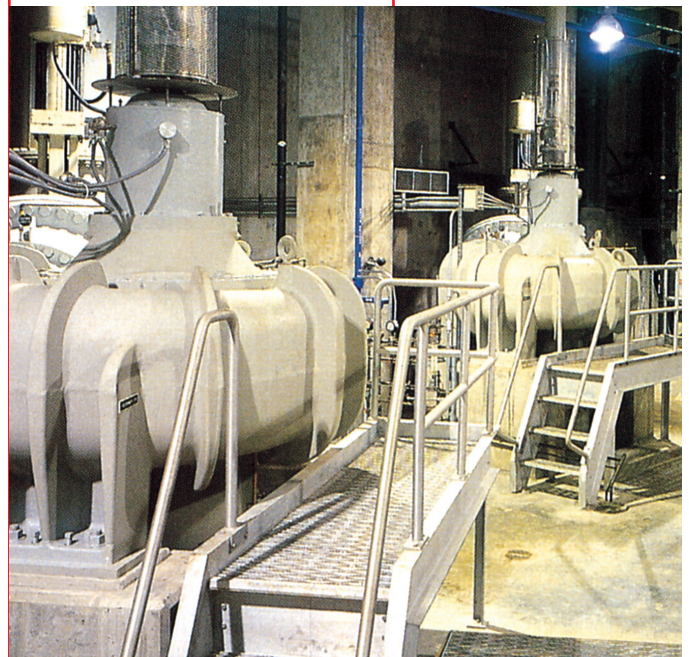

Technical Data and Options

Available Options

- Extra hard chrome steel wear rings
- 316 SS or hardened shaft sleeves
- Single, double, cartridge or split mechanical seals
- Bronze, nickel, cast iron or stainless steel castings
- Paint systems
- Baseplates
- Testing
 - Performance
 - Hydrostatic
 - Variable speed
- Coupling type
- Coupling guard

Materials of Construction

Part	Standard Fitted	Optional Material
Casing	Cast Iron	1.5% Ni Cast Iron Ductile Iron
Impeller	Cast Iron	1.5% Ni Cast Iron Bronze 11–14% Chr. Stl.
Impeller Wearing Ring	11–14% Chr. Stl. 250–300 BHN	325–350 BHN
Casing Wearing Ring	15–18% Chr. Stl. 300–350 BHN	400–450 BHN
Gland	Bronze	—
Shaft	Carbon Steel	Low Alloy Steel
Shaft Sleeve	11–14% Chr. Stl. 325–400 BHN	450–500 BHN
Line Bearing	Tapered Roller	—
Thrust Bearing	Tapered Roller	—
Stuffing Box Head	Cast Iron	1.5% Ni Cast Iron Ductile Iron
Suction Head or Elbow	Cast Iron	1.5% Ni Cast Iron Ductile Iron
Seal Cage	PTFE	Bronze
Packing	Non-Asbestos	Mechanical Seals
Adjusting Shims	Plastic	—
Grease Fittings	Alemite	—
Coupling	All Metal Flexible	Refer to Factory
Horizontal Baseplates	Fabricated Steel	—
Vertical Motor Pedestal	Fabricated Steel	—

Configurations

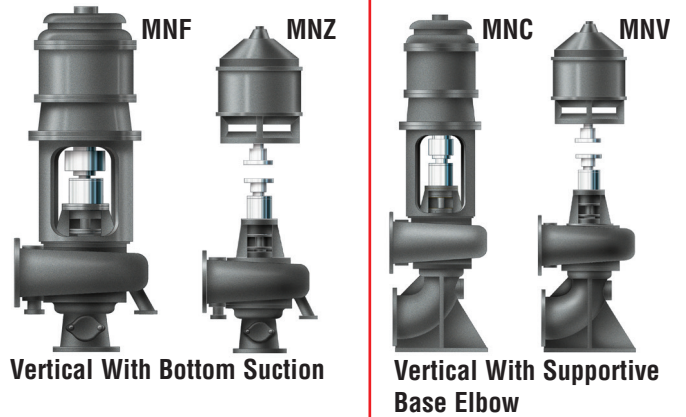
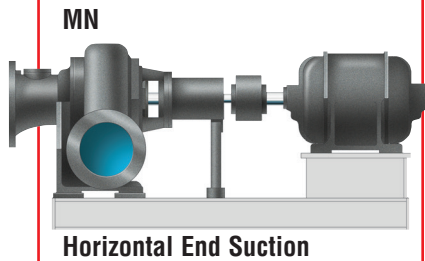

MN Range Chart

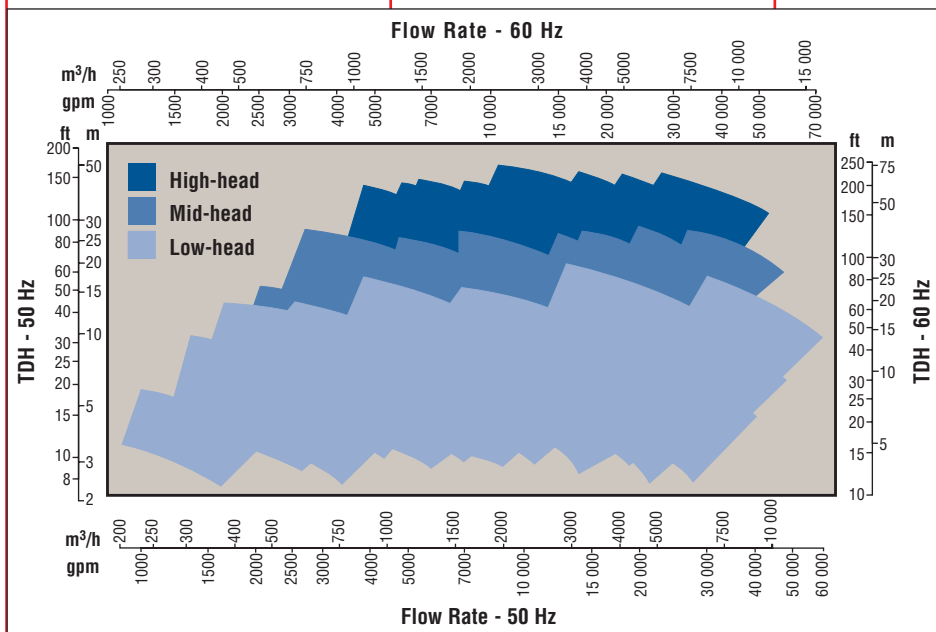

Global Engineered Services and Support

- Total Cost Reduction*
- Asset Management*
- Product Life Cycle*
- Performance Re-rates*
- Site Diagnostics*
- Repair Services*
- Energy Management*
- Spare Parts*
- Maintenance Contracts*
- Materials Upgrades*
- Turnkey Services*
- Field Repairs*
- Installation*
- Project Supervision*
- Commissioning*
- Equipment Upgrades*
- Condition Monitoring*
- Systems Analysis*
- Field Machining*

Service Dedication

Flowserve Engineered Services is focused on providing customers with uncompromising service and support, where and when needed. Engineered Services is dedicated to delivering the highest quality support by integrating its extensive pump and materials engineering knowledge with creative service solutions. Engineered Services prides itself in understanding the business challenges facing customers and is prepared to manage solutions to succeed as a team.

A worldwide network of service and repair centers staffed by highly skilled engineers and technicians is available around the clock, seven days a week to respond to customer queries, evaluate and troubleshoot problems and provide reliable solutions.



Strength of Experience, Commitment to Excellence

Flowserve has long served industries requiring superior equipment performance and service life.

- Oil and gas production
- Hydrocarbon processing
- Chemical processing
- Water resources
- Power generation
- Nuclear
- Mining and mineral processing
- Pulp and paper
- General industry

Engineered Services is dedicated to maximizing equipment performance and providing reliability-centered maintenance programs for pumps and related equipment, regardless of manufacturer. Using the FlowStar™ asset management software, Engineered Services tracks performance and supports improvement programs using a service life cycle cost business approach. The results are improved reliability and increased profitability.

Your Business Partner

Flowserve partners with customers to respond to the dynamic business conditions that affect them. Flowserve will work with customers to drive efficiency, maximize throughput and control process quality. Whether your needs involve on-site technical assistance or broader project planning with full turnkey responsibility, you can rely on the strength of Flowserve Engineered Services to deliver professional, reliable results.



Low Frequency Pressure Pulsations

50% Flow

Pressure Amplitude

NPSH $\frac{U_0^2}{2g}$

Frequency

10.0
5.0
1.0

10
20
30
40
60
90
110

0.9
0.8
0.7
0.6
0.5
0.4
0.3

**Flowserve... Supporting Our Customers
With The World's Leading
Pump Brands**



Cameron™

Pleuger®

Durco®

Niigata Worthington™

Scienco™

TKL™

IDP®

Pacific®

HALBERG™

Worthington Simpson™

Calder™ Energy Recovery Devices

Flowserve®

Byron Jackson®

SIHI®

Lawrence Pumps®

Worthington®

Sier-Bath®

United Centrifugal®

Western Land Roller™

INNOMAG®

Wilson-Snyder®

Aldrich™

ACEC™

USA and Canada

Flowserve Corporation
5215 North O'Connor Blvd.
Suite 2300
Irving, Texas 75039-5421 USA
Telephone: +1 937 890 5839

Europe, Middle East, Africa

Flowserve Corporation
Parallelweg 13
4878 AH Etten-Leur
The Netherlands
Telephone: +31 76 502 8100



Your local Flowserve representative:

**To find your local Flowserve representative,
please use the Sales Support Locator System
found at www.flowserve.com
or call: +1 937 890 5839.**

Latin America

Flowserve Corporation
Martín Rodríguez 4460
B1644CGN-Victoria-San Fernando
Buenos Aires, Argentina
Telephone: +54 11 4006 8700
Telefax: +54 11 4714 1610

Asia Pacific

Flowserve Pte. Ltd.
10 Tuas Loop
Singapore 637345
Telephone: +65 6771 0600
Telefax: +65 6862 2329