

# Pulp and Paper

*Pulp Production*

*Chemical Recovery*

*Paper Stock Preparation*

*Paper Manufacturing*

*Mill and Environmental  
Services*



**FLowsERVE**



## ***Pump Supplier To The World***

*Flowserve is the driving force in the global industrial pump marketplace. No other pump company in the world has the depth or breadth of expertise in the successful application of pre-engineered, engineered, and special purpose pumps and systems.*

## ***Supplier of Choice to the Pulp and Paper Industry***

As one of the world's largest users of water, pulp and chemicals – for digestion, stock preparation, washing, bleaching, chemical recovery and recycling, and environmental control – the pulp and paper industry requires pumps of virtually every size and type for successful operation. As a leader in pump research and development, Flowserve offers a broad range of pump designs and industry experience to address the needs of the pulp and paper industry.

## ***Heritage Names of Distinction***

*ACEC™ Centrifugal Pumps*

*Aldrich™ Pumps*

*Byron Jackson® Pumps*

*Calder™ Energy Recovery Devices*

*Cameron™ Pumps*

*Durco® Process Pumps*

*Flowserve® Pumps*

*IDP® Pumps*

*Niigata Worthington™ Pumps*

*Pacific® Pumps*

*Pleuger® Pumps*

*Scienco™ Pumps*

*Sier-Bath® Rotary Pumps*

*TKL™ Pumps*

*United Centrifugal® Pumps*

*Western Land Roller™ Irrigation Pumps*

*Wilson-Snyder® Pumps*

*Worthington® Pumps*

*Worthington Simpson™ Pumps*

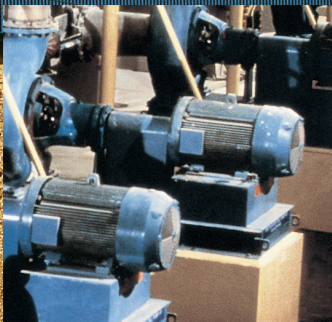

### ***Pump Designs***

Flowserve offers a wide range of complementary pump types, built to recognized global standards and customer specifications. These include:

- Single-stage process
- Between bearing single-stage
- Between bearing multistage
- Vertical
- Submersible motor
- Positive displacement
- Nuclear
- Specialty

### ***Available Configurations***

- Sealed and sealless
- Axially and radially split
- Volute and diffuser
- Close coupled and spacer coupled
- Single and double casing

### ***Dynamic Technologies***

Few, if any, pump companies can match the capabilities in hydraulic and mechanical design or in materials engineering that Flowserve possesses. Among these capabilities are:

- Computational fluid dynamics
- Flow visualization
- Cavitation studies
- Efficiency optimization
- Finite element analysis
- Rapid prototyping
- Captive alloy foundries
- Non-metallic materials processing and manufacturing

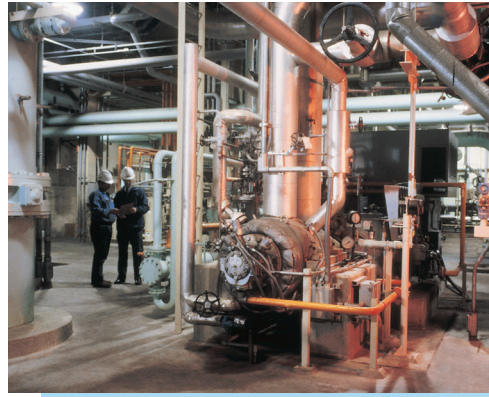

### ***Market-Focused Customer Support***

Product and industry specialists develop effective proposals and solutions directed toward market and customer preferences. They offer technical advice and assistance throughout each stage of the product life cycle, beginning with the inquiry. This provides the following benefits:

- Advanced technology solutions
  - Order engineering
  - Hydraulic engineering
- Broad product reliability
- Worldwide service and support
- Competitive price and delivery
- Technology innovation
- Applications expertise

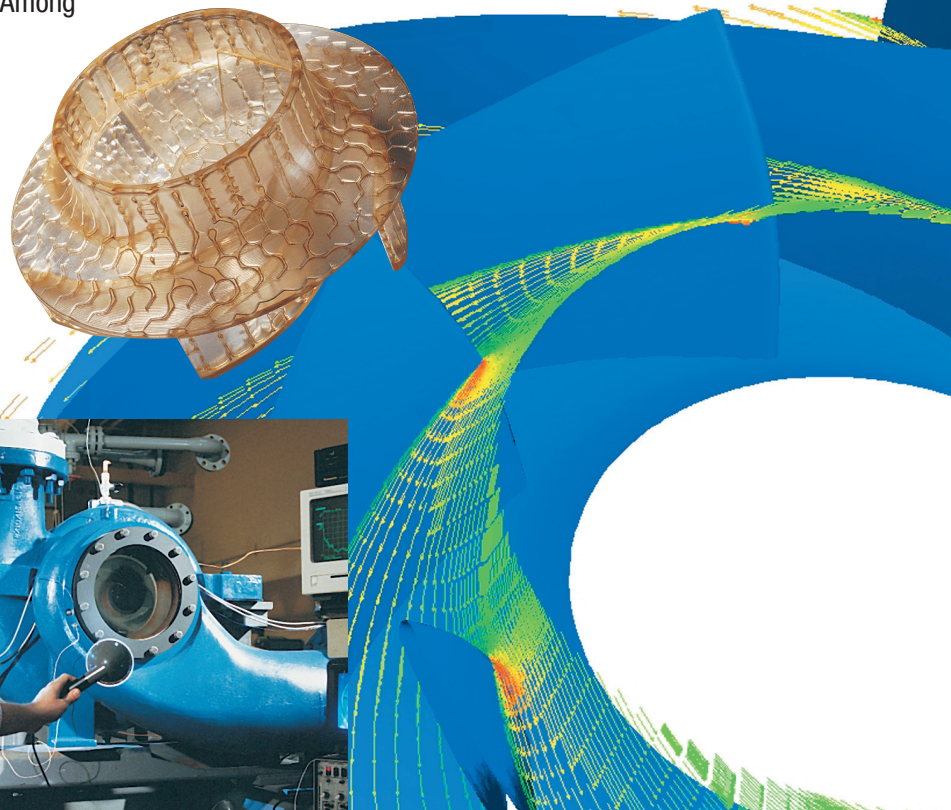
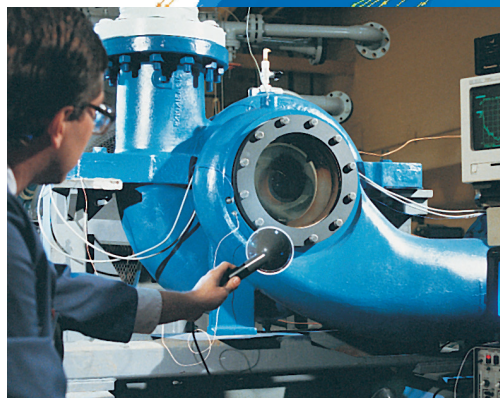

***The Pulp and  
Paper Industry –  
Flowserve Interface***

While facing many of the same business challenges as other global industries, the pulp and paper industry is focused on process refinements that enhance productivity, increase energy efficiency and protect the environment. Whether using the kraft or the sulfite method, oxygen or chlorine bleaching, virgin stock or secondary fibers, Flowserve can fully meet the liquid movement needs of the pulp and paper industry.



### **Materials Expertise**

Flowserve offers its customers an extensive range of corrosion-resistant materials – both metallic and non-metallic – along with the materials application expertise to provide the most cost-effective solutions for the very difficult services found in the pulp and paper industry.

In the forefront of materials engineering, Flowserve has developed numerous alloys, including: Alloy 20 (CN7M), a highly corrosion-resistant, austenitic stainless steel; X-Cavalloy, a proprietary cavitation-resistant material; Durcomet 100 (CD4MCuN), the first duplex stainless steel; and DC8, a proprietary cobalt-based alloy. Flowserve also designed the industry's first epoxy pump and the first fully PTFE-lined pump.

### **Engineering Design**

Flowserve pumps are renowned for their reliability with minimal total life cycle cost. They are versatile and adaptable to virtually any service due to the extraordinary combination of materials and configurations. Flowserve has more than 100 distinct models handling everything from paper stock and water service, chemical process and abrasive slurries, and power plant and effluent control applications. Flowserve has earned an unequalled reputation for innovative pump technology.

### **Application Know-How**

Flowserve sales engineers are highly regarded for their knowledge and skill in helping customers solve difficult process problems. Supporting their efforts is a staff of professionally qualified materials, product and applications engineers who can provide detailed technical assistance when needed. They can also assist customers with maintenance advice as well as spare parts recommendations and inventory analysis, too.

### **Leading the Pump Industry**

*As the global leader in pump design and engineering for the chemical processing industry, Flowserve plays a major role in the practical implementation of new and improved process technologies. Flowserve accomplishes this through a continuous commitment to research and technology and by its leadership in these important industry organizations and committees:*

*TAPPI • API • ASME • ASTM • Europump • HI • ISO • NACE • NFPA*

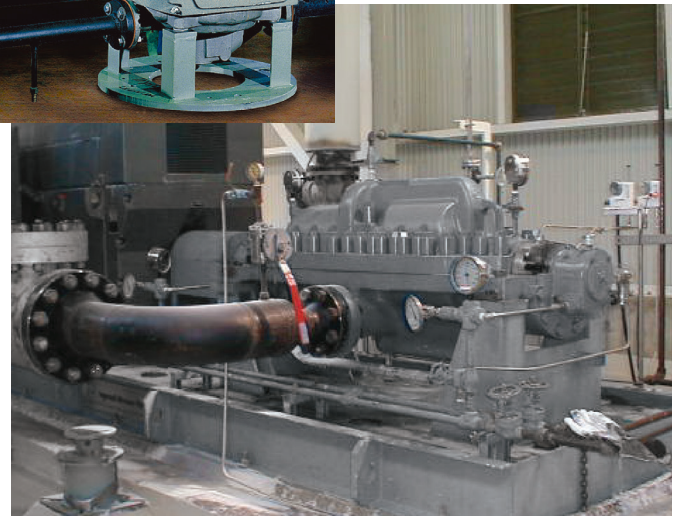
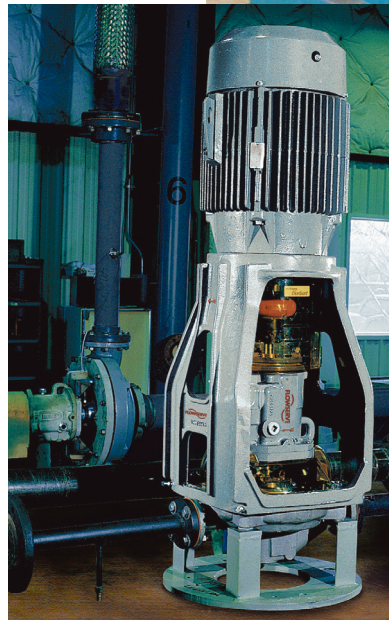
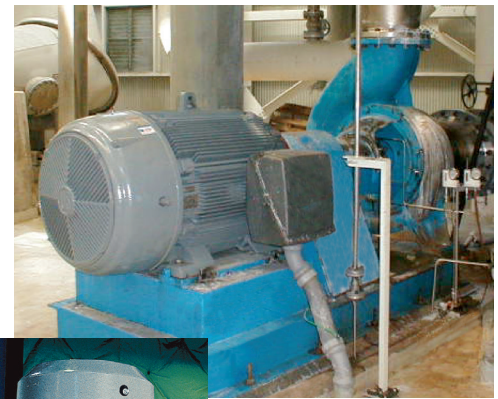

## *Pulp Production*

Due to the pervasive use of chemicals in pulp production, corrosion- and erosion-resistant pumps are critical to the pulp and paper industry. Steeped in pump research and materials development, Flowserve offers unrivaled materials, product and application knowledge.

From the digester to the washers to the causticizers, Flowserve offers corrosion- and erosion-resistant designs to extend equipment life and increase process efficiencies.



### ***Debarking***

Flowserve segmental ring pumps produce the high-pressure water used in debarking. Flowserve also offers recessed impeller sump pumps, slurry pumps and submersible pumps suitable for handling the large bark pieces found in this service.

### ***Pulping***

Whether using chemical, mechanical, or hybrid pulping methods, pumping cooked pulp requires abrasion and sometimes corrosion-resistant pumps, able to handle up to 70% solids content. Flowserve heavy-duty paper stock and hard metal slurry pumps provide the necessary toughness and versatility for this demanding application. Flowserve also offers a variety of ASME (ANSI) and ISO process pumps with semi-open, recessed impellers that are ideal for liquor transfer. Stainless steel, centerline API-type pumps are excellent for digester recirculation.

Flowserve pumps can be used with equal reliability in these demanding pulping processes:

- Defibering
- Deknotting
- Blending
- Auxiliary services

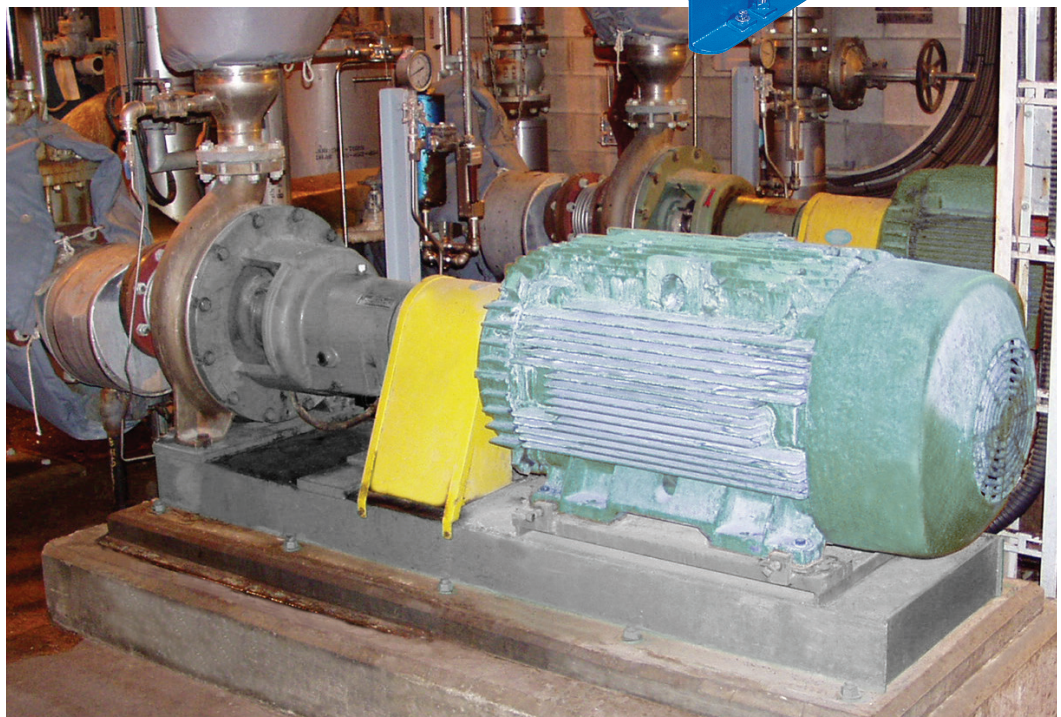
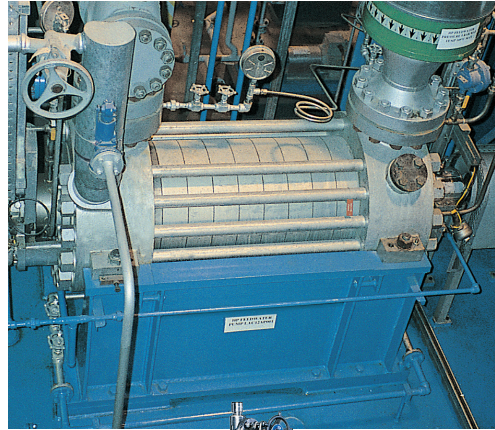

## *Chemical Recovery*

Chemical recovery is the heart of the modern pulp mill. The recovery and reconstitution of black and green liquors and the energy provided by burning the organic by-products are critical to reducing the mill's operating costs. These processes require reliable equipment that is both corrosion- and erosion-resistant. Flowserve pumps provide the required material compatibility and design flexibility.

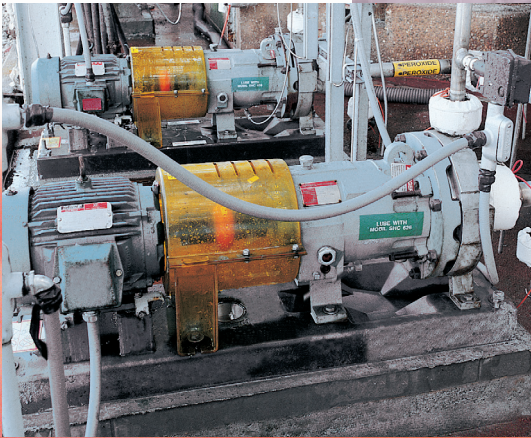



### ***Washing***

Brown stock washing has a significant impact on the cost effectiveness of the pulp mill by reducing the chemical requirements for bleaching while increasing chemical recovery. In addition to its performance-proven paper stock pump, Flowserve offers centerline and foot-mounted wash cycle pumps.

Flowserve also has two-screw pumps and axially split pumps capable of handling the higher efficiency, medium-consistency wash cycles adopted by some operations.

### ***Black Liquor***

Extracted during the washing cycle, black liquor has a significant economic impact on a paper mill's cost efficiency, as it can be used as a fuel source when concentrated to 65% solids or greater. Flowserve makes several evaporator service pumps to both ASME (ANSI) and ISO standards. These pumps may be specified with inducers for low NPSHA applications.

### ***Recausticizing***

Converting black and green liquors into white liquor suitable for use in the digesters is critical to the economic viability of a mill. Flowserve offers a variety of pumps for these services:

- White and green liquor transfer
  - Stock pumps, foot-mounted and centerline mounted chemical process pumps made from erosion- and corrosion-resistant materials such as duplex stainless steels and Worthite™
- Lime slaking
  - Horizontal or vertical hard metal abrasive slurry pumps

### ***By-Product Recovery***

Whether sold to market or used as fuel feed stocks, turpentine and tall oil provide economic benefit to kraft mills. Flowserve offers a variety of pumps for these applications.

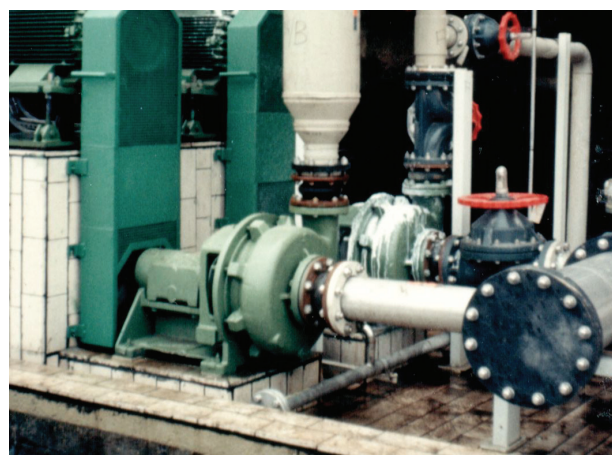
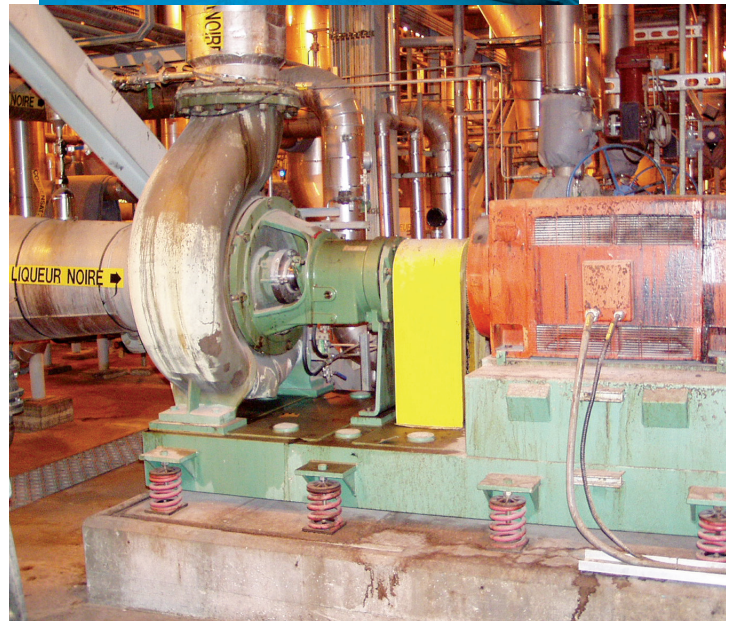
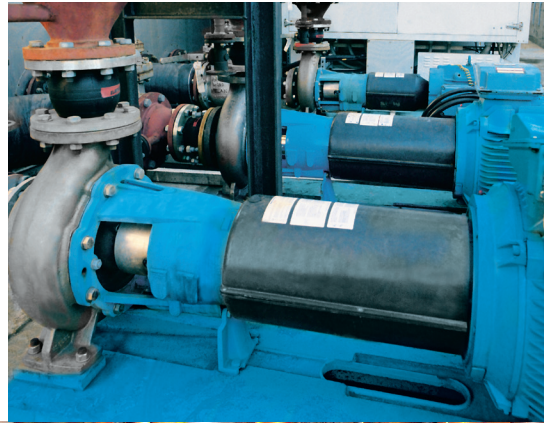

## *Paper Stock Preparation*

Whether using virgin pulp, broke or secondary fibers, preparing the fibrous raw materials for papermaking requires mechanical treatments such as refining. Imparting specific characteristics to the paper also requires the addition of many non-fibrous components such as mineral and chemical agents. To accomplish this, pulp and paper mills need reliable pumps that are resistant to corrosion and erosion. Flowserve is a leader in the development of corrosion- and erosion-resistant materials and reliability-enhancing pump features.

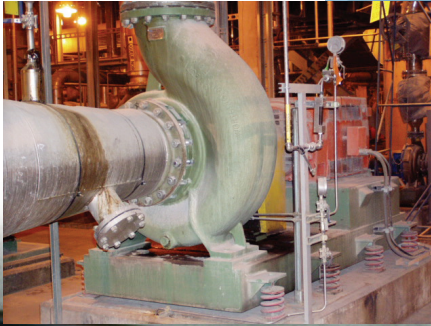

### ***Repulping***

Repulping dry fibers is abrasive and requires a steady and reliable stream of fresh and reclaimed water. Flowserve gives users the most flexibility in pump type and size, ensuring optimum operating efficiencies.

### ***Flotation Deinking***

The detergents, dispersants and foaming agents used in deinking can be erosive and corrosive. Additionally, deinking services typically contain high percentages of entrained air, which can reduce pump efficiency. The diverse range of products manufactured by Flowserve, including horizontal and vertical centrifugal pumps, affords users the flexibility to specify pumps to meet the requirements of each application.

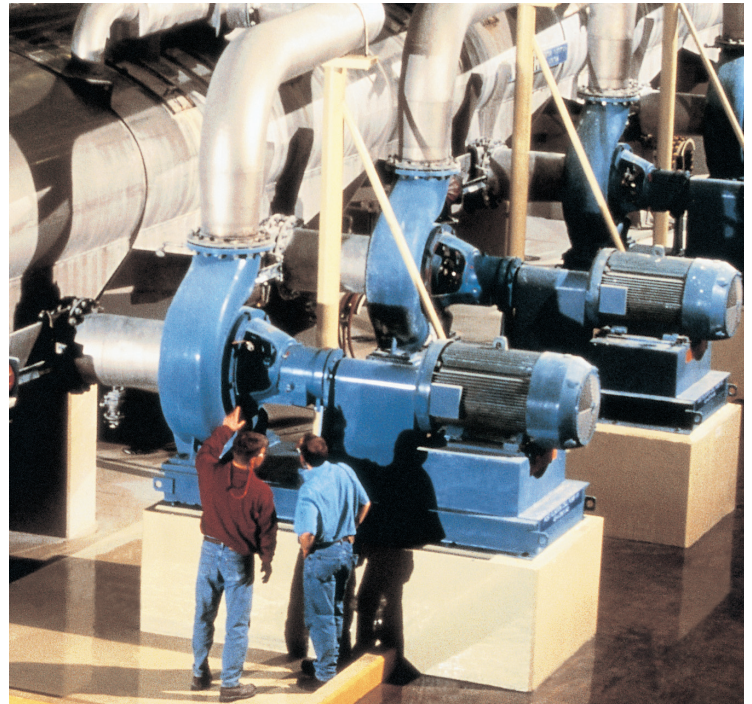

### ***Brightening and Bleaching***

The chemicals used to brighten and bleach pulp require pumps that can withstand both the corrosive and erosive nature of the process. Whether employing peroxide and oxygen or chlorine-based whitening techniques, Flowserve offers paper stock, twin screw and chemical process pumps in a multitude of materials to suit the application.

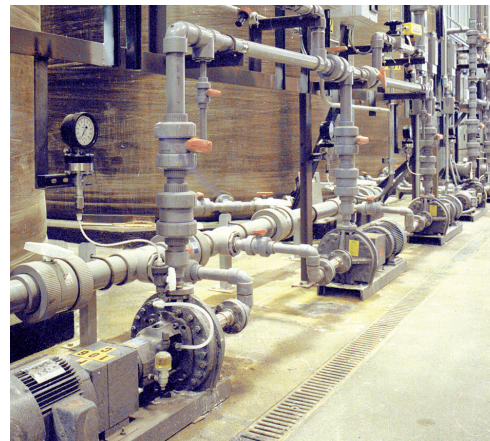

### ***Refining***

Refining requires a range of pump types, from feed water to slurry transfer. Flowserve offers several proven pump models in both vertical and horizontal designs to meet application needs.

### ***Additives***

Pigments, fillers, binders, preservatives and other chemicals are added to the paper stock to impart specific characteristics to the finished paper. Flowserve single-stage centrifugal pumps are ideal for this application.

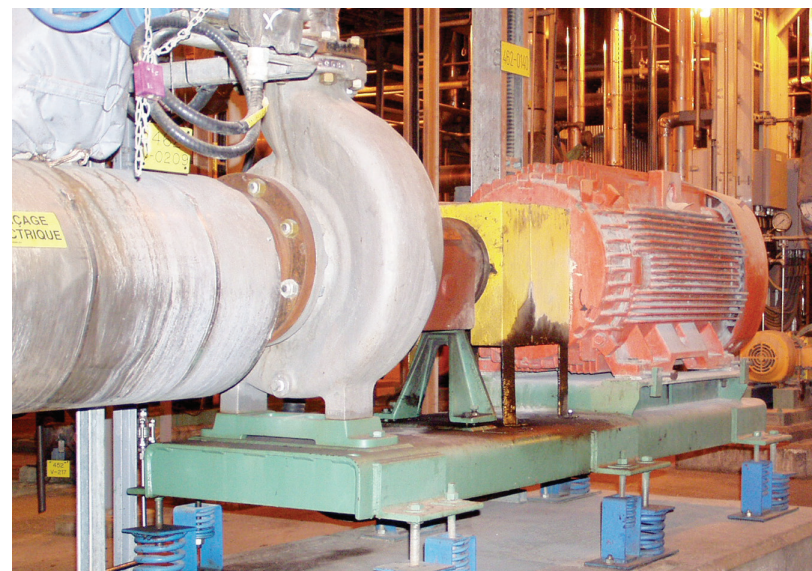

## *Paper Manufacturing*

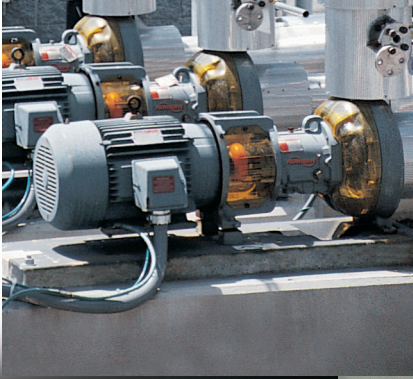

The approach system is the heart of the paper manufacturing process. It is in this multi-pump loop that paper stock is converted into paper. In addition to producing paper, this system must accomplish multiple functions critical to the operational efficiency and cost-effectiveness of the paper mill. These functions include fiber recovery, fresh water management and energy conservation. Flowserve manufactures pumps to address all these needs.



### ***Versatility, Durability, Reliability***

Regardless of the grade of paper stock or the size of the operation, Flowserve offers the pumps needed in the approach system to effectively perform the following:

- Stock circulation
  - Vertical and horizontal heavy-duty paper stock pumps; centerline-mounted pumps; and metallic or non-metallic chemical process pumps
- Stock feed
  - Heavy-duty paper stock pumps; one- and two-stage, low-pulse, high-efficiency pumps suitable for today's high-speed paper machines
- Fresh and process water supply
  - Vertical and horizontal axially split, single- and double-suction pumps to handle a wide range of flows and pressures
- White water
  - Heavy-duty paper stock pumps; centerline-mounted pumps; and metallic or non-metallic centrifugal process pumps
- Shower water
  - Heavy-duty paper stock pumps; ring section pumps; and axially split pumps for high-pressure shower pumps
- Surface treatments
  - Vertical and horizontal chemical slurry pumps; and heavy-duty paper stock pumps

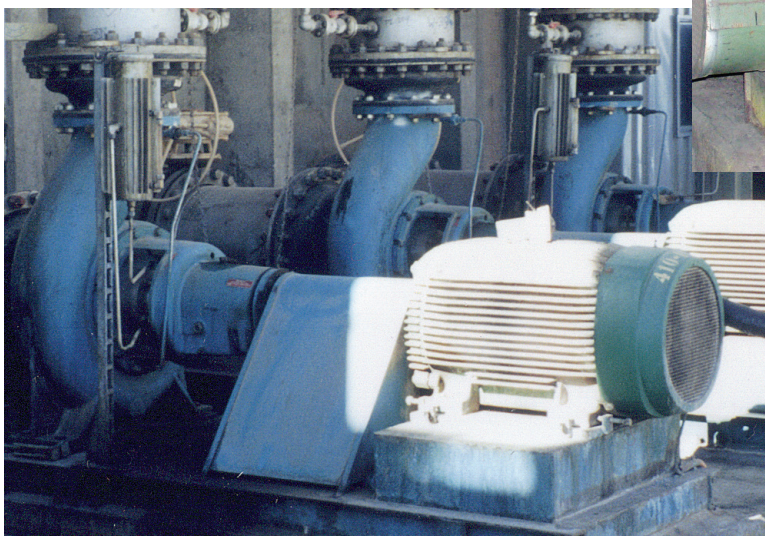
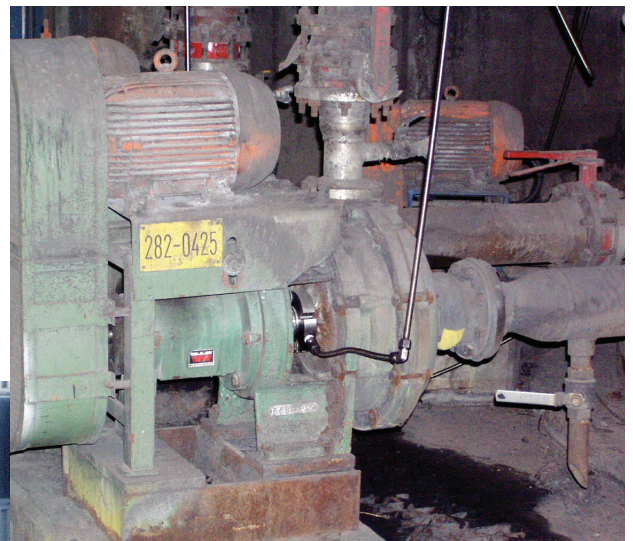
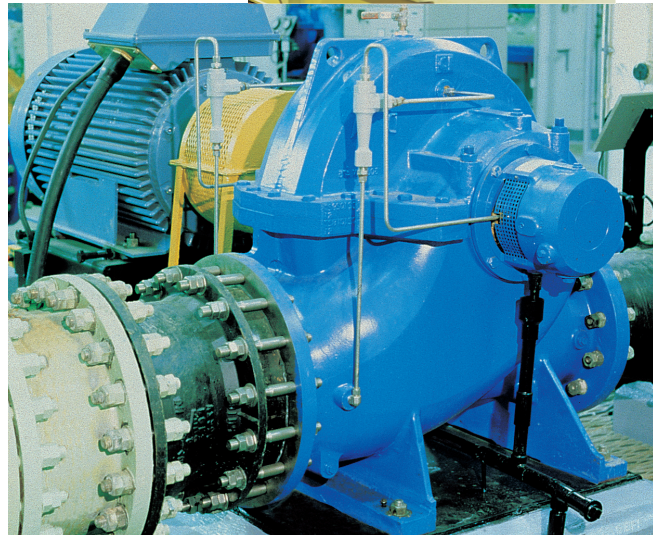

*Mill and  
Environmental  
Services*

Flowserve is among the world's largest industrial pump manufacturers. In addition to its capabilities in the pulp and paper industry, Flowserve is a leading supplier of pumps for power and steam generation, water resources and chemical processing. This strength permits Flowserve to satisfy virtually all its customers' plant-wide pumping needs, from process water to the power house to auxiliary services.

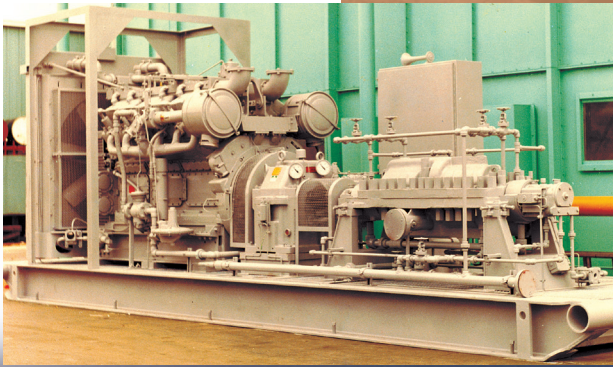

### ***Raw Water Supply***

Flowserve offers a complete line of efficient and reliable pumps with the flexibility to meet any application. Models include: double-suction, wet-pit volute pumps; one- and two-stage, deep-well, vertical turbine pumps; and horizontally split centrifugal pumps.



### ***Power Generation***

The comprehensive line of pump products and pumping systems manufactured by Flowserve is ideally suited for on-site power generation.

Services include:

- Boiler feed water
- Circulating water
- Condensate cooling water
- Flue gas desulfurization



### ***Pollution Control***

Pulp and paper mills implement costly abatement programs to reduce or eliminate pollutants, such as effluent solids, malodorous sulfur compounds and airborne particulate matter. Flowserve produces a variety of vertical and horizontal solids-handling pumps for concentrating and dewatering sludge and chemically laden waste streams.

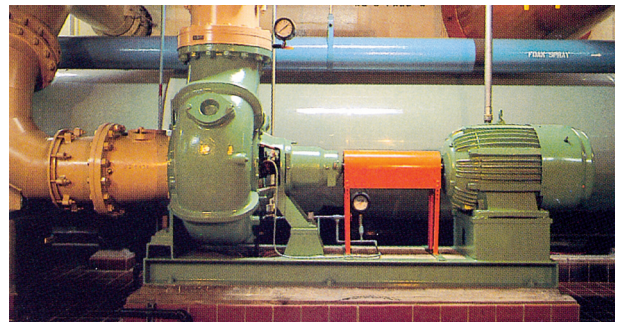

### ***Auxiliary Services***

- System protection
- Sump drain off
- Safety systems
- High-pressure washdown
- General service

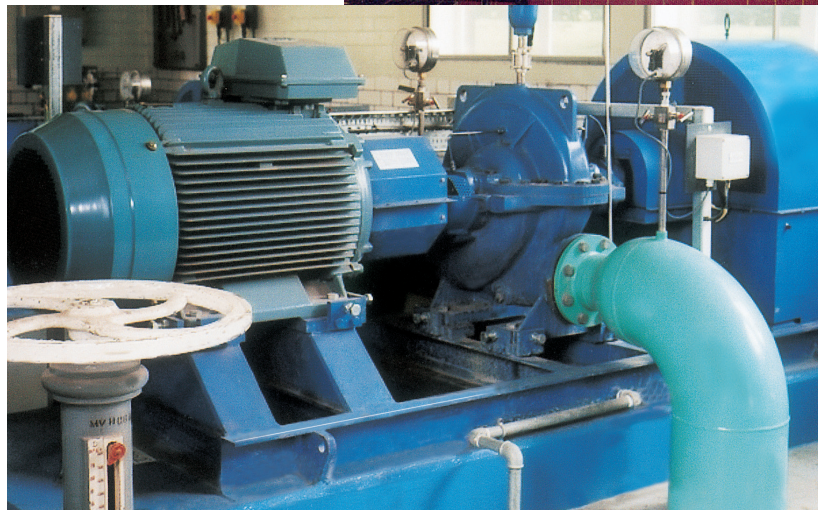

**Paper Stock Pumps**

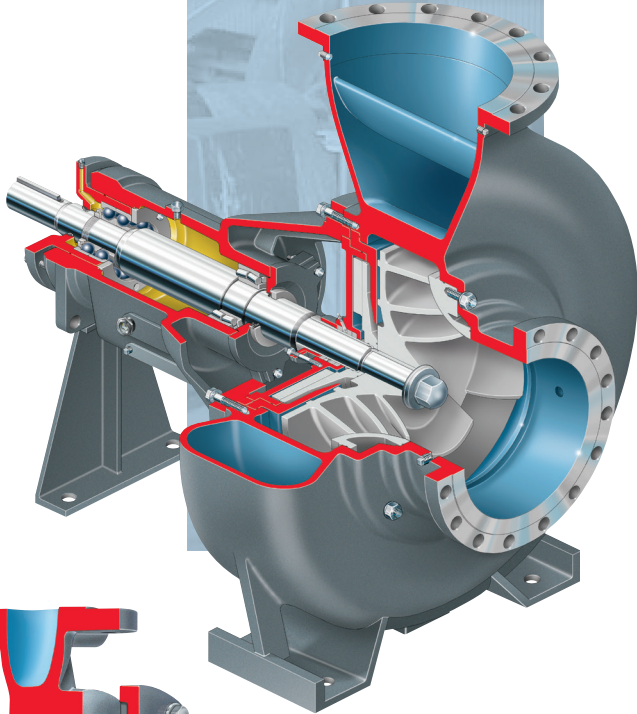

**Heavy-Duty, Paper Stock Process Pumps**

Horizontal and vertical designs available

**Operating Parameters**

- Flows to 9085 m<sup>3</sup>/h (40 000 gpm)
- Heads to 100 m (330 ft)
- Pressures to 14 bar (200 psi)
- Temperatures to 150°C (300°F)

**ASME (ANSI) and ISO Recessed Impeller Chemical Process Pumps**

Horizontal, single-stage, recessed impeller, chemical process pumps to ASME B73.1 and ISO 2858-5199

**Operating Parameters**

- Flows to 455 m<sup>3</sup>/h (2000 gpm)
- Heads to 120 m (400 ft)
- Pressures to 25 bar (365 psi)
- Temperatures to 370°C (700°F)

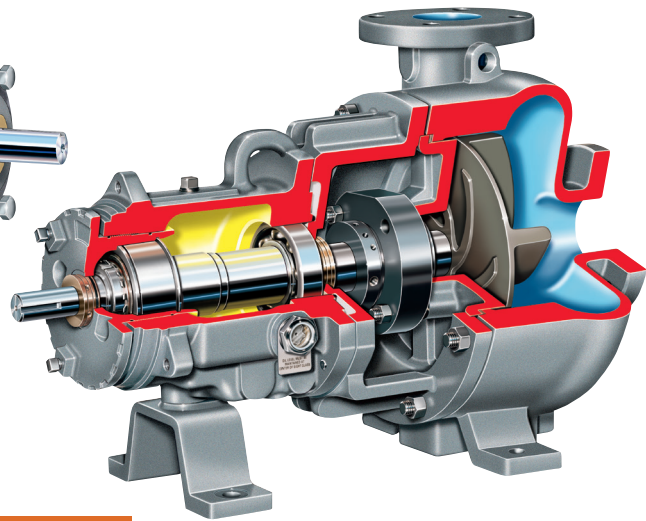
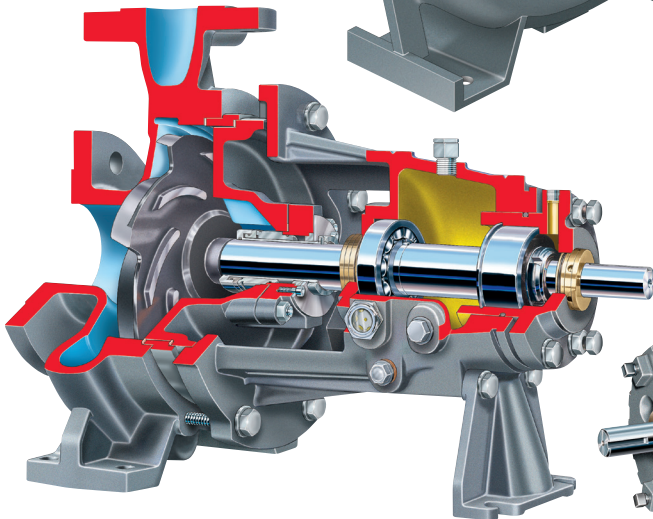

**Centerline-Mounted Process Pumps**

Horizontal, single-stage, end suction top discharge, centerline-mounted, API standard process pumps

**Operating Parameters**

- Flows to 2000 m<sup>3</sup>/h (8800 gpm)
- Heads to 350 m (1100 ft)
- Pressures to 80 bar (1160 psi)
- Temperatures to 450°C (840°F)

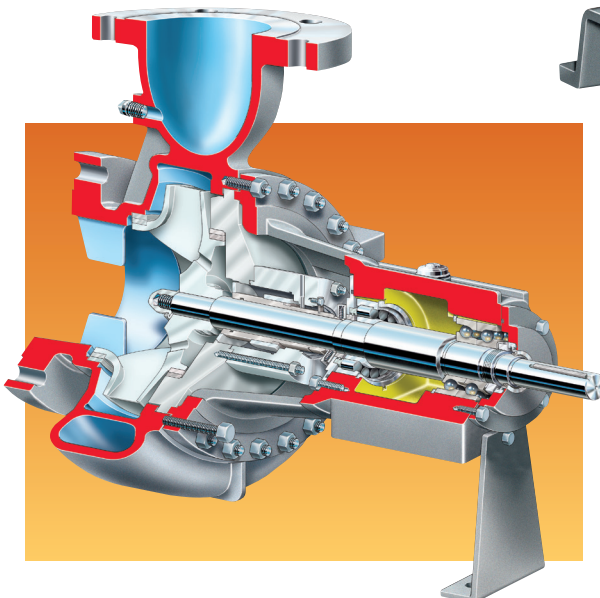



### Vertical Turbine Pumps

Multistage with above- or below-ground discharge, enclosed or semi-open impellers, open or enclosed lineshafts, single or double casing

#### Operating Parameters

- Flows to 13 600 m<sup>3</sup>/h (60 000 gpm)
- Heads to 700 m (2300 ft)
- Pressures to 100 bar (1450 psi)
- Temperatures to 300°C (570°F)

### Wet-Pit, Vertical Pumps

Vertical, wet-pit, double-suction impeller, between bearings, double volute centrifugal pumps with enclosed or open lineshafts

#### Operating Parameters

- Flows to 25 000 m<sup>3</sup>/h (110 000 gpm)
- Heads to 500 m (1640 ft)
- Pressures to 70 bar (1015 psi)
- Temperatures to 200°C (400°F)

### Between Bearings, Single-Stage Pumps

Horizontal, axially split, single-stage, double-suction centrifugal pumps. Pump configurations include a vertical mounted option and selected sizes of bottom suction models.

#### Operating Parameters

- Flows to 30 000 m<sup>3</sup>/h (132 000 gpm)
- Heads to 300 m (980 ft)
- Pressures to 40 bar (580 psi)
- Temperatures to 140°C (285°F)

### Multistage, Segmental Ring Pumps

Between bearings, radially split, high-pressure designs

#### Operating Parameters

- Flows to 190 m<sup>3</sup>/h (800 gpm)
- Heads to 700 m (2300 ft)
- Pressures to 75 bar (1090 psi)
- Temperatures to 210°C (410°F)

## Water-Handling Pumps

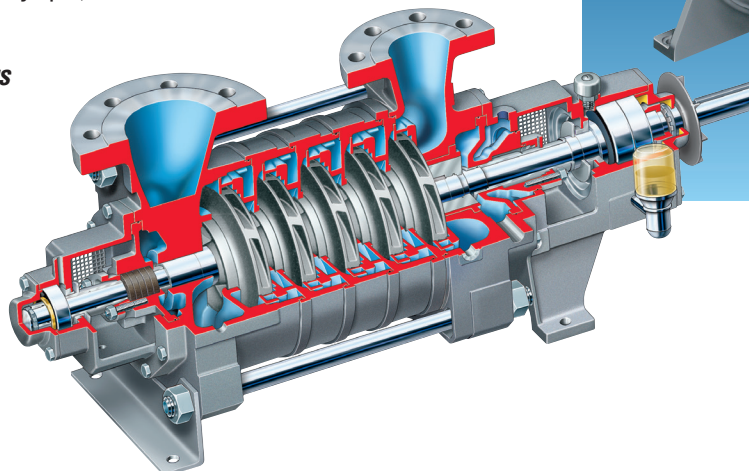
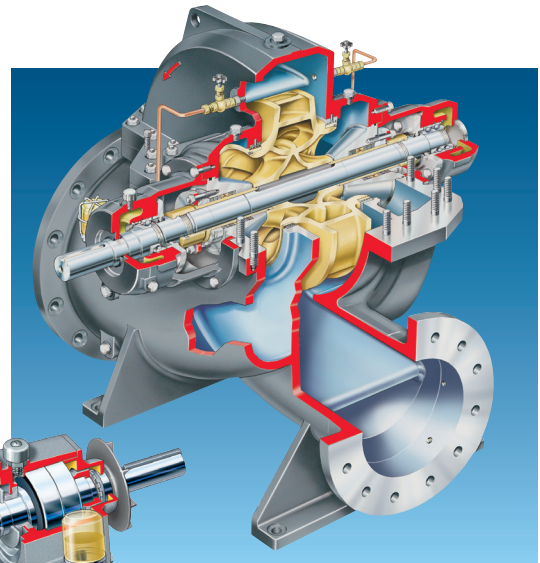
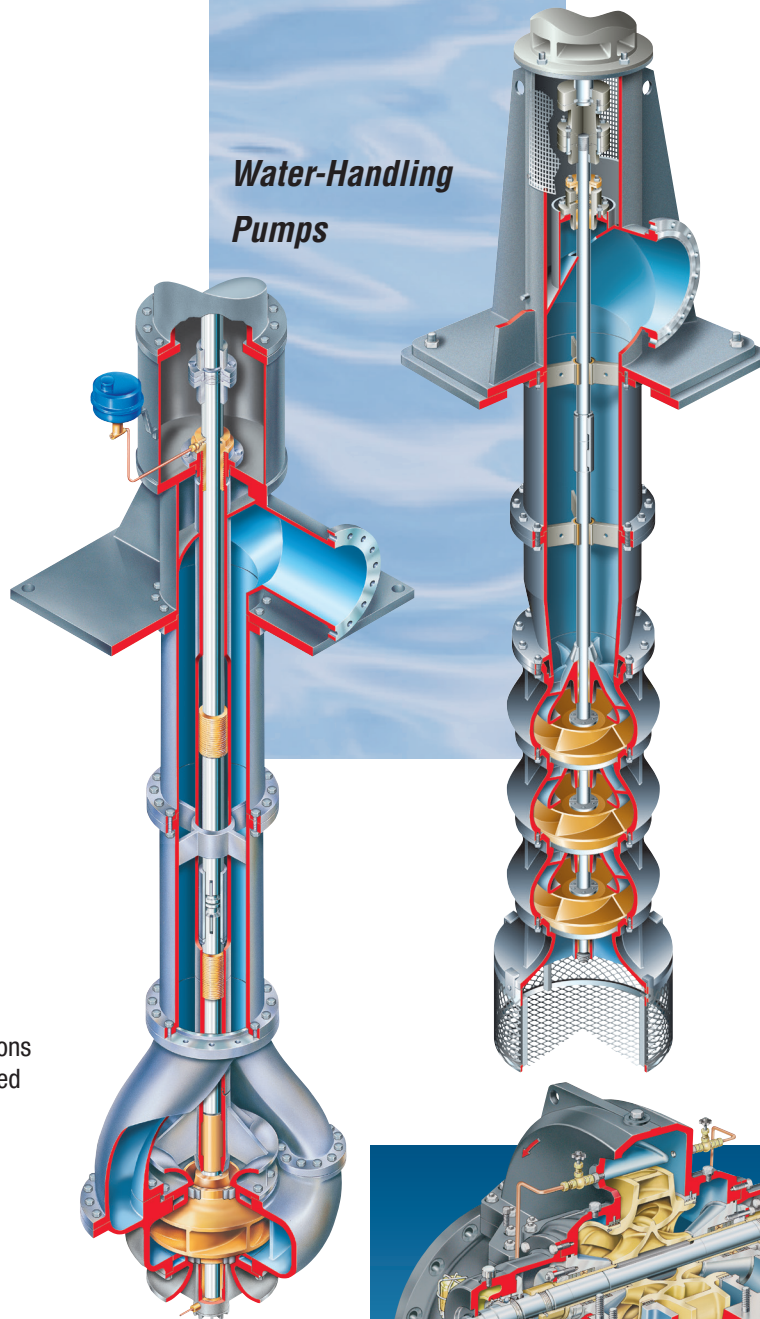



## Chemical Process Pumps

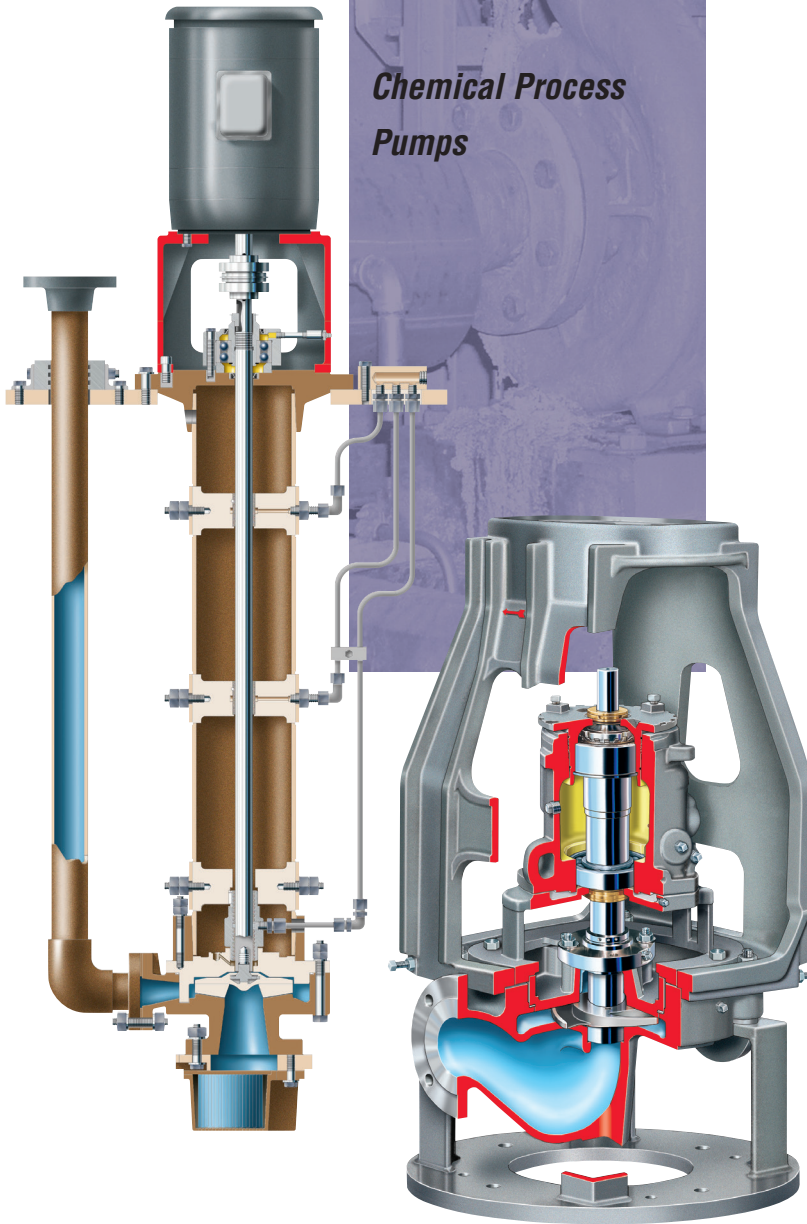

### Vertical Sump Pumps

Versatile, fiber-reinforced polymer and metallic designs for corrosive services

#### Operating Parameters

- Flows to 1400 m<sup>3</sup>/h (6160 gpm)
- Heads to 250 m (820 ft)
- Pressures to 25 bar (365 psi)
- Temperatures to 350°C (660°F)

### ASME (ANSI) Chemical Process Pumps

Horizontal, single-stage, chemical process pumps to ASME B73.1 and vertical in-line chemical pumps to ASME B73.2

#### Operating Parameters

- Flows to 4540 m<sup>3</sup>/h (20 000 gpm)
- Heads to 300 m (985 ft)
- Pressures to 27 bar (400 psi)
- Temperatures to 370°C (700°F)

### ASME (ANSI) and ISO Non-metallic Process Pumps

Horizontal, single-stage, chemical process pumps to ASME B73.1, ASME B73.5 or ISO 2858

#### Operating Parameters

- Flows to 2050 m<sup>3</sup>/h (9000 gpm)
- Heads to 150 m (500 ft)
- Pressures to 17 bar (250 psi)
- Temperatures to 150°C (300°F)

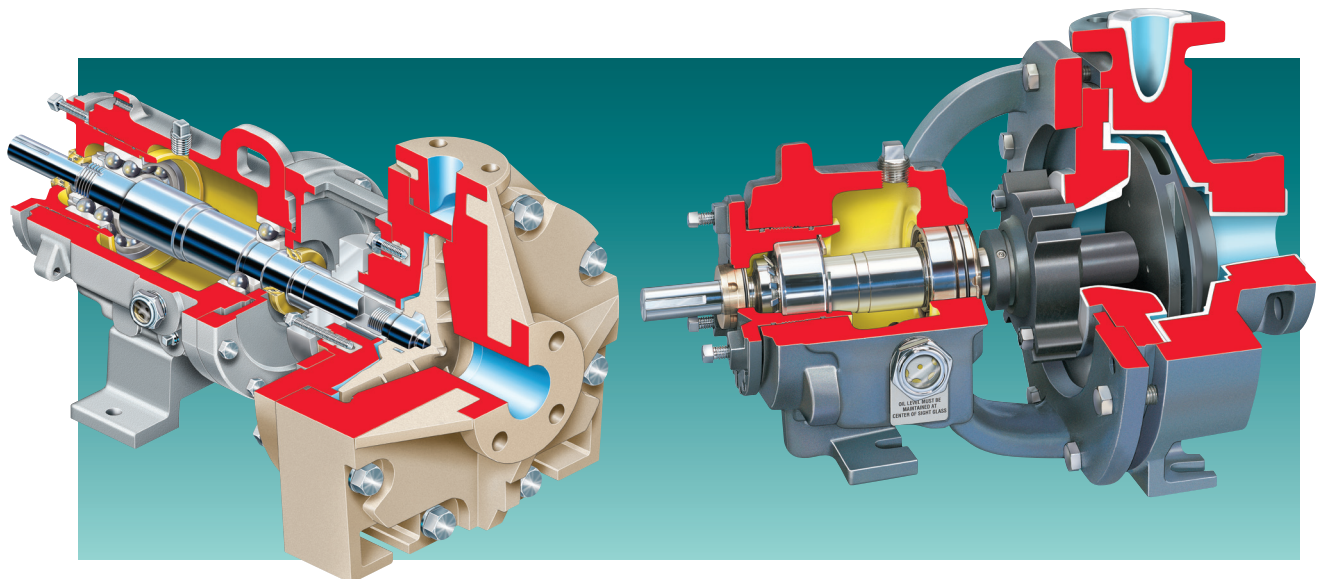

## Hard Metal Abrasive Slurry Pumps

Horizontal and vertical designs available

### Operating Parameters

- Flows to 10 000 m<sup>3</sup>/h (44 000 gpm)
- Heads to 90 m (300 ft)
- Pressures to 50 bar (725 psi)
- Temperatures to 120°C (250°F)

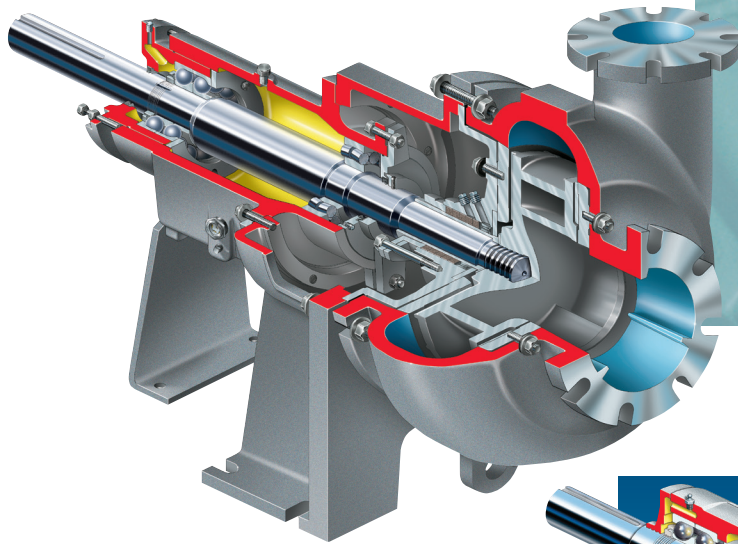

## Abrasive Slurry Pumps

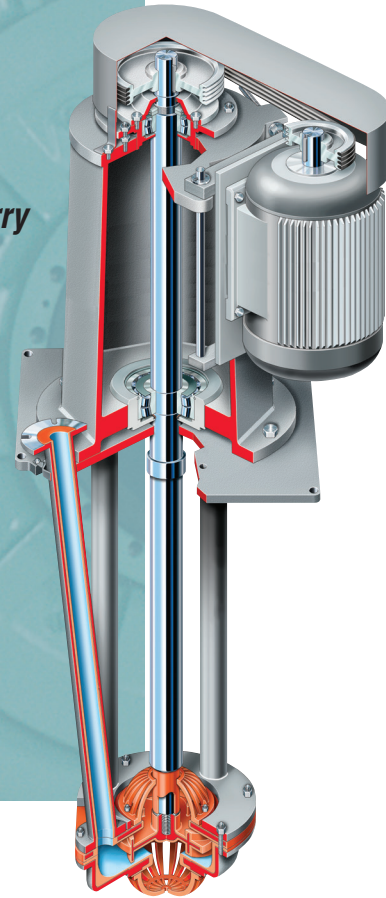

## Chemical Slurry Pumps

Horizontal and vertical designs available

### Operating Parameters

- Flows to 8000 m<sup>3</sup>/h (35 200 gpm)
- Heads to 90 m (300 ft)
- Pressures to 25 bar (360 psi)
- Temperatures to 140°C (285°F)

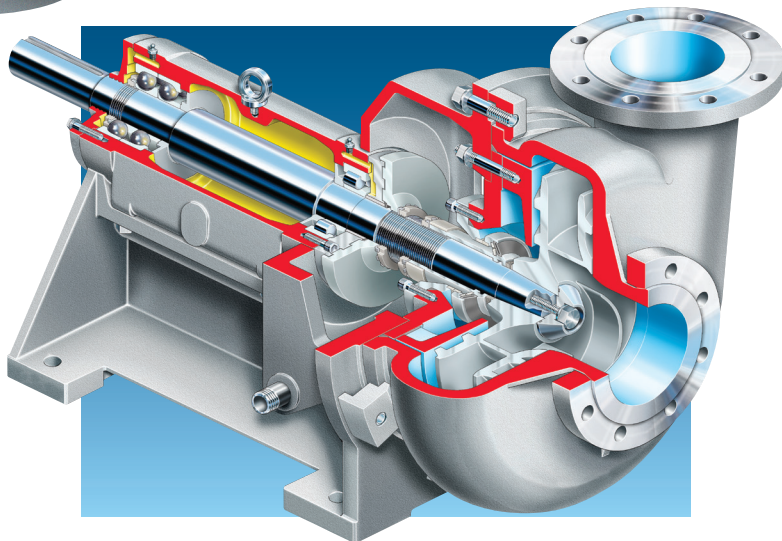

## Rubber-Lined Abrasive Slurry Pumps

Horizontal and vertical designs available

### Operating Parameters

- Flows to 10 000 m<sup>3</sup>/h (44 000 gpm)
- Heads to 90 m (300 ft)
- Pressures to 40 bar (580 psi)
- Temperatures to 110°C (225°F)

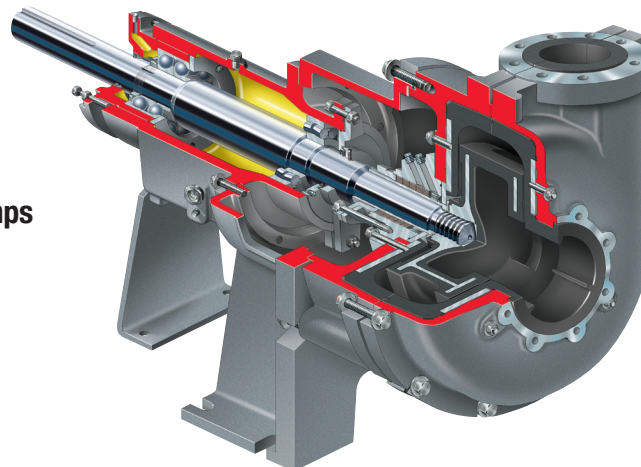

*High-Viscosity,  
Special Service  
Pumps*

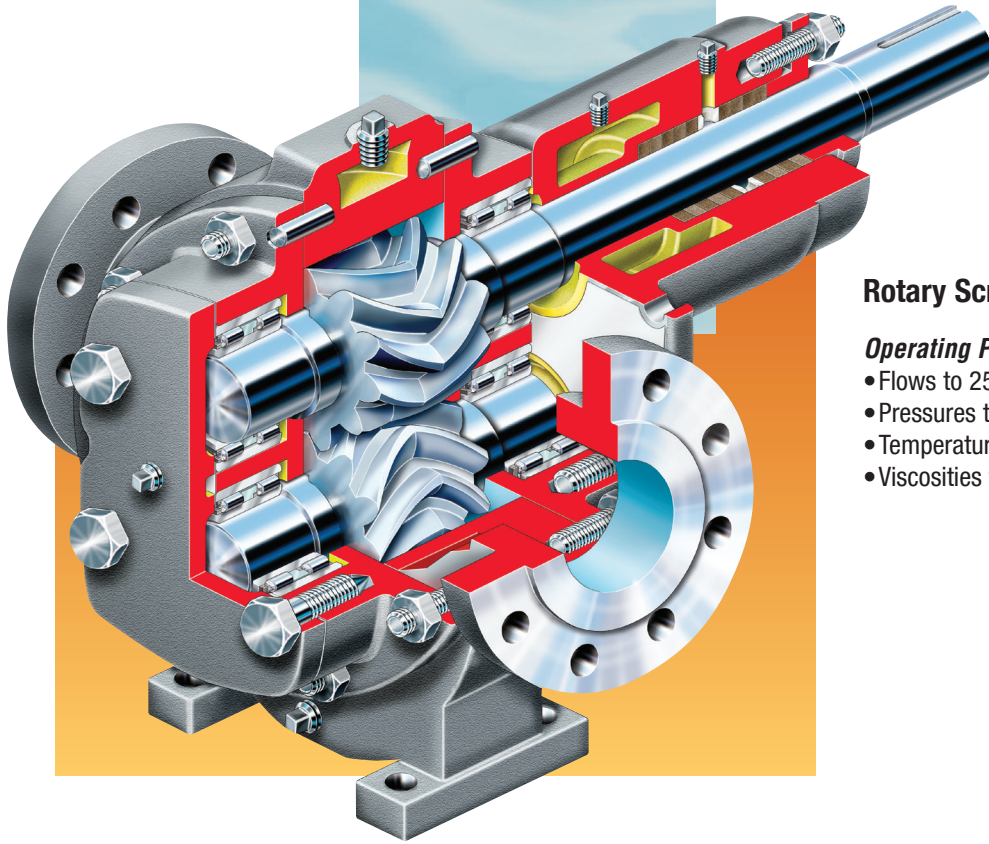

**Rotary Gear Pumps**

***Operating Parameters***

- Flows to 275 m<sup>3</sup>/h (1200 gpm)
- Pressures to 35 bar (500 psi)
- Temperatures to 450°C (850°F)
- Viscosities to 20 000 cP

**Rotary Screw Pumps**

***Operating Parameters***

- Flows to 2550 m<sup>3</sup>/h (11 200 gpm)
- Pressures to 100 bar (1450 psi)
- Temperatures to 450°C (850°F)
- Viscosities to 55 000 000 cP

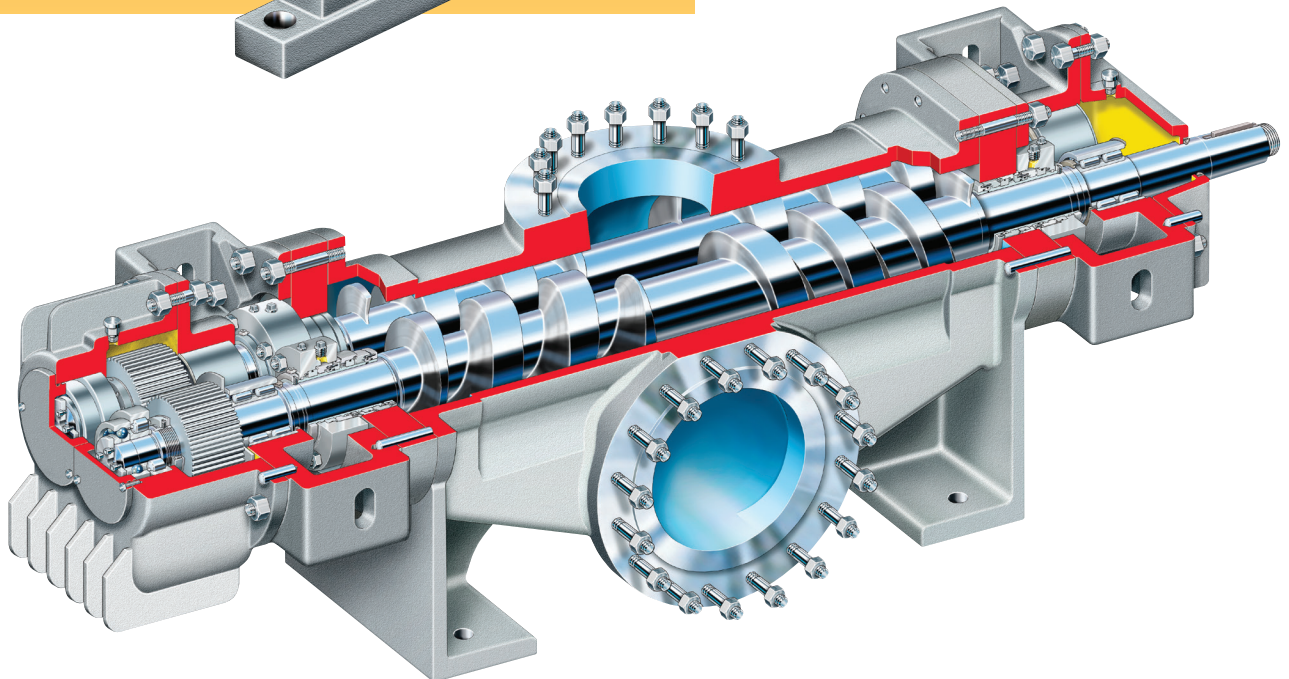

### Multistage, Axially Split Volute Pumps

Between bearings, double volute, side suction, side discharge

#### Operating Parameters

- Flows to 2950 m<sup>3</sup>/h (13 000 gpm)
- Heads to 2130 m (7000 ft)
- Pressures to 275 bar (4000 psi)
- Temperatures to 200°C (400°F)

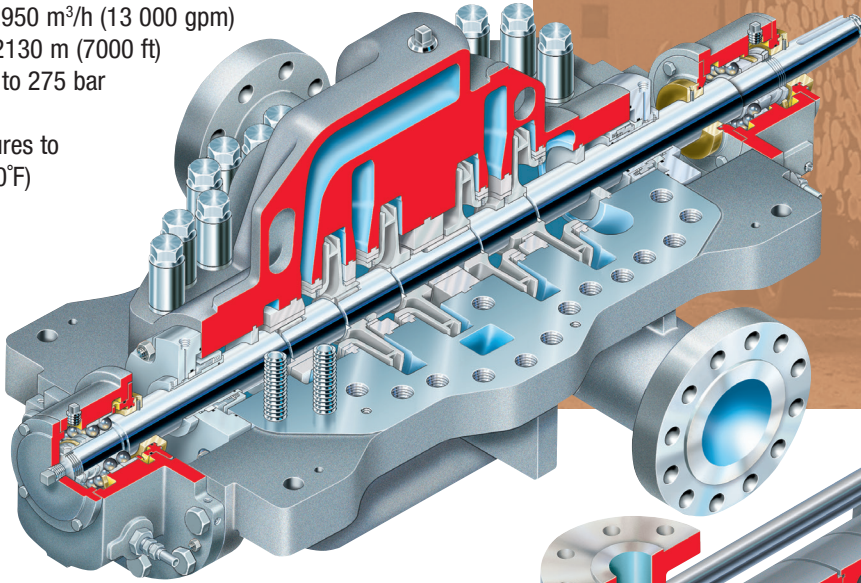

### Power Generation and Pollution Control Pumps

### Multistage, Segmental Ring Diffuser Pumps

Between bearings, radially split, multistage designs

#### Operating Parameters

- Flows to 900 m<sup>3</sup>/h (4000 gpm)
- Heads to 2650 m (8700 ft)
- Pressures to 250 bar (3625 psi)
- Temperatures to 250°C (480°F)

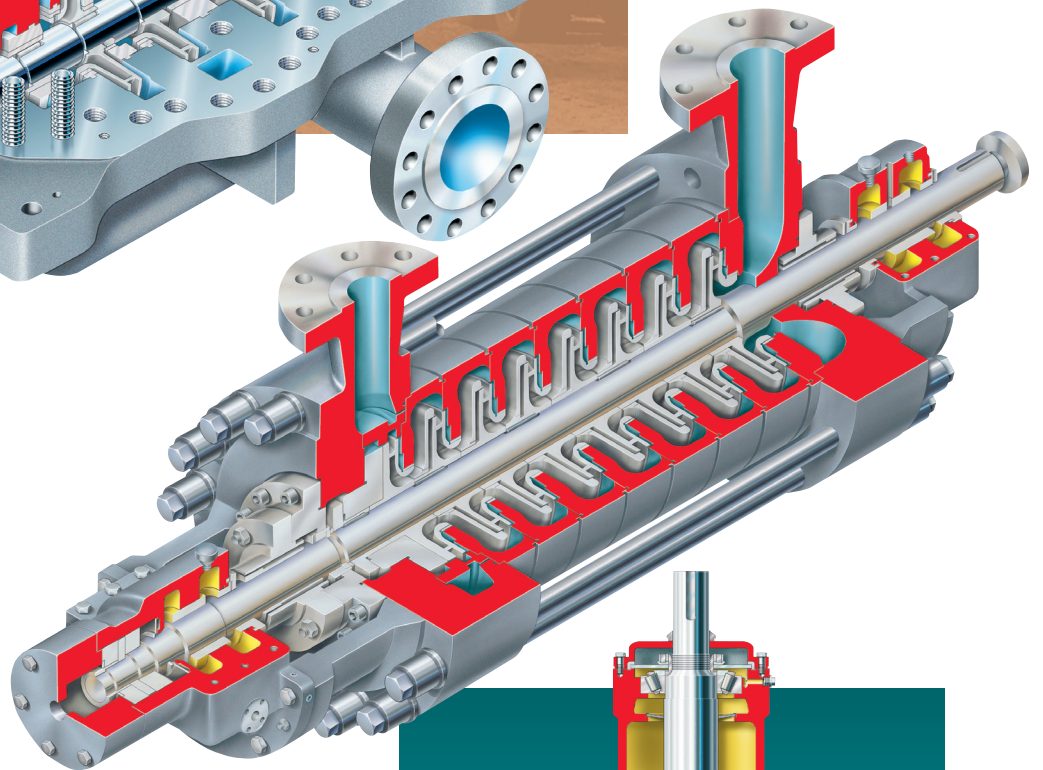

### End Suction, Side Discharge, Mixed-Flow, Non-Clog Pumps

Single-stage, overhung, non-clogging impeller; horizontal frame mounted, vertical frame mounted, or independently mounted motor, including extended shafting

#### Operating Parameters

- Flows to 45 500 m<sup>3</sup>/h (200 000 gpm)
- Heads to 90 m (300 ft)
- Sizes to 1800 mm (72 in)

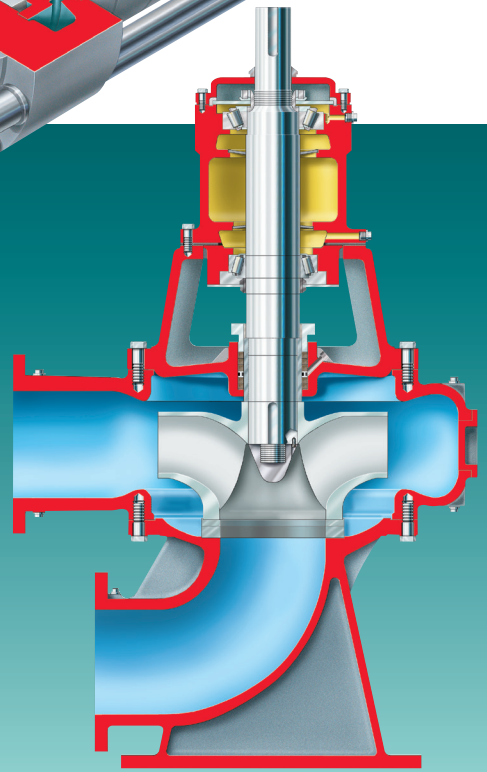



**Technology, Technical Support and Service**

**Innovation Through Dynamic Technology**

Flowserve is without peer in the development, refinement and application of pump technology. This dynamic creativity is reflected in the strength of the company's commitment to:

- Hydraulic engineering
- Mechanical design
- Materials science
- Intelligent pumping
- Manufacturing technology

All research and technology efforts are directed toward providing customers with greater total value for their investments in Flowserve products and systems.

"Further, these capabilities enable Flowserve to quickly and "accurately provide the best possible solutions to customers' specific pumping problems.

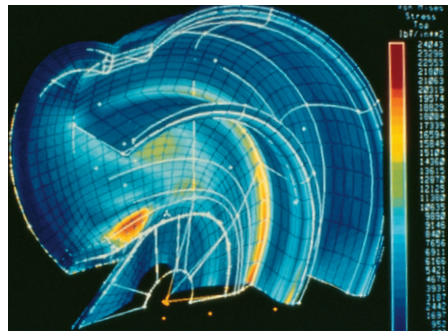
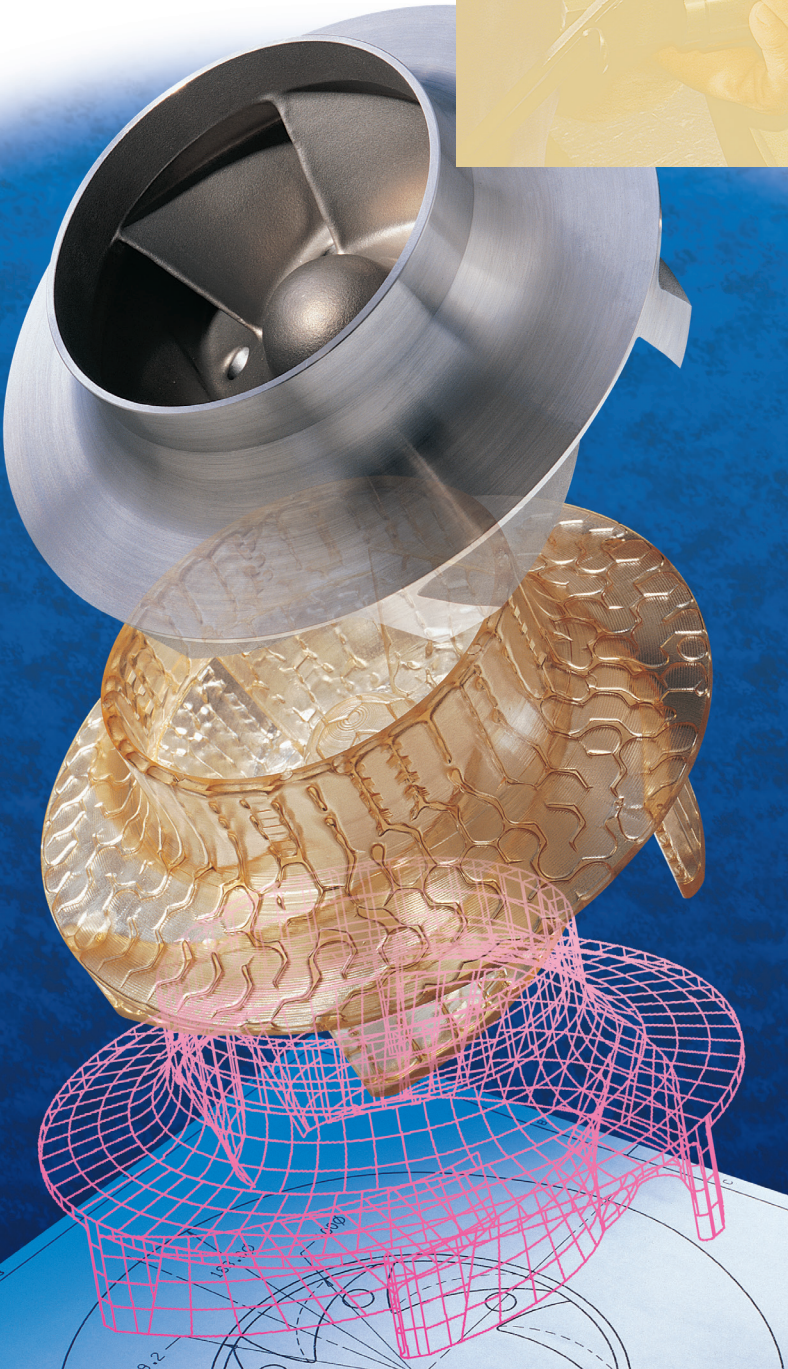

**Pump Improvement Engineering Services**

The goal of this specialty service is to help plant technical personnel achieve optimal pumping solutions through engineering and technological assistance. Reducing the costs of operation and maintenance while improving overall equipment reliability is achieved through:

- Field performance testing
- Vibration analysis
- Design analysis and root-cause problem solving
- Material improvements
- Pump and system audits
- Advanced technology solutions
- Nuclear Maintenance Rule support
- PumpTrac™ remote pump monitoring and diagnostic services
- Instruction manual updates
- Training courses

**Parts and Service**

Quality OEM parts are readily available from a worldwide network of Flowserve service and repair centers, fast response centers and regional parts service offices. All are computer networked to provide “as soon as possible” response to customers’ requests for assistance.

Customer service technicians are on call around the clock, seven days a week to respond to customer queries, evaluate and troubleshoot reported pump problems and provide reliable solutions.



**Engineered Services**

Flowserve Engineered Services is dedicated to maximizing equipment performance and reliability-centered maintenance programs. Pump-related services include:

- Start-up and commissioning
- Diagnostics and prognostics
- Contract maintenance programs
- Routine and repair maintenance
- ANSI and ISO power end exchange program
- Mechanical seal exchange program
- Re-rates, upgrades and retrofits
- Spare parts inventory and management programs
- Training

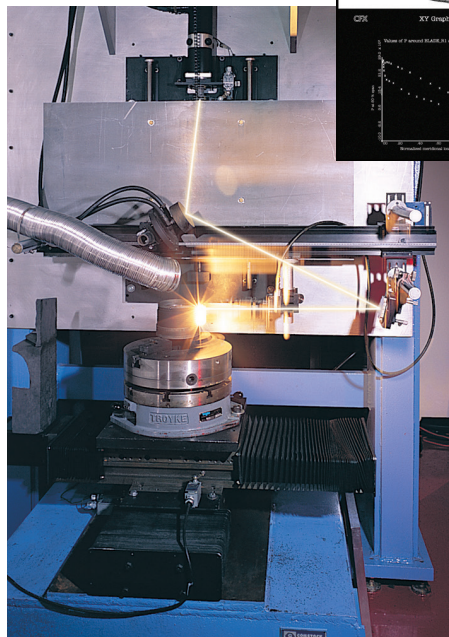
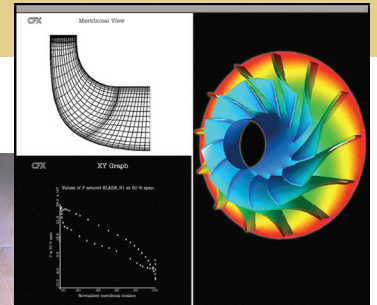

*Flowserve... Supporting Our Customers  
With The World's Leading  
Pump Brands*



**USA and Canada**

Flowserve Corporation  
5215 North O'Connor Blvd.  
Suite 2300  
Irving, Texas 75039-5421 USA  
Telephone: +1 937 890 5839

**Europe, Middle East, Africa**

Flowserve Corporation  
Parallelweg 13  
4878 AH Etten-Leur  
The Netherlands  
Telephone: +31 76 502 8100



*Your local Flowserve representative:*

**To find your local Flowserve representative,  
please use the Sales Support Locator System  
found at [www.flowserve.com](http://www.flowserve.com)  
or call: +1 937 890 5839.**

**Latin America**

Flowserve Corporation  
Martín Rodríguez 4460  
B1644CGN-Victoria-San Fernando  
Buenos Aires, Argentina  
Telephone: +54 11 4006 8700  
Telefax: +54 11 4714 1610

**Asia Pacific**

Flowserve Pte. Ltd.  
10 Tuas Loop  
Singapore 637345  
Telephone: +65 6771 0600  
Telefax: +65 6862 2329