

FLowsERVE



MSX
Solids Handling,
Submersible
Pumps

Pump Supplier To The World

Flowserve is the driving force in the global industrial pump marketplace. No other pump company in the world has the depth or breadth of expertise in the successful application of pre-engineered, engineered, and special purpose pumps and systems.

Pumping Solutions

Flowserve is providing pumping solutions that permit customers to continuously improve productivity, profitability and pumping system reliability.

Market-Focused Customer Support

Product and industry specialists develop effective proposals and solutions directed toward market and customer preferences. They offer technical advice and assistance throughout each stage of the product life cycle, beginning with the inquiry.



Dynamic Technologies

Flowserve is without peer in the development and application of pump technology, including:

- Hydraulic engineering
- Mechanical design
- Materials science
- Intelligent pumping
- Manufacturing technology

Broad Product Lines

Flowserve offers a wide range of complementary pump types, from pre-engineered process pumps, to highly engineered and special purpose pumps and systems. Pumps are built to recognized global standards and customer specifications.

Pump designs include:

- Single-stage process
- Between bearing single-stage
- Between bearing multistage
- Vertical
- Submersible motor
- Positive displacement
- Nuclear
- Specialty

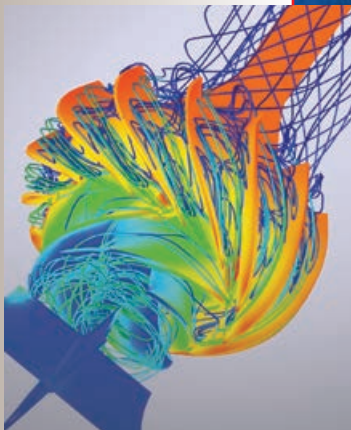
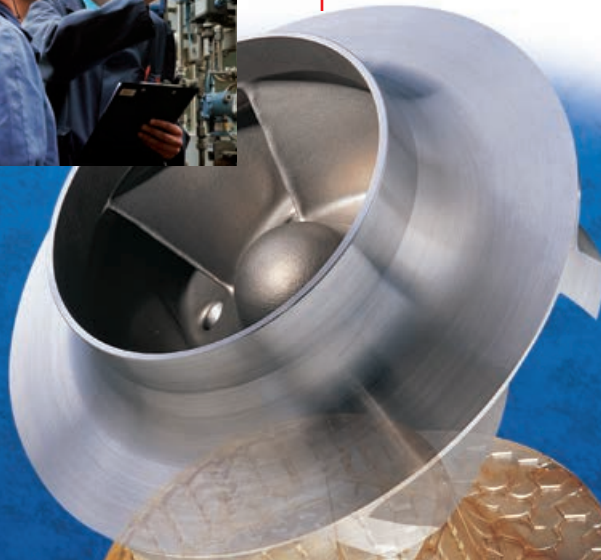

**MSX
Solids Handling,
Submersible
Pumps**

Rugged and Reliable

The Flowserve MSX family of solids handling, submersible pumps is engineered to perform efficiently in the most challenging environments, from pumping raw sewage to moving industrial wastewater and other solid-laden liquids.

**Operating and
Cost-Saving Benefits**

MSX non-clog pumps reduce operating costs while providing long-life operation with minimal downtime.

- High efficiency
 - Superior hydraulic capability
 - Outstanding wire-to-water efficiency
 - EPACT-rated high performance motors
 - Complete hydraulic and motor coverage
- Solid reliability
 - Long-lasting seal and bearing designs
 - Closed-loop cooling system for improved heat transfer
 - Spike-resistant windings for extended motor life
 - High-quality materials of construction

Broad Application

- Raw sewage
- Return-activated sludge
- Waste-activated sludge
- Mixed liquor
- Final effluent
- Filter backwash
- Dewatering
- Industrial process
- Industrial waste collection
- Flood protection

**Complementary
Pump Designs**

Depending upon application requirements, Flowserve can also provide these pump designs:

- End suction, side-discharge, mixed-flow, non-clog pumps
- Vertical, wet-pit pumps

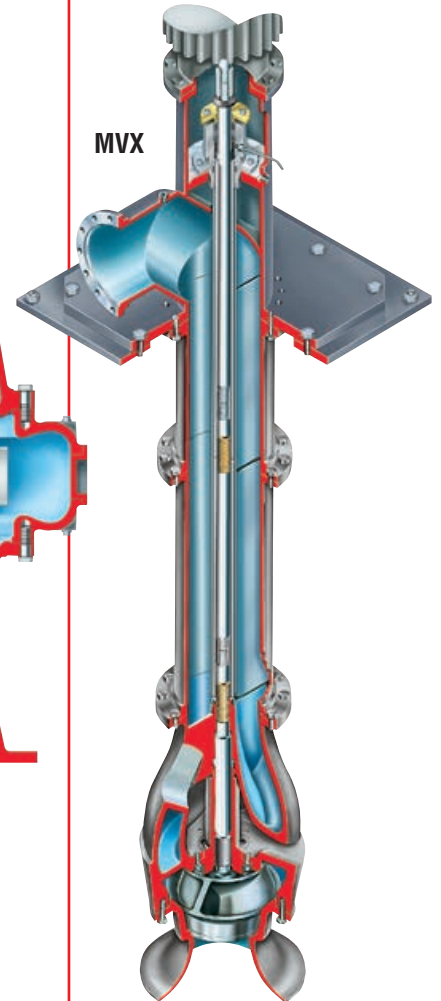
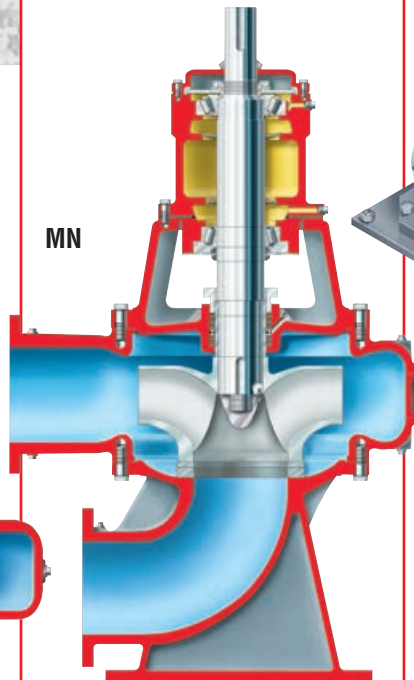
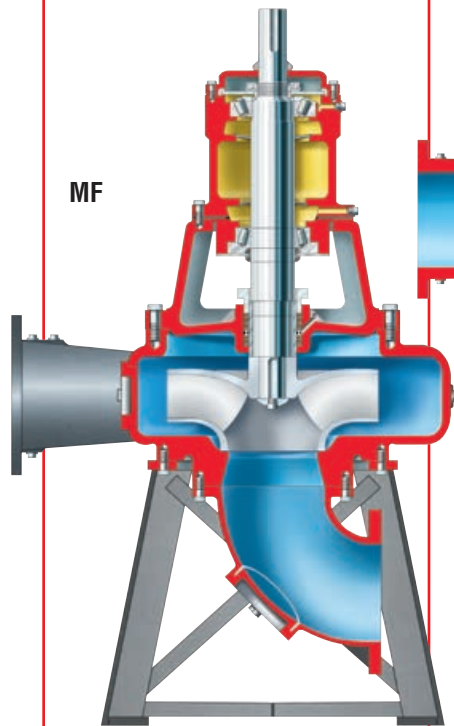

MSX
Solids Handling,
Submersible
Pumps

Flowserve MSX pumps are expressly designed to handle sewage and wastes of almost every form and description, including both solids in solution and solids in suspension. Absolute reliability is the most critical requirement for these pumps. MSX-Series 1 medium-capacity and MSX-Series 2/3 high-capacity pumps provide that assurance along with long life, cost-efficient performance.

Operating Parameters

- Flows to 4545 m³/h (20 000 gpm)
- Heads to 90 m (300 ft)
- Sizes 80 mm (3 in) to 500 mm (20 in)
- Motors to 224 kW (300 hp)
 - FM-approved version available for explosion-proof service
 - Variable-speed drives available
- Solids handling capability to 80 mm (3 in) spherical

Industries Served

- Water resources
- Mining
- Agriculture
- General industry

Accessories

- Control panels
- Lifting chains
- Access covers
- Guide rail assemblies
- Level control floats
- Telemetry devices
- Valves

MSX-Series 1 Design Features

EPACT Rated Motor* offers high-efficiency performance for impressive energy savings.

Shaft and Rotor are dynamically balanced for reduced vibration to assure smooth operation and long service life.

Class H Rated Insulation System significantly extends motor life.

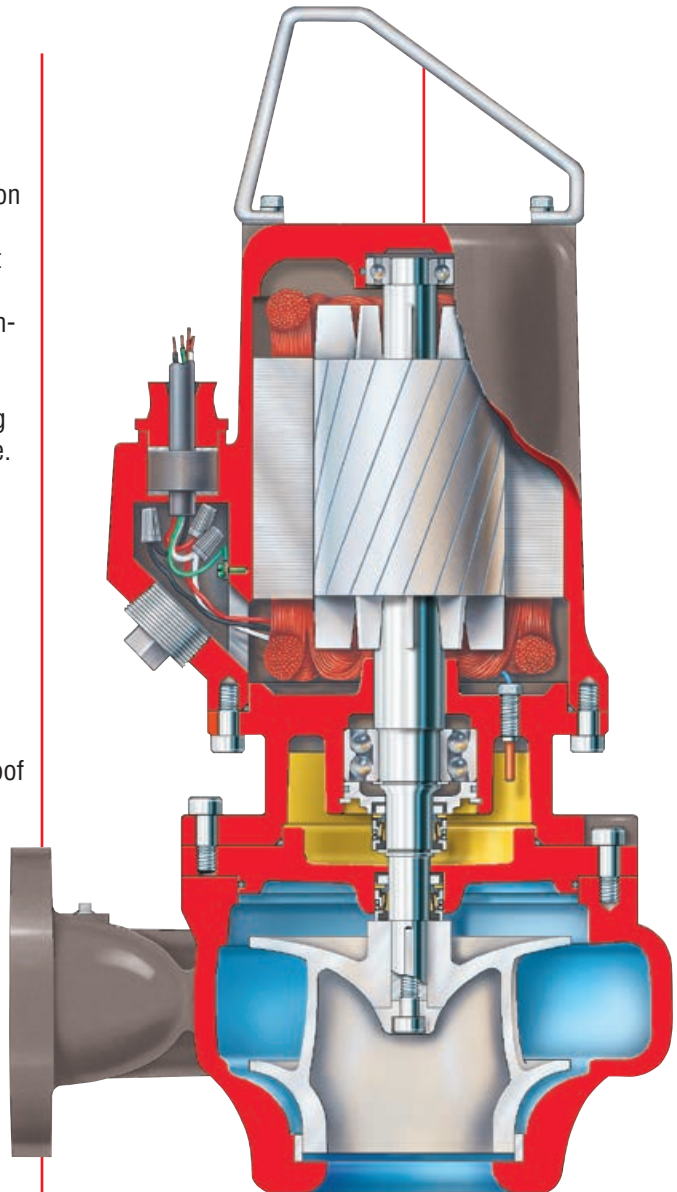

Watertight Cable Entry protects motor from moisture and contamination, thus extending its operating life.

Impeller Wear Ring in stainless steel available as an option for extended impeller life.

Spike-Resistant Windings are standard. In addition to smooth, consistent motor performance, this feature permits the handling of voltage spikes with variable frequency drive motor option.

Long-Life, Angular Contact Bearings support axial and radial thrust loads for superior bearing and seal life.

Sealing Fluid is environmentally friendly to eliminate media contamination concerns.

Silicon Carbide Seal Faces in the lower mechanical seals provide durability and reliability. Upper mechanical seal faces are carbon/ceramic.

High-Efficiency Hydraulics reduce energy consumption and operating cost while providing constant, predictable pumping performance.

Extensive Hydraulic Coverage is achieved with discharge sizes of 80 mm (3 in) through 150 mm (6 in).

Higher Overall Wire-to-Water Efficiencies.

* First motor to meet U.S. Energy Policy Act's (EPACT) efficiency regulations

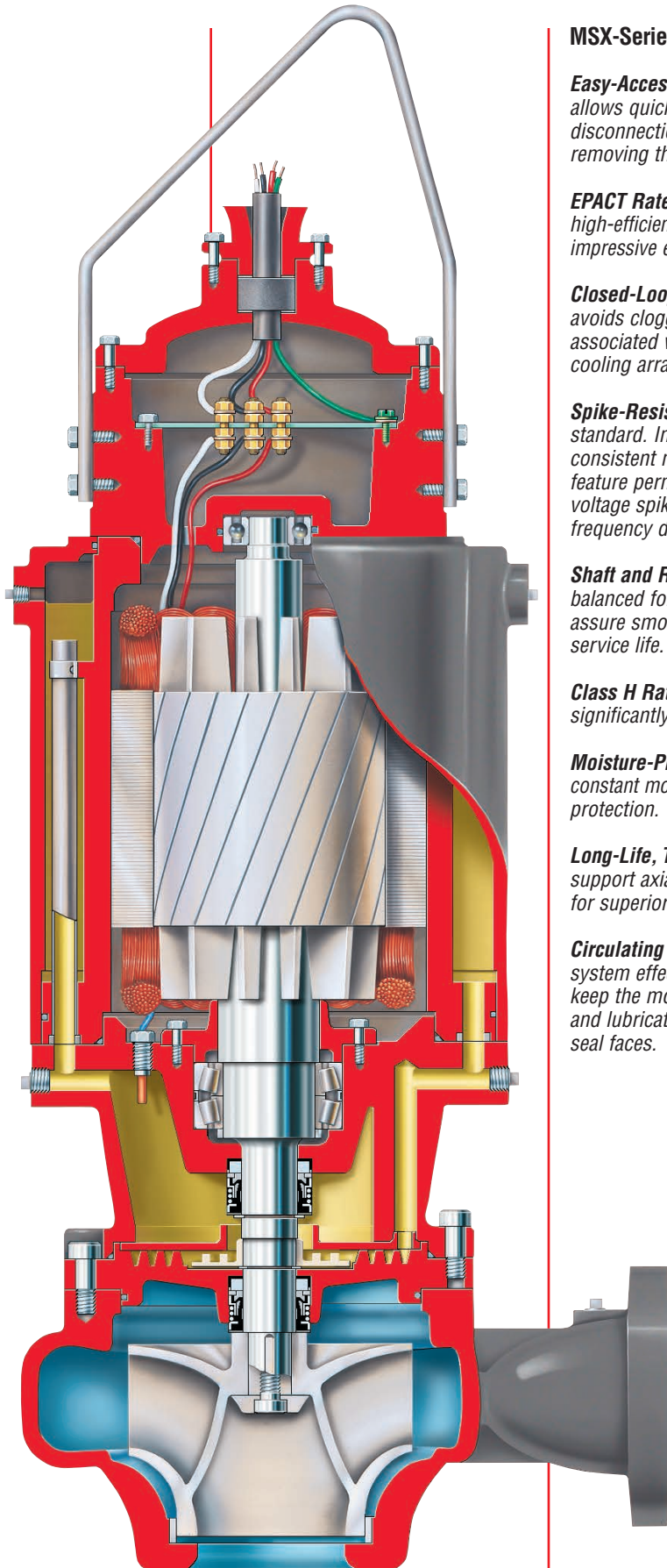

MSX-Series 2/3 Design Features

Easy-Access Terminal Chamber allows quick power connection-disconnection without entirely removing the pump from service.

EPACT Rated Motor* offers high-efficiency performance for impressive energy savings.

Closed-Loop Cooling Design avoids clogging and hot spots associated with pumped media cooling arrangements.

Spike-Resistant Windings are standard. In addition to smooth, consistent motor performance, this feature permits the handling of voltage spikes with variable frequency drive motor option.

Shaft and Rotor are dynamically balanced for reduced vibration to assure smooth operation and long service life.

Class H Rated Insulation System significantly extends motor life.

Moisture-Protection Probe provides constant monitoring and motor protection.

Long-Life, Tapered Roller Bearings support axial and radial thrust loads for superior bearing and seal life.

Circulating Impeller in the cooling system effectively transfers heat to keep the motor running smoothly and lubricate the upper mechanical seal faces.

Sealing and Cooling Oil are environmentally friendly to eliminate contamination concerns.

Heat Exchanger in the closed loop cooling system provides additional motor cooling protection.

Impeller Wear Ring supplied in hardened stainless steel as a standard for extended impeller life.

Silicon Carbide Seal Faces in the lower mechanical seals provide durability and reliability. Upper mechanical seal faces are carbon/ceramic.

High-Efficiency Hydraulics reduce energy consumption and operating costs while providing constant, predictable pumping efficiency.

High Overall Wire-to-Water Efficiencies.

Technical Data and Options

Wet-Pit Mounting Option

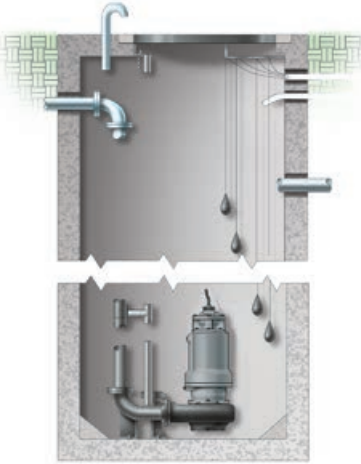

Dry-Pit Mounting Option



Transportable Option



Complementary Equipment

- Controls
- Level switches
- Valves
- Access covers
- Hoists
- Testing

Component	Standard Materials
Pump Casing	Cast Iron, ASTM A48, CL30
Casing Wear Ring	Cast Iron, ASTM A48, CL30 or ASTM A743, Grade CA40
Impeller	Cast Iron, ASTM A48, CL30
Impeller Wear Ring	ASTM A487, Grade CA15
Motor Housing	Cast Iron, ASTM A48, CL30
Cooling Jacket	Cast Iron, ASTM A48, CL30
Seal Plate	Cast Iron, ASTM A48, CL30
Bearing Plate	Cast Iron, ASTM A48, CL30
Cable Entry	Cast Iron, ASTM A48, CL30
Hardware	Type 316 SS
Shaft	Type 416 SS
O-Rings	Buna-N
Cable Entry Grommet	Neoprene
Exterior Coatings	Corrosion-resistant paint
Impeller Key/Bolt	Type 416 SS/Type 316 SS

MSX Range Chart

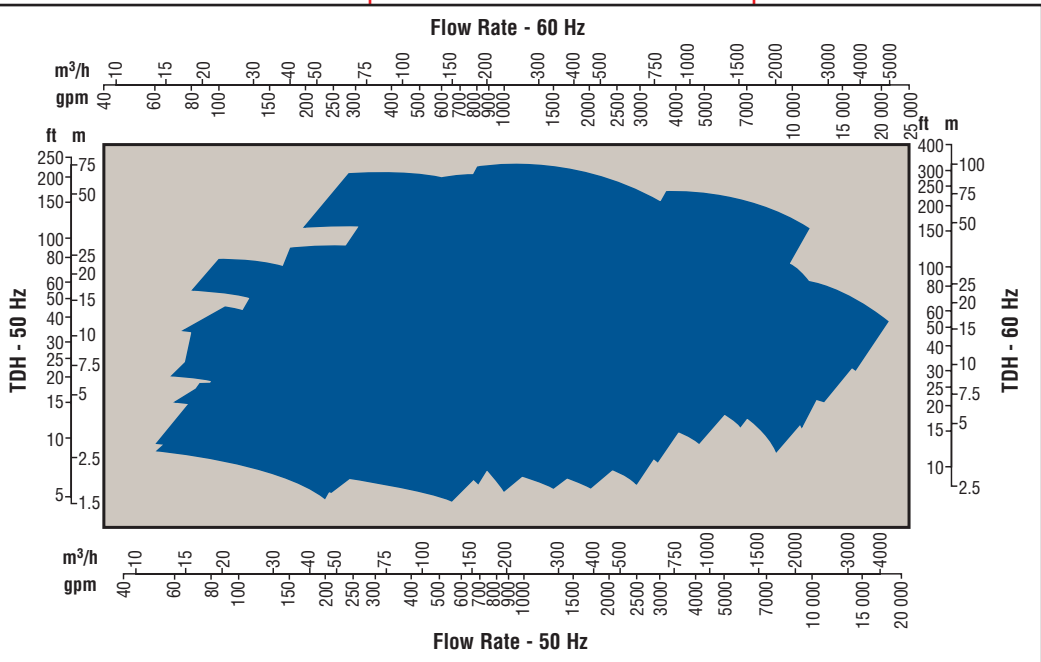

**Global
Engineered Services
and Support**

- Total Cost Reduction*
- Asset Management*
- Product Life Cycle*
- Performance Re-rates*
- Site Diagnostics*
- Repair Services*
- Energy Management*
- Spare Parts*
- Maintenance Contracts*
- Materials Upgrades*
- Turnkey Services*
- Field Repairs*
- Installation*
- Project Supervision*
- Commissioning*
- Equipment Upgrades*
- Condition Monitoring*
- Systems Analysis*
- Field Machining*

Service Dedication

Flowserve Engineered Services is focused on providing customers with uncompromising service and support, where and when needed. Dedicated to delivering the highest quality support, Engineered Services integrates its extensive pump and materials engineering knowledge with creative service solutions. Engineered Services fully understands the business challenges facing customers and is prepared to manage solutions to succeed as a team.

A worldwide network of service and repair centers staffed by highly skilled engineers and technicians is available around the clock, seven days a week to respond to customer queries, evaluate and troubleshoot problems and provide reliable solutions.



**Strength of Experience,
Commitment to Excellence**

Flowserve has long served industries requiring superior equipment performance and service life.

- Oil and gas production
- Hydrocarbon processing
- Chemical processing
- Water resources
- Power generation
- Nuclear
- Mining and mineral processing
- Pulp and paper
- General industry

Engineered Services is dedicated to maximizing equipment performance and providing reliability-centered maintenance programs for pumps and related equipment, regardless of manufacturer. Using the FlowStar™ asset management software, Engineered Services tracks performance and supports improvement programs using a service life cycle cost business approach. The results are improved reliability and increased profitability.

Business Partner

Flowserve partners with customers to respond to the dynamic business conditions that affect them. Flowserve will work with customers to drive efficiency, maximize throughput and control process quality. Whether user needs involve on-site technical assistance or broader project planning with full turnkey responsibility, Flowserve Engineered Services will deliver professional, reliable results.

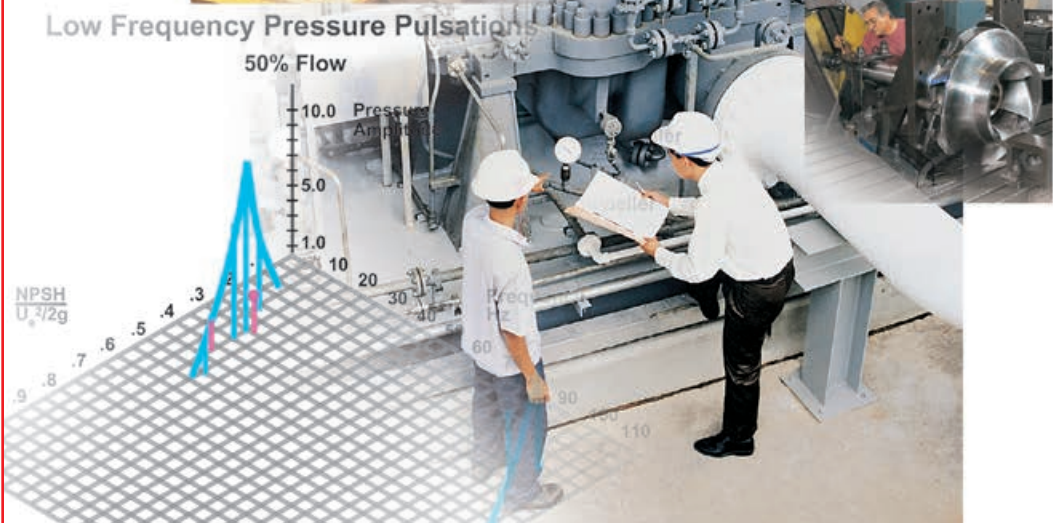
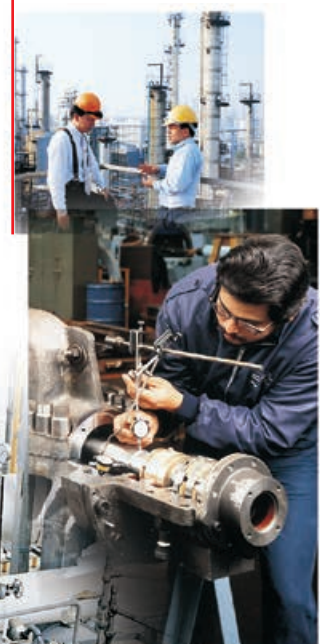

**Flowserve... Supporting Our Customers
With The World's Leading
Pump Brands**



USA and Canada

Flowserve Corporation
5215 North O'Connor Blvd.
Suite 2300
Irving, Texas 75039-5421 USA
Telephone: +1 937 890 5839

Europe, Middle East, Africa

Flowserve Corporation
Parallelweg 13
4878 AH Etten-Leur
The Netherlands
Telephone: +31 76 502 8100



Latin America

Flowserve Corporation
Martín Rodríguez 4460
B1644CGN-Victoria-San Fernando
Buenos Aires, Argentina
Telephone: +54 11 4006 8700
Telefax: +54 11 4714 1610

Asia Pacific

Flowserve Pte. Ltd.
10 Tuas Loop
Singapore 637345
Telephone: +65 6771 0600
Telefax: +65 6862 2329

Your local Flowserve representative:

**To find your local Flowserve representative,
please use the Sales Support Locator System
found at www.flowserve.com
or call: +1 937 890 5839.**