



Pump Division



**Types: MNF and MNC**  
(Vertical Close Coupled)

## **CENTRIFUGAL PUMPS**

---

***USER INSTRUCTIONS:  
INSTALLATION, OPERATION, MAINTENANCE***

PCN = 71569190 11 - 04 (E) (incorporating MNF/MNC.IOM)



*These instructions should be read prior to installing  
operating, using and maintaining this equipment.*

**CONTENTS**

	PAGE		PAGE
<b>CONTENTS</b> .....	<b>2</b>	6.7 Disassembly .....	36
<b>1 INTRODUCTION AND SAFETY</b> .....	<b>3</b>	6.8 Examination of parts.....	38
1.1 General .....	3	6.9 Assembly .....	39
1.2 CE marking and approvals.....	3	<b>7 FAULTS; CAUSES AND REMEDIES</b> .....	<b>40</b>
1.3 Disclaimer .....	3	<b>8 PARTS LIST AND DRAWINGS</b> .....	<b>42</b>
1.4 Copyright.....	3	8.1 MNF cross section and parts list .....	42
1.5 Duty conditions .....	3	8.2 MNC cross section and parts list.....	44
1.6 Safety .....	4	<b>9 CERTIFICATION</b> .....	<b>45</b>
1.7 Nameplate and warning labels .....	8	<b>10 OTHER RELEVANT DOCUMENTATION AND</b>	
1.8 Noise level .....	9	<b>MANUALS</b> .....	<b>45</b>
1.9 Specific machine performance.....	10	10.1 Supplementary user instructions .....	45
<b>2 TRANSPORT AND STORAGE</b> .....	<b>10</b>	10.2 Change notes .....	45
2.1 Consignment receipt and unpacking .....	10		
2.2 Handling.....	10		
2.3 Lifting.....	10		
2.4 Storage.....	11		
2.5 Recycling and end of product life.....	12		
<b>3 DESCRIPTION</b> .....	<b>12</b>		
3.1 Nozzle configurations.....	13		
3.2 Name nomenclature.....	13		
3.3 Design of major parts .....	13		
3.4 Performance and operating limits .....	14		
<b>4 INSTALLATION</b> .....	<b>15</b>		
4.1 Location .....	15		
4.2 Part assemblies .....	15		
4.3 Foundation .....	16		
4.4 Grouting .....	16		
4.5 Initial alignment.....	17		
4.6 Piping .....	18		
4.7 Electrical connections .....	20		
4.8 Final shaft alignment check .....	21		
4.9 Protection systems.....	21		
<b>5 COMMISSIONING, START-UP, OPERATION AND</b>			
<b>SHUTDOWN</b> .....	<b>21</b>		
5.1 Pre-commissioning procedure .....	21		
5.2 Pump Lubrication .....	21		
5.3 Impeller clearance.....	23		
5.4 Direction of rotation.....	23		
5.5 Guarding .....	24		
5.6 Priming and auxiliary supplies .....	24		
5.7 Starting the pump.....	24		
5.8 Running or operation .....	25		
5.9 Stopping and shutdown.....	27		
5.10 Hydraulic, mechanical and electrical duty... 27			
<b>6 MAINTENANCE</b> .....	<b>27</b>		
6.1 Maintenance schedule.....	28		
6.2 Spare parts.....	34		
6.3 Suggested spares and consumable items.... 35			
6.4 Tools required .....	35		
6.5 Fastener torques.....	35		
6.6 Renewal clearances.....	35		
		<b>INDEX</b>	
			<b>PAGE</b>
		Alignment of shafting (see 4.3, 4.5 and 4.7)	
		CE marking and approvals (1.2) .....	3
		Clearances (see 6.6, Renewal clearances) .....	35
		Commissioning and operation (see 5) .....	21
		Configurations (3.1).....	13
		Direction of rotation (5.4).....	23
		Dismantling (see 6.7, Disassembly).....	36
		Duty conditions (1.5) .....	3
		Electrical connections (4.7).....	20
		Examination of parts (6.8).....	38
		Faults; causes and remedies (7.0).....	40
		General assembly drawings (see 8) .....	42
		Grouting (4.4) .....	16
		Guarding (5.5) .....	24
		Handling (2.2).....	10
		Hydraulic, mechanical and electrical duty (5.10) .... 27	
		Lifting (2.3) .....	10
		Location (4.1) .....	15
		Lubrication schedule (see 5.2, Pump lubricants) .... 21	
		Maintenance schedule (6.1).....	27
		Piping (4.6) .....	18
		Priming and auxiliary supplies (5.6) .....	24
		Reassembly (see 6.9, Assembly) .....	39
		Replacement parts (see 6.3 and 6.4).....	35
		Safety, protection systems (see 1.6 and 4.9)	
		Sound level (see 1.8, Noise level) .....	9
		Specific machine performance (1.9) .....	10
		Starting the pump (5.7) .....	24
		Stopping and shutdown (5.9) .....	27
		Storage (2.4) .....	11
		Supplementary user instructions (10.1) .....	45
		Tools required (6.4).....	35
		Torques for fasteners (6.5) .....	35

## 1 INTRODUCTION AND SAFETY

### 1.1 General



***These instructions must always be kept close to the product's operating location or directly with the product.***

Flowserve's products are designed, developed, and manufactured with state-of-the-art technologies in modern facilities. The unit is produced with great care and commitment to continuous quality control, utilizing sophisticated quality techniques, and safety requirements.

Flowserve is committed to continuous quality improvement and being at service for any further information about the product in its installation and operation or about its support products, repair and diagnostic services.

These instructions are intended to facilitate familiarization with the product and its permitted use. Operating the product in compliance with these instructions is important to help ensure reliability in service and avoid risks. The instructions may not take into account local regulations; ensure such regulations are observed by all, including those installing the product. Always coordinate repair activity with operations personnel, and follow all plant safety requirements and applicable safety and health laws and regulations.



***These instructions should be read prior to installing, operating, using and maintaining the equipment in any region worldwide. The equipment must not be put into service until all the conditions relating to safety noted in the instructions, have been met.***

### 1.2 CE marking and approvals

It is a legal requirement that machinery and equipment put into service within certain regions of the world shall conform with the applicable CE Marking Directives covering Machinery and, where applicable, Low Voltage Equipment, Electromagnetic Compatibility (EMC), Pressure Equipment Directive (PED) and Equipment for Potentially Explosive Atmospheres (ATEX).

Where applicable the Directives and any additional Approvals cover important safety aspects relating to machinery and equipment and the satisfactory provision of technical documents and safety instructions. Where applicable this document incorporates information relevant to these Directives

and Approvals. To confirm the Approvals applying and if the product is CE marked, check the serial number plate markings and the Certification. (See section 9, *Certification*.)

### 1.3 Disclaimer

***Information in these User Instructions is believed to be reliable. In spite of all the efforts of Flowserve Pump Division to provide sound and all necessary information the content of this manual may appear insufficient and is not guaranteed by Flowserve as to its completeness or accuracy.***

Flowserve manufactures products to exacting International Quality Management System Standards as certified and audited by external Quality Assurance organizations. Genuine parts and accessories have been designed, tested, and incorporated into the products to help ensure their continued product quality and performance in use. As Flowserve cannot test parts and accessories sourced from other vendors the incorrect incorporation of such parts and accessories may adversely affect the performance and safety features of the products. The failure to properly select, install, or use authorized Flowserve parts and accessories is considered to be misuse. Damage or failure caused by misuse is not covered by Flowserve's warranty. In addition, any modification of Flowserve products or removal of original components may impair the safety of these products in their use.

### 1.4 Copyright

All rights reserved. No part of these instructions may be reproduced, stored in a retrieval system or transmitted in any form or by any means without prior permission of Flowserve Pump Division.

### 1.5 Duty conditions

This product has been selected to meet the specifications of your purchaser order. The acknowledgement of these conditions has been sent separately to the Purchaser. A copy should be kept with these instructions.



***The product must not be operated beyond the parameters specified for the application. If there is any doubt as to the suitability of the product for the application intended, contact Flowserve for advice, quoting the serial number.***

If the conditions of service on your purchase order are going to be changed (for example liquid pumped, temperature or duty) it is requested that the user seeks Flowserve's written agreement before start up.

## 1.6 Safety

### 1.6.1 Summary of safety markings

These User Instructions contain specific safety markings where non-observance of an instruction would cause hazards. The specific safety markings are:

 **DANGER** This symbol indicates electrical safety instructions where non-compliance will involve a high risk to personal safety or the loss of life.

 This symbol indicates safety instructions where non-compliance would affect personal safety and could result in loss of life.

 This symbol indicates "hazardous and toxic fluid" safety instructions where non-compliance would affect personal safety and could result in loss of life.

 **CAUTION** This symbol indicates safety instructions where non-compliance will involve some risk to safe operation and personal safety and would damage the equipment or property.

 This symbol indicates explosive atmosphere zone marking according to ATEX. It is used in safety instructions where non-compliance in the hazardous area would cause the risk of an explosion.

**Note:** This sign is not a safety symbol but indicates an important instruction in the assembly process.

### 1.6.2 Personnel qualification and training

All personnel involved in the operation, installation, inspection and maintenance of the unit must be qualified to carry out the work involved. If the personnel in question do not already possess the necessary knowledge and skill, appropriate training and instruction must be provided.

If required the operator may commission the manufacturer/supplier to provide applicable training.

Always coordinate repair activity with operations and health and safety personnel, and follow all plant safety requirements and applicable safety and health laws and regulations.

### 1.6.3 Safety action

***This is a summary of conditions and actions to prevent injury to personnel and damage to the environment and to equipment. For products used in potentially explosive atmospheres section 1.6.4 also applies.***

 **DANGER** NEVER DO MAINTENANCE WORK WHEN THE UNIT IS CONNECTED TO POWER

 GUARDS MUST NOT BE REMOVED WHILE THE PUMP IS OPERATIONAL

 DRAIN THE PUMP AND ISOLATE PIPEWORK BEFORE DISMANTLING THE PUMP  
The appropriate safety precautions should be taken where the pumped liquids are hazardous.

 **FLUORO-ELASTOMERS** (When fitted.)  
When a pump has experienced temperatures over 250 °C (482 °F), partial decomposition of fluoro-elastomers (example: Viton) will occur. In this condition these are extremely dangerous and skin contact must be avoided.

 **HANDLING COMPONENTS**  
Many precision parts have sharp corners and the wearing of appropriate safety gloves and equipment is required when handling these components. To lift heavy pieces above 25 kg (55 lb) use a crane appropriate for the mass and in accordance with current local regulations.

 **THERMAL SHOCK**  
Rapid changes in the temperature of the liquid within the pump can cause thermal shock, which can result in damage or breakage of components and should be avoided.

 **APPLYING HEAT TO REMOVE IMPELLER**  
There may be occasions when the impeller has either been shrunk fit onto the pump shaft or has become difficult to remove due to products that are corrosive in nature.

If you elect to use heat to remove the impeller, it must be applied with a great care and before applying heat ensure any residual hazardous liquid trapped between the impeller and pump shaft is thoroughly drained out through the impeller keyway to prevent an explosion or emission of toxic vapor.

Impeller design vary and so are the heat, applying location and the duration of heat application. Contact your nearest Flowserve service center for help.

**HOT (and cold) PARTS**

If hot or freezing components or auxiliary heating supplies can present a danger to operators and persons entering the immediate area action must be taken to avoid accidental contact. If complete protection is not possible, the machine access must be limited to maintenance staff only, with clear visual warnings and indicators to those entering the immediate area.

**Note:**

Bearing housings must not be insulated to avoid drive motor and bearing heat up.

***If the temperature is greater than 68 °C (175 °F) or below 5 °C (20 °F) in a restricted zone, or exceeds local regulations, action as above shall be taken.***

**HAZARDOUS LIQUIDS**

When the pump is handling hazardous liquids care must be taken to avoid exposure to the liquid by appropriate siting of the pump, limiting personnel access and by operator training. If the liquid is flammable and/or explosive, strict safety procedures must be applied.

***Gland packing must not be used when pumping hazardous liquids.***

**CAUTION**
**PREVENT EXCESSIVE EXTERNAL PIPE LOAD**

Do not use pump as a support for piping. Do not mount expansion joints, unless allowed by Flowserve in writing, so that their force, due to internal pressure, acts on the pump flange.

**CAUTION**

**ENSURE CORRECT LUBRICATION**  
(See section 5, *Commissioning, start-up, operation and shutdown.*)

**CAUTION**

**START THE PUMP WITH OUTLET VALVE PARTLY OPENED**  
(Unless otherwise instructed at a specific point in the User Instructions.)

This is recommended to minimize the risk of overloading and damaging the pump motor at full or zero flow. Pumps may be started with the valve further open only on installations where this situation cannot occur. The pump outlet control valve may need to be adjusted to comply with the duty following the run-up process. (See section 5, *Commissioning start-up, operation and shutdown.*)

**CAUTION**

**NEVER RUN THE PUMP DRY**

**CAUTION**
**INLET VALVES TO BE FULLY OPEN WHEN PUMP IS RUNNING**

Running the pump at zero flow or below the recommended minimum flow continuously will cause damage to the seal.

**CAUTION**

**DO NOT RUN THE PUMP AT ABNORMALLY HIGH OR LOW FLOW RATES**  
Operating at a flow rate higher than normal or at a flow rate with no backpressure on the pump may overload the motor and cause cavitation. Low flow rates may cause a reduction in pump/bearing life, overheating of the pump, instability and cavitation/vibration.

**1.6.4 Products used in potentially explosive atmospheres**

Measures are required to:

- Avoid excess temperature
- Prevent build up of explosive mixtures
- Prevent the generation of sparks
- Prevent leakages
- Maintain the pump to avoid hazard

The following instructions for pumps and pump units when installed in potentially explosive atmospheres must be followed to help ensure explosion protection. Both electrical and non-electrical equipment must meet the requirements of European Directive 94/9/EC.

**1.6.4.1 Scope of compliance**



Use equipment only in the zone for which it is appropriate. Always check that the driver, drive coupling assembly, seal and pump equipment are suitably rated and/or certified for the classification of the specific atmosphere in which they are to be installed.

Where Flowserve has supplied only the bare shaft pump, the Ex rating applies only to the pump. The party responsible for assembling the pump set shall select the coupling, driver and any additional equipment, with the necessary CE Certificate/ Declaration of Conformity establishing it is suitable for the area in which it is to be installed.

The output from a variable frequency drive (VFD) can cause additional heating affects in the motor and the ATEX Certification for the motor must state that it is covers the situation where electrical supply is from the VFD. This particular requirement still applies even if the VFD is in a safe area.

### 1.6.4.2 Marking

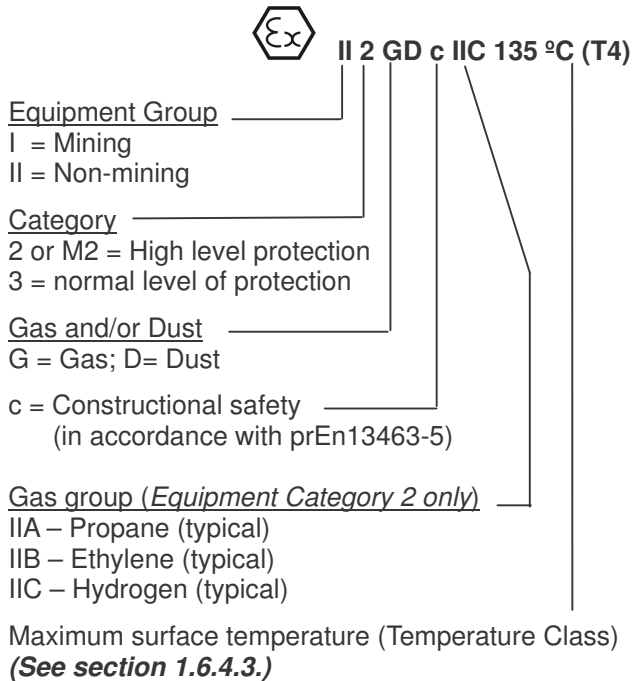
An example of ATEX equipment marking is shown below. The actual classification of the pump will be engraved on the nameplate.



### 1.6.4.3 Avoiding excessive surface temperatures

ENSURE THE EQUIPMENT TEMPERATURE CLASS IS SUITABLE FOR THE HAZARD ZONE

Pumps have a temperature class as stated in the ATEX Ex rating on the nameplate. These are based on a maximum ambient of 40 °C (104 °F); refer to Flowserve for higher ambient temperatures.

The surface temperature on the pump is influenced by the temperature of the liquid handled. The maximum permissible liquid temperature depends on the temperature class and must not exceed the values in the table that follows.

The temperature rise at the seals and bearings and due to the minimum permitted flow rate is taken into account in the temperatures stated.

Temperature class to prEN 13464-5	Maximum surface temperature permitted	Temperature limit of liquid handled (* depending on material and construction variant - check which is lower)
T6	85 °C (185 °F)	Consult Flowserve
T5	100 °C (212 °F)	Consult Flowserve
T4	135 °C (275 °F)	115 °C (239 °F) *
T3	200 °C (392 °F)	180 °C (356 °F) *
T2	300 °C (572 °F)	275 °C (527 °F) *
T1	450 °C (842 °F)	400 °C (752 °F) *

**The responsibility for compliance with the specified maximum liquid temperature is with the plant operator.**

**Note:**

Temperature classification “Tx” is used when the liquid temperature varies and the pump could be installed in different hazardous atmospheres. In this case the user is responsible for ensuring that the pump surface temperature does not exceed that permitted in the particular hazardous atmosphere.

If an explosive atmosphere exists during the installation, do not attempt to check the direction of rotation by starting the pump unfilled. Even a short run time may give a high temperature resulting from contact between rotating and stationary components.

Wherever there is any risk of the pump being run against a closed valve generating high liquid and casing external surface temperatures, it is recommended that users fit an external surface temperature protection device.

Avoid mechanical, hydraulic or electrical overload by using motor overload trips, temperature monitor or a power monitor and make routine vibration monitoring checks.

In dirty or dusty environments, regular checks must be made and dirt removed from areas around close clearances, bearing housings and motors.

### 1.6.4.4 Preventing the build up of explosive mixtures

ENSURE THE PUMP IS PROPERLY FILLED AND VENTED AND DOES NOT RUN DRY

Ensure the pump and relevant suction and discharge pipeline system is totally filled with liquid at all times during the pump operation, so that an explosive atmosphere is prevented. In addition it is essential to make sure that seal chambers, auxiliary shaft seal systems and any heating and cooling systems are properly filled.

If the operation of the system cannot avoid this condition, fitting of an appropriate dry run protection device is recommended.

To avoid potential hazards from fugitive emissions of vapor or gas to atmosphere, the surrounding area must be well ventilated.

#### 1.6.4.5 Preventing sparks



To prevent a potential hazard from mechanical contact, the coupling guard must be non-sparking and anti-static for Category 2.

To avoid the potential hazard from random induced current generating a spark, the earth contact on the baseplate must be used.

Avoid electrostatic charge: do not rub non-metallic surfaces with a dry cloth; ensure cloth is damp.

The coupling must be selected to comply with 94/9/EC and correct alignment must be maintained.

#### 1.6.4.6 Preventing leakage



The pump must only be used to handle liquids for which it has been approved to have the correct corrosion resistance.

Avoid entrapment of liquid in the pump and associated piping due to closing of suction and discharge valves, which could cause dangerous excessive pressures to occur if there is heat input to the liquid. This can occur if the pump is stationary or running.

Bursting of liquid containing parts due to freezing must be avoided by draining or protecting the pump and ancillary systems.

Where there is the potential hazard of a loss of a seal barrier fluid or external flush, the fluid must be monitored.

If leakage of liquid to atmosphere can result in a hazard, the installation of a liquid detection device is recommended.

#### 1.6.4.7 Maintenance to avoid the hazard



CORRECT MAINTENANCE IS REQUIRED TO AVOID POTENTIAL HAZARDS WHICH GIVE A RISK OF EXPLOSION

***The responsibility for compliance with maintenance instructions is with the plant operator.***

To avoid potential explosion hazards during maintenance, the tools, cleaning and painting materials used must not give rise to sparking or adversely affect the ambient conditions. Where there is a risk from such tools or materials, maintenance must be conducted in a safe area.

It is recommended that a maintenance plan and schedule is adopted to include the following. (See section 6, *Maintenance*.)

- a) Any auxillary systems installed must be monitored, to ensure they function correctly.
- b) Gland packings must be adjusted correctly to give visible leakage and concentric alignment of the gland follower to prevent excessive temperature of the packing or the follower.
- c) Check for any leaks from gaskets and seals. The correct functioning of the shaft seal must be checked regularly.
- d) Chck bearing lubricant level, and verify if the hours run show a lubricant change is required.
- e) Check the duty condition is in the safe operating range for the pump.
- f) Check vibration, noise level and surface temperature at the bearings to confirm satisfactory operation.
- g) Check that dirt and dust are removed from areas around close clearances, bearing housings and motors.
- h) Check coupling alignment and re-align if necessary.

## 1.7 Nameplate and warning labels

### 1.7.1 Nameplate

For details of nameplate, see the Declaration of Conformity /Flowserve documentation provided or contact Flowserve for help.

### 1.7.2 Warning labels

<b>FLOWSERVE</b>		<b>WARNING</b>	J218JZ250
ESSENTIAL PROCEDURES BEFORE STARTING:			
	INSTALL AND OPERATE EQUIPMENT IN ACCORDANCE WITH THE INSTRUCTION MANUAL SUPPLIED SEPARATELY.		ENSURE ALL EXTERNAL CONNECTIONS TO THE PUMP / SHAFT SEALING AND DRIVER ARE CONNECTED AND OPERATIONAL.
	ENSURE GUARDS ARE SECURELY IN PLACE.		FULLY PRIME UNIT AND SYSTEM. DO NOT RUN UNIT DRY.
	ENSURE CORRECT DIRECTION OF ROTATION.		FAILURE TO FOLLOW THESE PROCEDURES MAY RESULT IN PERSONAL INJURY AND / OR EQUIPMENT DAMAGE

		J218/268
	<p>ENSURE UNIT ON A FIRM FOUNDATION AND THAT COUPLING FACES ARE IN CORRECT ALIGNMENT PRIOR TO AND AFTER BOLTING BASEPLATE DOWN AND FIXING PIPEWORK. SEE MANUAL FOR TOLERANCES.</p> <p>S'ASSURER QUE LE GROUPE ELECTROPOMPE EST FERMEMENT INSTALLE SUR SON MASSIF. VERIFIER LE LIGNAGE DE L'ACCOUPEMENT AVANT ET APRES FIXATION DU SOCLE ET DE LA TUYAUTERIE. <u>VOIR LES TOLERANCES D'ALIGNMENT SUR LA NOTICE</u></p>	<p>PUMP MUSS AUF FESTEM FUNDAMENT STEHEN. KUPPLUNGSHÄLFTEN <u>KORREKT AXIAL AUSRICHTEN</u>. DANN PUMPE AUF GRUNDPLATTE FESTSPANNEN UND ANSSCHLUSSLEITUNGEN BEFESTIGEN. TOLERANZEN S. BEDIEUNGSANLEITUNG.</p> <p>ZORG DAT POMPEENHEID OP EEN STEVIGE ONDERGROND OPGESTELD STAAT EN DAT KOPPELING CORRECT UITGELIJT IS ZOWEL VOOR-ALS NADAT DE GRONDPLAAT MET BOUTEN IS VASTGEZET EN DE LEIDINGEN GEINSTALLEERD ZIJN. ZIE HANDLEIDING VOOR TOELAABARE SPELINGEN.</p>
CDC: 603 604 610 612 621 623 624		

### Oil lubricated units only

		J218JZ262
	<p>WARNING ATTENTION</p>	<p>THIS MACHINE MUST BE FILLED WITH OIL BEFORE STARTING CETTE MACHINE DOIT ÊTRE REMPLIE D'HUILE AVANT LA MISE EN MARCHÉ</p>
	<p>ACHTUNG WAARSCHUWING</p>	<p>DIESE MASCHINE IST VOR DEM STARTEN MIT ÖL ZÜ FULLEN DEZE MACHINE MOET VOOR HET STARTEN MET OLIE GEVULD WORDEN</p>
CDC: 603 604 610 612 621 623 624		



## 1.8 Noise level

Whenever pump noise level exceeds 85 dBA, attention must be given to prevailing Health and Safety Legislation, to limit the exposure of plant operating personnel to the noise. Typical safety level requires to limit the sound level of 90 dBA for 8 hours of exposure and the allowable dBA value increases 5 dBA for each halving of exposure time. The usual approach is to control exposure time to the noise or to enclose the machine to reduce emitted sound.

You may have already specified a limiting noise level when the equipment was ordered, however if no noise requirements were defined then machines above a certain power level will exceed 85 dBA. In such situations, consideration must be given to the fitting of an acoustic enclosure to meet local regulations.

### 1.8.1 Typical sound levels for MNF & MNC pumps

Typical sound pressure levels measured in dB, and are A-weighted.

Motor Frame Size. NEMA	RPM	Motor Only Sound Pressure (dBA )	Pump only Sound Pressure (dBA )	Combination of pump and motor Sound pressure (dBA)
180	1800	60.0	65	70
	1200 & slower	55.0	55	63
210	1800	60.0	65	69
	1200 & slower	55.0	56	63
250	1800	70.0	77	77
	1200 & slower	60.0	68	69
280	1800	70.0	77	77
	1200 & slower	60.0	68	69
320	1800	65.0	77	77
	1200 & slower	65.0	69	69
360	1800	65.0	77	78
	1200 & slower	65.0	68	69
400	1800	70.0	77	78
	1200 & slower	65.0	68	69
440	1800	70.0	77	78
	1200 & slower	65	68	69

*Sound pressure values indicated for the motor are extracted from typical motor manufacturer's data at no load conditions and are not guaranteed. They may vary depending on the type of motor, enclosure used, and the manufacturer. The sound pressure values for the pump are estimated levels in free field measured 1 meter from the nearest major pump surface and at a height of 1.5 meters above the floor. using speed, flow rate, motor horsepower, number of impeller vanes, and other variables. Therefore values indicated are for reference only and could exceed the estimated values by as much as 8~10 dBA depending upon factors such as installed conditions, building acoustics, foundation, piping, operating conditions, surrounding machinery. It is highly recommended to take actual field measurement of sound pressure values, apply enclosures and safety measures mandated by the local authorities and prevailing safety regulations. For all other pump and motor frame size combinations, the sound levels have to be measured and safety measures have to be adopted.*



For units driven by equipment other than electric motors or units contained within enclosures, see the accompanying information sheets and manuals.

### 1.9 Specific machine performance

For performance parameters see section 1.5, *Duty conditions*. When the contract requirement specifies these to be incorporated into User Instructions these are included here. In cases where performance data has been supplied separately to the purchaser these should be obtained and retained with these User Instructions, if required.

## 2 TRANSPORT AND STORAGE

### 2.1 Consignment receipt and unpacking

Immediately after receipt of the equipment it must be checked against the delivery and shipping documents for its completeness and that there has been no damage in transportation.

Any shortage and or damage must be reported immediately to Flowserve Pump Division and must be received in writing within one month of receipt of the equipment. Claims made later than this specified time period will not be accepted.

Check any crate, boxes, and wrappings for any accessories or spare parts that may be packed separately with the equipment or attached to sidewalls of the box or equipment.

Each product has a unique serial number. Check that this number corresponds with that advised and always quote this number in correspondence as well as when ordering spare parts or further accessories.

### 2.2 Handling

Boxes, crates, pallets or cartons may be unloaded using forklift vehicles or slings dependent on their size and construction.

### 2.3 Lifting

To avoid distortion, the pump unit should be lifted as shown in sections 2.3.1.

It is strongly recommended to lift the pump using appropriate equipments and proven procedures. It is strongly recommended to employ experts for the task to avoid injury or loss of life.

A crane must be used for all pump sets in excess of 25 kg (55 lb). Fully trained personnel must carry out lifting, in accordance with local regulations.

#### 2.3.1 Lifting of pump together with the motor base and suction nozzle/elbow

Do not lift the pump with motor attached.

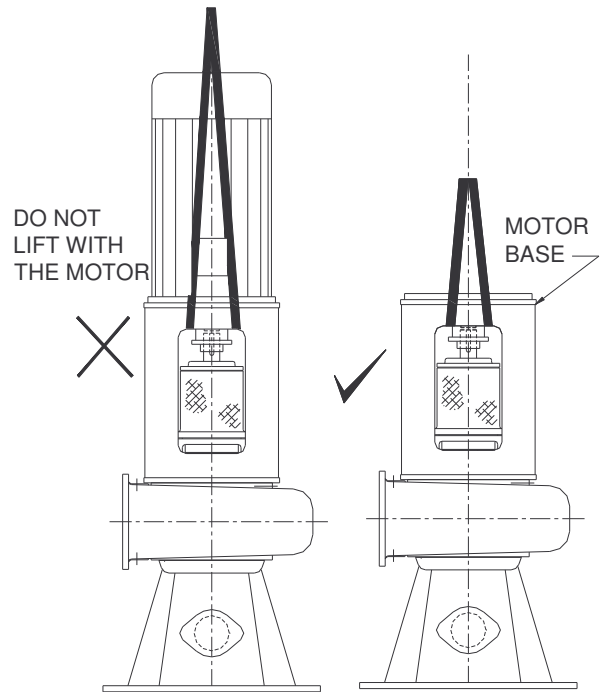

**MNF**

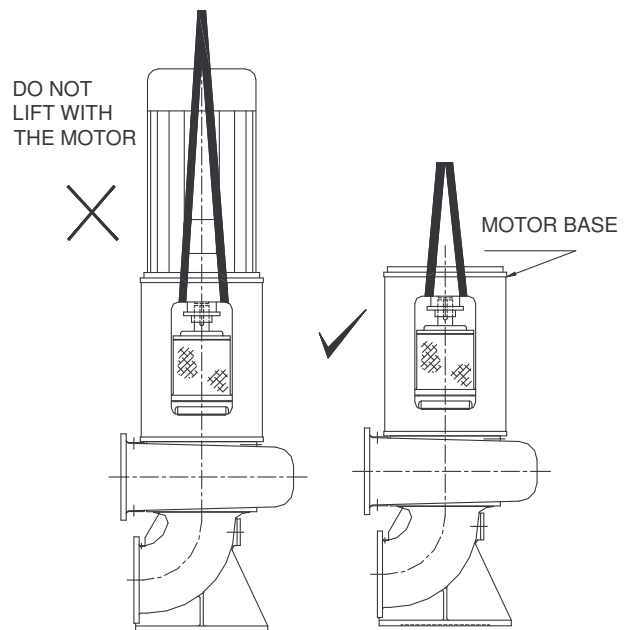

**MNC**

Use stuffing box head and /or lifting eyes (if provided) on the casing for lifting. Make sure to balance the weight such that there is no tilting to any one side.

### 2.3.2 Lifting of driver

Use driver lifting lugs/ or follow driver manufacturer's User Instructions.



A crane must be used for all pump sets in excess of 25 kg (55 lb). Fully trained personnel must carry out lifting, in accordance with local regulations. The driver and pump weights to be noted before lifting is attempted.

## 2.4 Storage



Store the pump in a clean, dry location away from vibration. Leave piping connection covers in place to keep dirt and other foreign material out of pump casing. Turn pump at intervals to prevent brinelling of the bearings and the seal faces (if fitted), from sticking.

### 2.4.1 Inspection before storage

- Inspect the preservative coating/painted surfaces on the various parts. Touch up wherever necessary.
- Inspect all covers over pump openings and piping connections. If found damaged, remove the covers and inspect interiors of the opening for any deposits of foreign materials or water.
- If necessary, clean and preserve the interior parts as noted above to restore the parts to the "as shipped" condition. Replace covers and fasten securely.

### 2.4.2 Short term storage (less than 6 months)

When it is necessary to store a pump for a short time before it can be installed, place it in a dry location and protect it thoroughly from moisture.

When protective flanges are bolted to the suction and discharge nozzles at the factory, they should not be removed. Protect the bearings and the shaft against moisture, dirt, or other foreign matter. To prevent rusting in or seizing, lubricate the unit; see Section 5.2, *Pump Lubricants*. Rotate the pump shaft a minimum of 5 revolutions every two weeks to keep the bearings coated with lubricant and to minimize the effects of brinelling.



MNF and MNC standard pumps are grease lubricated. Oil lubricated anti-friction bearings are factory lubricated to prevent rusting for a short period of time only. It is important to fill the recommended oil lubricant to proper level immediately upon receiving the equipment.

### 2.4.3 Long term storage (6 months and over)

#### Note:

More thorough precautions are required if the pump is scheduled to be stored for an extended period of time. Contact Flowserve before long-term storage is attempted for specific storage requirements and warranty information.

The following is a general procedure and could vary depending upon the pump design and specific application.



The storage area should be a clean and dry. The storage location not be subjected to rapid changes in temperature, light (no direct lighting) or humidity, and relatively free of ground transmitted vibration due to heavy construction and/or machinery.

A temperature range of 5 ° to 50 °C ( 40 ° to 120° F) with non-condensing humidity is recommended.

- Drain fluid from the pump, rotate the pump rotor once in the proper direction and blow the liquid end dry with air.
- Coat the interior surfaces of the liquid end with rust inhibitor by brushing, spraying or fogging. Rotate the pump shaft one turn in the proper direction while coating.
- Remove the packing and seal cage from the stuffing box to prevent corrosion due to condensation. Coat the interior machined surfaces of stuffing box with a rust inhibitor. This step may be omitted if the pumps are stored prior to initial use.
- For grease lubricated bearing frames, fill the cavity between the bearing covers and bearings with a good grade of NGLI No. 2 lithium base grease to prevent contamination of the bearings. Ensure the bearings are thoroughly packed with grease. Lubrication quality and quantity must be checked every six months and replaced or replenished as necessary.
- Coat all threaded openings with rust inhibitor and plug. Coat machined surfaces of exposed flanges with rust inhibitor and then cover with fiberboard or wood flange covers. Desiccant bags should be secured to the covers prior to putting them in place and must not contact metal surfaces.
- Coat exposed, unpainted, and machined surfaces with a rust inhibitor.

- g) Cover openings in the stuffing box head between the casing and bearing frame with plastic, taped in place, to prevent entrance of contaminants into the stuffing box and line bearing area.
- h) Cover the entire pump with a clear plastic sheet for protection from dust, dirt moisture, etc. and to allow for visual inspection. The cover should be open near the top to allow for ventilation.
- i) Rotate the pump shaft a minimum of 5 revolutions every two weeks to keep the bearings coated with lubricant and to minimize the effects of brinelling.
- j) Refer to the vendors instruction manuals for extended storage procedure for motors, controls, coupling, etc.,
- k) Prior to start up or installation, an Flowserve representative should be hired to inspect all equipment to determine if any damage or deterioration of parts has occurred and that the equipment is in "as shipped" condition.

### 2.5 Recycling and end of product life

At the end of the service life of the product or its parts, the relevant materials and parts should be recycled or disposed of using an environmentally acceptable method and local regulations. If the product contains substances that are harmful to the environment, these should be removed and disposed of in accordance with current regulations. This also includes the liquids and or gases that may be used in the "seal system" or other utilities.



Make sure that hazardous substances are disposed of safely and that the correct personal protective equipment is used. The safety specifications must be in accordance with the current regulations at all times.

### 3 DESCRIPTION

The MNF/MNC type pumps are single stage, volute type, dry pit, centrifugal pumps designed for handling sewage, storm water, dry dock and industrial waste applications with end suction side discharge mix flow non-clog design.

It should be noted that unscreened raw sewage may introduce some chances of clogging and therefore clogging may be totally avoided, if appropriate level of screening is applied.



Shaft guards are supplied if ordered. It is the responsibility of the operators of drive shaft and universal joints to provide and install guards or safety devices, which may be required by recognized safety standards.

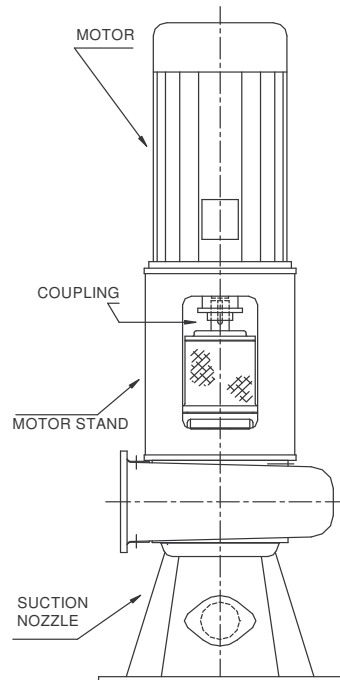

Pump type MNF (with suction nozzle)

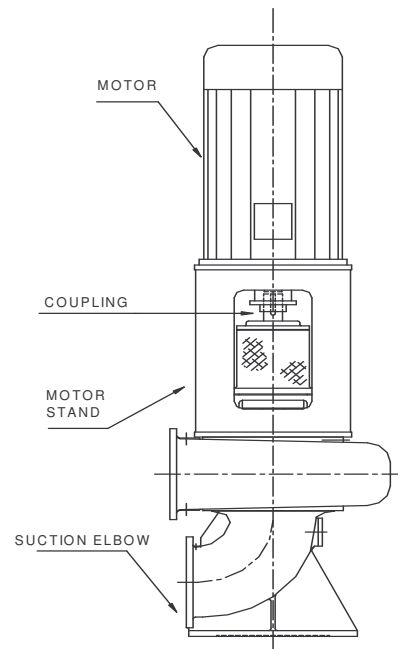

Pump type MNC (with suction elbow)

These are end suction side discharge mix flow non-clog pump. The information contained in this book covers long shafted pumps where the pump and driver are installed separately connected by one or multiple shafting using universal joints (some exceptional cases may have rigid or geared couplings). Type MNF is fitted with a suction nozzle and MNC with a suction elbow.

### 3.1 Nozzle configurations

The MNF and MNC pumps are configured with various nozzle positions, designated A-H as shown (Example: for counter clock-wise rotation).

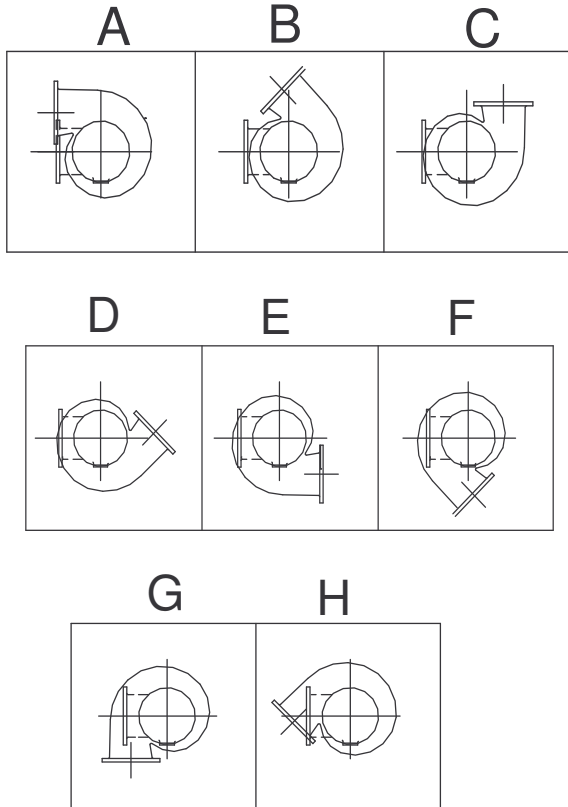

### 3.2 Name nomenclature

The pump size will be engraved on the nameplate typically as below:

**24-MNF/MNC-28**

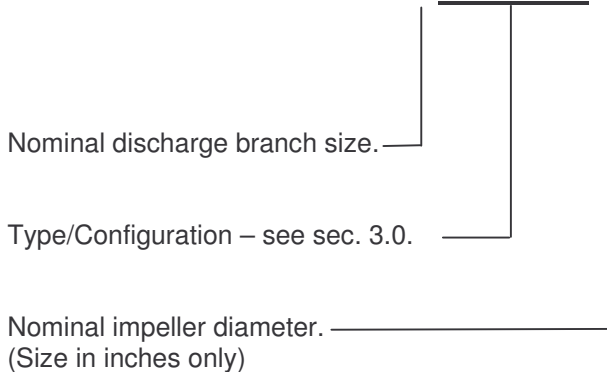

The typical nomenclature above is the general guide to the MNF/MNC configuration description. Identify the actual pump size and serial number from the pump nameplate. Check that this agrees with the applicable certification provided.

### 3.3 Design of major parts

#### 3.3.1 Pump casing & stuffing box head

The pump casing with its integrally cast discharge nozzle is of the volute type. It is machined to provide a rabbet fit for the stuffing box head and suction head. The heads are removable and are bolted to and centered in the casing. The casing and suction head are each provided with one hand hole for inspection and cleaning of the pump without dismantling. The pump has its main casing gasket axial to the shaft allowing maintenance to the rotating element by separating the impeller assembly from the casing. Suction and discharge branches remain undisturbed.

#### 3.3.2 Impeller and wearing rings

The impeller is a solids handling type capable of passing trash and solids of limited size. The impeller hub is keyed to the shaft and held in position by an impeller nut which is set screwed to the impeller to prevent its backing off. A pair of replaceable wearing rings (optional) between the rotating impeller and the stationary suction head are provided for impeller wear resistance.

##### 3.3.2.1 Impeller and wearing ring arrangement

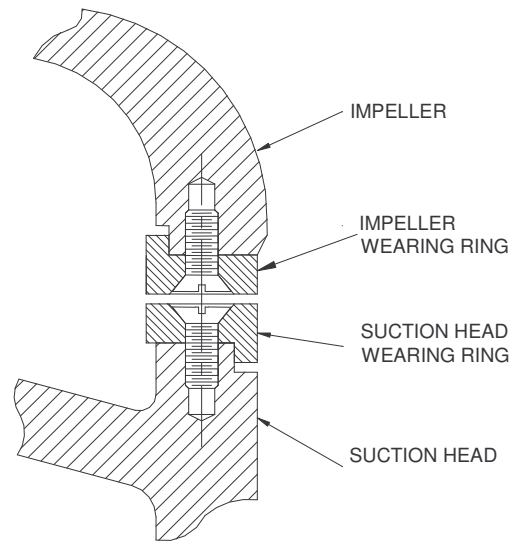

#### 3.3.3 Shaft and shaft sleeve

The pump shaft is sized to transmit the rated loads encountered with liberal safety factors, and is accurately machined over its full length. Generous fillets are used to minimize stress concentrations. It is protected from wear at the stuffing box by a removable shaft sleeve.

### 3.3.4 Pump bearings and lubrication

MNF & MNC pumps are equipped with anti-friction bearings of the tapered roller type. The line and thrust bearings are arranged in opposed mounting and can be furnished with grease as standard and custom built oil lubricated pumps.

### 3.3.5 Bearing housing

Bearings are mounted in a removable cast iron bearing frame. The frame casting offers solid support and location to the bearings and two grease nipples enable grease lubricated bearings to be replenished between major service intervals.

### 3.3.6 Stuffing box housing

The stuffing box housing cast integrally with the back head and has designed number of sealing options. For applications requiring Mechanical Seals refer to the Mechanical Seal Manufacturer's instructions.

Packing within the pump stuffing box seals the pump against leakage along the shaft at the point where it passes through the stuffing box. It should be packed with rings of braided, non-asbestos packing and a seal cage. It is equipped with a split removable packing gland.

The number of packing rings list is provided in section 6.1.8.1. Place two rings of packing below the seal cage and the remaining rings above the seal cage.

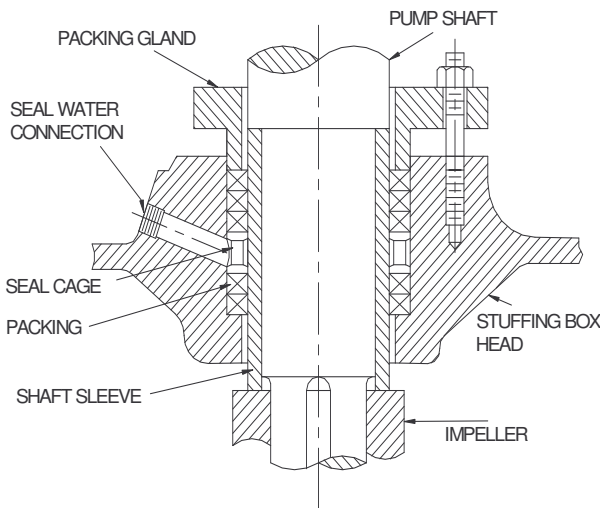

**CAUTION** The stuffing box is not packed when the pump is shipped.

A water supply of approximately 0.113 to 0.227 m<sup>3</sup>/h (0.5 to 1.0 gpm) is to be introduced to the seal water connection to provide for packing lubrication and sealing. A steady "trickle" of water from the stuffing box will indicate proper adjustment. The sealing water supply pressure should be 0.35 to 0.69 bar (5 to 10 psi) above the pump discharge pressure. When grease sealing is used, a similar grease pressure should be maintained. A slight leakage of liquid from the stuffing box is to be expected and the gland **MUST NOT** be tightened to the point of stopping the leakage.

### 3.3.7 Shaft seal

The mechanical seal(s) attached to the pump shaft seals the pumped liquid from the environment. Gland packing may be fitted as an option. See section 6.1.9 for mechanical seal maintenance information.

### 3.3.8 Driver

The driver is normally an electric motor. Different drive configurations may be fitted such as internal combustion engines, turbines, hydraulic motors etc., driving via couplings, belts, gearboxes, drive shafts. All metal flexible couplings are normally used for connecting pump and drive shafts. For operating instructions, refer to the coupling manufacturer's User Instructions.

### 3.3.9 Close coupled system

Flexible coupling is usually used with MNF/MNC pump installations. For operating instructions, refer to the coupling manufacturer's User Instructions.

### 3.3.10 Accessories

Accessories may be fitted when specified by the customer

## 3.4 Performance and operating limits

This product has been selected to meet the specifications of your purchase order. See section 1.5.

The following data is included as additional information to help with your installation. It is typical, and factors such as temperature, materials, and seal type may influence this data. If required, a definitive statement for your particular application can be obtained from Flowserve.

### 3.4.1 Operating limits

Pumped liquid temperature limits*	5 °C (40 °F) to +80 °C (176 °F)
Maximum ambient temperature*	5 °C (40 °F) to +40 °C (104 °F)
Maximum pump speed	refer to the nameplate

\*Subject to written agreement from Flowserve. Special designs and materials may be available for pumps operating above and below these specified limits. Contact Flowserve for upgrade options available for your specific application.

### 3.4.2 Pump and impeller data

Details of impeller diameter (trim), wearing ring diameter, are normally provided with the pump along with the test curve data. If not found with the pump, please contact Flowserve representative.

## 4 INSTALLATION



Equipment operated in hazardous locations must comply with the relevant explosion protection regulations. See section 1.6.4, *Products used in potentially explosive atmospheres*.

**Inspection prior to installation:** Six months prior to the scheduled installation date, a Flowserve Pump Division representative is to be employed to conduct an inspection of the equipment and the facility. If any deterioration of equipment is noticed, the Flowserve Pump Division representative may require a partial or complete dismantling of the equipment including restoration and replacement of some components.

### 4.1 Location

The pump should be located to allow room for access, ventilation, maintenance and inspection with ample headroom for lifting and should be as close as practicable to the supply of liquid to be pumped.

#### 4.1.1 General installation check-list

The following checks should be made before starting actual installation.

- Make sure that the motor nameplate ratings and the power supply system match correctly.
- Check the sump depth and suction pipe length match up.
- Check the liquid level in the sump.
- Check the installation equipment to be sure that it will safely handle the pump weight and size.
- Check all pump connections (bolts, nuts etc) for any shipping and handling related problems.
- Check for any evidence of lubricant leakage at the bearings.
- Check that the shaft rotates freely.

### 4.1.2 Cleaning prior to installation

Remove the rust inhibitor, flange protectors, plastic covers, desiccant, and inspect the inside of the pump. Repack the stuffing box and ensure that the stuffing box drain is clear. Flush the bearings using a hot, light oil at 82° to 93°C (180° to 200° F) while the shaft is slowly rotated. Re-lubricate the bearings as explained in Section 5.0

### 4.1.3 Manufacturer's service

It is recommended that the services of Flowserve Company Service Representative be employed for installing and starting the pump as proper installation is vital for designed functioning, performance and reliability of the equipment.

### 4.1.4 Site preparation

Care should be taken to prevent an out of service pump from freezing during cold weather. Draining the pump is recommended when there is any possibility of freezing.



Observe extreme caution when priming, venting and draining hazardous liquids. Wear protective clothing in the presence of hazardous, caustic, volatile, flammable and hot liquids. Do not breathe toxic vapors. Do not swallow. Do not allow sparking, flames or hot surfaces in the vicinity of the equipment.

### 4.1.5 General tools required for installation

- Mobile crane capable of hoisting and lowering the pump and/or motor.
- Sets of chains, tongs and cable slings for attaching it to the pump and motor lifting eyes.
- General purpose hand tools, pipe wrenches, end wrenches, socket set, screwdrivers, Allen wrenches, wire brush, scraper and fine emery cloth.
- Thread sealing compound designed for stainless steel and light machinery oil.

### 4.2 Part assemblies

Motors are supplied separately for MNF/MNC pumps. It is the responsibility of the installer to ensure that the motor is assembled to the pump and lined up as detailed in section 4.5. It is also the responsibility of the installer to take note of the pump and driver weights for proper handling before assembly is attempted.

### 4.3 Foundation



There are many methods of installing pump units to their foundations. The correct method depends on the size of the pump unit, its location and limitations on its noise/vibrations. Non-compliance with the provision of correct foundation and installation may lead to failure of the pump and as such, would be outside the terms of the warranty.

The foundation may consist of material that will afford permanent, rigid support to the discharge head and will absorb expected stresses that may be encountered in service.

Concrete foundations should have anchor bolts installed in sleeves that are twice the diameter of the bolt to allow alignment and has holes in the mounting plate as illustrated in the detail below.

The foundation should be of sufficient strength to absorb vibration (i.e., at least five times the weight of the pump unit) and to form a permanent, rigid support for the suction nozzle/steel frame support. This is important in maintaining the alignment of a close coupled unit. A concrete foundation on a solid base should be satisfactory.

#### 4.3.1 Pump and structural natural frequency

Pump manufacturers can calculate or determine the natural frequency of the pump assembly, including the driver. However, in a field installation, the vibrating structure comprises, in addition to the pump assembly, the foundation, the mounting, the piping, and supports. The natural frequency of the vibrating structure is determined by the stiffness of the total structure and by its equivalent mass. The natural frequency of the structure may therefore differ significantly from the natural frequency of the pump.

In the absence of any specific information, the pump manufacturer will assume that the piping is installed rigidly and anchored close to the pump connections.

It will also be assumed that the hold down bolts are securely embedded in a concrete foundation of infinite mass and rigidity.

The system designer must give proper consideration and must ensure that the natural frequency of the vibrating structure, as defined above, does not fall within the pump operating speed range. That person also must be aware of the much lower stiffness of fabricated system structures, relative to concrete, and the problems associated with calculating stiffness of unconventional and composite structures.

### 4.4 Grouting



The pump and motor must be aligned on the base prior to grouting the base in place (see alignment). To do otherwise will negate the factory pre-alignment and may result in alignment difficulties at the expense of others. Where applicable, grout in the foundation bolts.

Grouting provides solid contact between the pump unit and foundation, prevents lateral movement of running equipment and dampens resonant vibrations.

#### 4.4.1 Typical foundation bolt arrangement

Foundation bolts of the specified size should be embedded in concrete and located according to the Elevation drawing. Each bolt should be surrounded by a pipe sleeve at least two times the diameter of the bolt. The sleeve should be held rigidly yet allowing the bolts to be moved to conform to the holes in the baseplate as shown in the detail under this section.

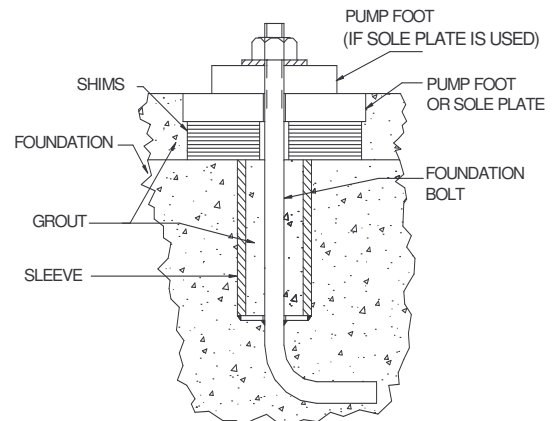

Foundation bolts should only be fully tightened when the grout has cured.

Only non-shrinking grout with a 41.4 Mpa (6000 psi) compressive strength in 72 hours should be used. Flowserve recommends the following procedure for grouting.

#### 4.4.2 Recommended procedure for grouting

- a) Build a wooden form around the outside of the base to contain the grout. In some cases the form is placed tightly against the lower edge of the base and in other cases it is placed a slight distance from the edge of the pump base.



- b) Saturate the top of the rough concrete foundation with water, if required before grouting. Add grout until the entire area under the pump base is filled, including the space between the foundation bolt and pipe sleeve. A stiff wire should be used to work the grout and release any air pockets.
- c) After the grout is poured, the exposed surfaces should be covered with wet burlap to effect slow curing and prevent cracking. When the grout is set (about 48 hours) remove the forms and smooth the exposed surfaces if desired. The grout should be allowed to cure at least 72 hours before dynamically loaded.

 If leveling nuts are used on the foundation bolts to level the base, they must be backed off as far as possible prior to grouting the base in place. Shim near the foundation bolts, back off the leveling nuts, and tighten the foundation bolts. To do otherwise will significantly lower the structural natural frequency and result in separation of the base from the grout.

## 4.5 Initial alignment

 **DANGER** Ensure pump and driver are isolated electrically and the half couplings are disconnected.

 MNF/MNC pumps are shipped from the factory without the pump or motor couplings mounted. The couplings are mounted in the field. Refer to the shafting manufacturer's instruction manual to determine the type of coupling supplied with your unit.

Mount interference fit couplings by heating them evenly in an oven to approximately 135 °C (275 °F). This is required as the coupling flanges are designed for an interference fit per AGMA Standard 9002. Do not alter this fit. Upon removal from the oven, position the hubs on the shafts, as required.

 **CAUTION** DO NOT hammer on the flanges in an attempt to remove them from the shaft. To do so will permanently damage the bearings in the pump and/or the motor. Interference fit couplings have to be removed by applying heat and a puller. The alignment must be checked after the pump is completely piped up.

### 4.5.1 Thermal expansion

 **CAUTION** The pump and motor will normally have to be aligned at ambient temperature and should be corrected to allow for thermal expansion at operating temperature. In pump installations involving high liquid temperatures, the unit should be run at the actual operating temperature, shut down and the alignment checked immediately.

### 4.5.2 Alignment methods

 **DANGER** Ensure pump and driver are isolated electrically and the couplings are disconnected.

 **CAUTION** The alignment **MUST** be checked. Although the pump will have been aligned at the factory, it is most likely that this alignment will have been disturbed during transportation or handling. If necessary, align the motor to the pump, not the pump to the motor. Alignment is achieved by adding or removing shims under the motor feet and also moving the motor horizontally as required. In some cases where the alignment cannot be achieved it will be necessary to move the pump before recommencing the above procedure.

### 4.5.3 Alignment Procedure

- a) Set the pump with its support on the foundation. Use shims to level and raise the pump in a vertical direction. Ensure that the suction and discharge flanges are level, plumb, and at the proper elevation.
- b) Grout the pedestal to the foundation and tighten the anchor bolts.
- c) Place the motor on the motor base. Move and shim beneath the motor base as necessary to ensure that:
  - The gap between the motor coupling to the pump coupling is maintained per design specifications. [1.5 mm (0.060 in.) is normal]
  - The motor coupling and pump coupling are level to one another
- d) **Check parallel alignment** of the coupling halves using a dial indicator. The dial indicator should be mounted on the driven half-coupling with the probe resting on the outer diameter of the driver coupling. Rotate the pump shaft and take readings at 90° intervals to check parallel alignment.

**Check angular alignment** of the coupling halves with a dial indicator. The dial indicator should be mounted on the driven half flange with the probe resting on the driver half coupling flange. Rotate both the driven and driver shafts together and take readings at 90° intervals. The difference between maximum and minimum dimensions is the angular misalignment.

For couplings with narrow flanges use a dial indicator as shown here to check both parallel and angular misalignment.

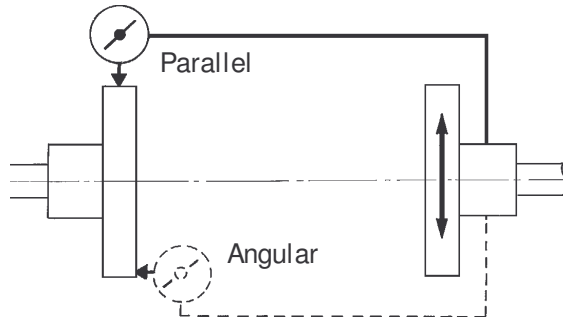

- e) Move and shim the driver until the shafts are accurately aligned.
- f) Bolt both the pump and driver, including the pump bearing frame support, securely to the base and recheck the alignment.
- g) Drill, ream, and dowel the driver feet and pump feet to the base.
- h) Re-check alignment and connect the coupling halves. Install the coupling guard (if supplied).

**4.5.4 Alignment criteria**

The following maximum Total Indicator Reading (TIR) is recommended:

Parallel Misalignment: 0.050 mm (0.002 in.)

Total Angular Misalignment: 0.025 mm (0.001 in.) per 25 mm (1.0 in.) of coupling hub radius.

When checking parallel alignment, the TIR shown is twice the value of the actual shaft displacement. Align in the vertical plane first, then horizontally by moving motor. When performing final alignment, check for soft-foot under the driver. An indicator placed on the coupling should not indicate more than 0.05 mm (0.002 in.) in the vertical direction, when any driver foot fastener is loosened.

While the pump is capable of operating with the maximum misalignment shown above, maximum pump reliability is obtained by near perfect alignment of 0.05 to 0.10 mm (0.002 to 0.004 in.) TIR parallel and 0.05 mm (0.002 in.) per 100 mm (4 in.) of coupling flange diameter as TIR angular misalignment. This covers the full series of couplings available.

**Note:**

Pumps with thick flanged non-spacer couplings can be aligned by using a straight-edge across the outside diameters of the coupling hubs and measuring the gap between the machined faces using feeler gauges, measuring wedge or calipers. When the electric motor has sleeve bearings it is necessary to ensure that the motor is aligned to run on its magnetic centerline.



Refer to the motor User Instructions for details. A button (screwed into one of the shaft ends) is normally fitted between the motor and pump shaft ends to fix the axial position.



**CAUTION** If the motor does not run in its magnetic centre the resultant additional axial force may overload the pump thrust bearing.



Complete piping and see sections 4.8, *Final shaft alignment check* up to and including section 5.0, *Commissioning, startup, operation and shutdown* before connecting driver and checking actual rotation. Tighten the motor base bolts and recheck the offset, and coupling level.

**Note:**

Due to the many variations and complexity of installations, it is recommended that a Flowserve Pump Division Service Representative be hired to assist in installation and alignment on long shafted vertical units.

**4.6 Piping**



**CAUTION** Protective covers are fitted to the pipe connections to prevent foreign bodies entering during transportation and installation. Ensure that these covers are removed from the pump before connecting any pipes.

#### 4.6.1 Pipework velocities

In order to minimize friction losses and hydraulic noise in the pipe work, it is a good practice to choose pipe work that is one or two sizes larger than the pump suction and discharge. Typically main pipe work velocities should not exceed 2 m/s (6 ft/sec) suction and 3 m/s (9 ft/sec) on the discharge. Take into account the available NPSH that must be higher than the required NPSH of the pump.



Never use the pump as a support for piping.

##### 4.6.1.1 Piping strains

Pipe strains are a common cause of misalignment, hot bearings, worn couplings, and vibration. Satisfactory operation cannot be maintained when the piping imposes a force on the pump. Misaligned piping flanges can spring and pull a pump out of position when their bolts are drawn up. Flanges must have flat faces and be brought squarely together before the bolts are tightened.

To avoid breaking the flanges when tightening the bolting, mating pipe flanges should also have flat faces and full face gaskets should be used. Suction and discharge pipes, and associated equipment, should be supported and anchored near, but independent of the pump so that no strain will be transmitted to the pump casing.

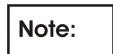

Pipe couplings that are not axially rigid are sometimes used in the discharge and/or suction piping to avoid transmitting any piping strains caused by system pressure, thermal expansion or pipe misalignment. Such pipe couplings allow transmittal to the pump, a force equal to the area of the expansion joint times the pressure in the piping. These forces can have a significant magnitude and it is impractical to design the pump casing, base plate, support, etc., to withstand them.

Consequently, when pipe couplings lack axial rigidity, a suitable pipe anchor must be installed between it and the pump proper. Alternately, adequate restraining devices should be used and properly adjusted to prevent these forces from being transmitted to the pump. Maximum forces and moments allowed on the pump flanges vary with the pump size and type.

To minimize these forces and moments that may, if excessive, cause misalignment, hot bearings, worn couplings, vibration and the possible failure of the pump casing, the following points should be strictly followed:

- Prevent excessive external pipe load
- Never draw piping into place by applying force to pump flange connections
- Do not mount expansion joints so that their force, due to internal pressure, acts on the pump flange



Ensure piping and fittings are flushed before use.



Ensure piping for hazardous liquids is arranged to allow pump flushing before removal of the pump.

#### 4.6.2 Suction piping

Experience has shown that the major source of trouble in centrifugal pump installations, other than misalignment, is traceable to a faulty suction line. The utmost attention must be given to this portion of the installation to ensure that the pump receives hydraulically stable flow. The suction piping should be direct as possible and its length held to a minimum. If a long suction line is required, increase the pipe size to reduce friction losses. Then gradually reduce the pipe size in steps before entering the pump. The piping should be run without having high spots and should have a continual rise toward the pump. This prevents air pockets.

Clean out all debris from the suction line and wet well prior to operating the pumps. Care should be exercised to keep the suction piping air tight and sealed against leakage.

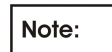

Isolation valve in suction line is strongly recommended to facilitate future servicing needs. An isolation valve is recommended in the suction line, if a positive head exists.

#### 4.6.2.1 Suction piping guidelines

- a) The inlet pipe should be one or two sizes larger than the pump inlet bore and pipe bends should be as large a radius as possible.
- b) Pipe work reducers should have a maximum total angle of divergence of 15 degrees.
- c) On suction lift the piping should be inclined up towards the pump inlet with eccentric reducers incorporated to prevent air locks.
- d) On positive suction, the inlet piping must have a constant fall towards the pump.
- e) Flow should enter the pump suction with uniform flow, to minimize noise and wear. This is particularly important on large or high-speed pumps that should have a minimum of four diameters of straight pipe on the pump suction between the elbow and inlet flange.
- f) Inlet strainers, when used, should have a net free area of at least three times the inlet pipe area.
- g) Do not install elbows at an angle other than perpendicular to the shaft axis. Elbows parallel to the shaft axis will cause uneven flow.
- h) Except in unusual circumstances strainers are not recommended in inlet piping. If considerable foreign matter is expected a screen installed at the entrance to the wet well is preferable.
- i) Fitting an isolation valve will allow easier maintenance.
- j) Never throttle pump on suction side and never place a valve directly on the pump inlet nozzle.

#### 4.6.3 Discharge piping

A check valve and a gate valve are normally installed in the discharge line. The check valve is normally placed between the pump and the gate valve to protect the pump from any excessive back pressure and reverse rotation that may be caused by water running back through the pump casing during a driver or power failure. Any reverse flow through the pump or excessive back pressure should be kept to an absolute minimum. The check valve will also prevent suspended solids from accumulating in the casing and will increase wearing life.

- Pipe work reducers should have a maximum total angle of divergence of 9 degrees.
- Fitting an isolation valve will allow easier maintenance.
- A compound pressure gauge should be connected to the suction and a pressure gauge connected to the discharge side of each pump. Mount the gauges at a convenient location as they are necessary for any adequate check on pump performance.

#### 4.6.4 Auxiliary piping

##### 4.6.4.1 Drains

Pipe pump casing drains and gland leakage to a convenient disposal point.

##### 4.6.4.2 Pumps fitted with gland packing

When suction pressure is below ambient pressure it is necessary to feed the gland packing with liquid to provide lubrication and prevent the ingress of air. This is normally achieved with a supply from the pump discharge volute to the stuffing box.

If the pumped liquid is dirty and cannot be used for sealing, a separate clean compatible liquid supply to the gland at 1 bar (15 psi) above suction pressure is recommended.

##### 4.6.4.3 Pumps fitted with mechanical seals

Single seals requiring re-circulation will normally be provided with the auxiliary piping from pump casing already fitted.

Special seals may require different auxiliary piping to that described above. Consult seal User Instructions and/or Flowserve, if unsure of correct method or arrangement

For pumping hot liquids, to avoid seal damage, it is recommended that any external flush/cooling supply be continued after stopping the pump

#### 4.6.5 Final checks

Check the tightness of all bolts in the suction and discharge pipe work. Check also the tightness of all foundation bolts.

#### 4.7 Electrical connections



**DANGER**

Electrical connections must be made by a qualified Electrician in accordance with relevant local national and international regulations.



It is important to be aware of the EUROPEAN DIRECTIVE on potentially explosive areas where compliance with IEC60079-4 is an additional requirement for making electrical connections.



It is important to be aware of the EUROPEAN DIRECTIVE on electromagnetic compatibility when wiring up and installing equipment on site. Attention must be paid to ensure that the techniques used during wiring/installation do not increase electromagnetic emissions or decrease the electromagnetic immunity of the equipment, wiring or any connected devices. If in any doubt contact Flowserve for advice.



**DANGER** The motor must be wired up in accordance with the motor manufacturer's instructions (normally supplied within the terminal box) including any temperature, earth leakage, current, and other protective devices as appropriate. The identification nameplate should be checked to ensure the power supply is appropriate.



A device to provide emergency stopping must be fitted. If not supplied pre-wired to the pump unit, the controller/starter electrical details will also be supplied within the controller/starter. For electrical details on pump sets with controllers see the separate wiring diagram.



**CAUTION** See section 5.3, *Direction of rotation* before connecting the motor to the electrical supply.

#### 4.8 Final shaft alignment check

After connecting piping to the pump, rotate the shaft several times by hand to ensure there is no binding and all parts are free.



**CAUTION** Recheck the coupling alignment, as previously described, to ensure no pipe strain. If pipe strain exists, correct piping.

#### 4.9 Protection systems



The following protection systems are recommended particularly if the pump is installed in a potentially explosive area or is handling a hazardous liquid. If in doubt consult Flowserve.

If there is any possibility of the system allowing the pump to run against a closed valve or below minimum continuous safe flow a protection device should be installed to ensure the temperature of the liquid does not rise to an unsafe level.

If there are any circumstances in which the system can allow the pump to run dry, or start up empty, a power monitor should be fitted to stop the pump or prevent it from being started.

This is particularly relevant if the pump is handling a flammable liquid. If leakage of product from the pump or its associated sealing system can cause a hazard it is recommended that an appropriate leakage detection system is installed.

To prevent excessive surface temperatures at bearings it is recommended that temperature or vibration monitoring are carried out on a regular basis.

## 5 COMMISSIONING, START-UP, OPERATION AND SHUTDOWN



**CAUTION** These operations must be carried out by fully qualified personnel.

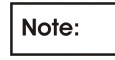

To ensure safety, keep the power supply turned off to the motor and pump accessories during commissioning.

### 5.1 Pre-commissioning procedure

The gland is to be filled with grease and flush supply to be in place. Flush piping to be checked for leaks. Mechanical seals to be checked for leaks, flush flow and pressure. In addition, follow the list below.

- a) Pump bearings must be filled with the recommended lubricant to avoid running dry and to guarantee acceptable performance of the pump.
- b) Check all vent connections for complete filling of the pump.
- c) Check the direction of rotation of the pump (Coupling spacer dismantled).
- d) The pump rotor and the shaft seal must be in correct axial position.
- e) Check the readiness of all auxiliary systems (seal sys. lubrication sys.,) for start up.
- f) All pipe work, including the internal and the auxiliary pipe work, must be connected correctly and must be absolutely tight. Check the tightness of all connections of the auxiliary pipe work. The suction valve must be open, the discharge valve shall be closed or partially open as required.
- g) Turn the pump by hand, if required with the help of a lever, to check the free rotation of the rotor. The rotor must turn uniformly and noiselessly. Some resistance may be felt due to the friction in the bearings and seals.
- h) Check the readiness of the driver for start up.

Refer to driver User instructions before energizing the motor.

### 5.2 Pump Lubrication

Determine the mode of lubrication of the pump set, e.g. grease, oil, and product lubrication.



**CAUTION** Recommended grease types with their brand names and quantities are provided in section 5.2.5. Grease lubricated pumps and electric motors are supplied pre-greased.

**5.2.1 Bearings – oil lubricated**

MNF/MNC pumps are furnished with grease lubricated bearings as standard. At the customer's request, special arrangements can be made to lubricate the bearings with oil. However, although the oil and grease lubricated bearing frames are physically interchangeable in whole, individual parts may or may not be interchangeable. Check with the nearest Flowserve Sales Representative to determine inter-changeability of parts.



Before starting the pump, check the lubricant level or the required quantity.

**5.2.2 Bearings – grease lubricated**

MNF & MNC pumps are furnished with grease lubricated bearings with grease fittings on the line and thrust bearing ends of the bearing housing; see sec 5.2.3.1.

Before starting the pump, check the bearing frame cavities for grease and add grease as necessary. The suggested frequency and grease quantity for re-lubrication are provided in sec. 5.2.5.2. After start up, remove the grease fittings or pipe plug closest to the cover and allow the excess grease to flow out.

**5.2.3 Filling the grease reservoir**



The grease flowing out of the bearing frame may be hot and under pressure. Bearings may run slightly hot immediately after adding new grease.

**5.2.3.1 Grease fittings**

Use grease fittings provided to fill the grease

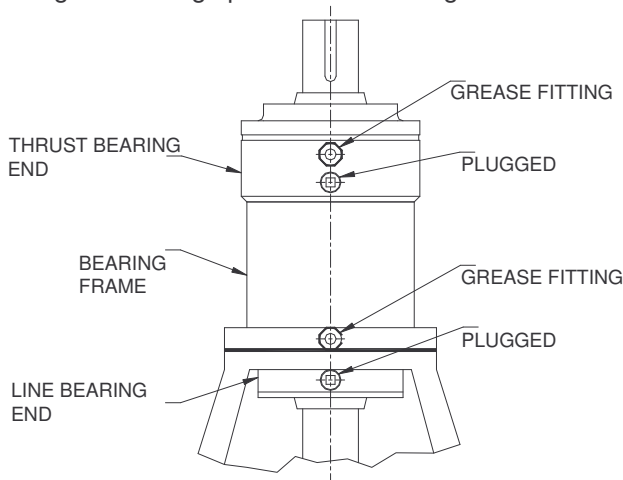

**5.2.4 Bearing operating temperatures**

The maximum operating temperatures for anti-friction bearings will differ from unit to unit. In general, bearing frames using Timken bearings can run 40°C (100°F) higher above ambient. This should be no cause for alarm. However, continuously rising temperatures, or an abrupt temperature rise, is indicative of possible trouble. These symptoms require immediate stopping of the pump and a thorough investigation to determine the cause of the Trouble.

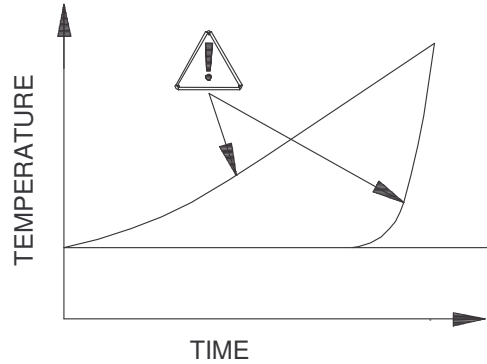

**5.2.5 Selection of grease lubricants**

The bearings are to be lubricated with a premium quality lithium based NGLI # 2 grease suitable for anti-friction bearing use. The grease should have a viscosity range of 150 to 220 cSt (mm<sup>2</sup>/sec) at 40 °C (100 °F) and Timken load rating of 16 kg (35 lb.) minimum. The grease should contain rust and oxidation inhibitors and extreme pressure additives

Others greases meeting the above requirements may also be used.

**5.2.5.1 Recommended grease lubricants**

<b>AMOCO</b>	AMOLITH EP2
<b>CHEVRON</b>	DURALITH EP2
<b>EXXON</b>	LIDOK EP2
<b>MOBIL</b>	MOBILUX EP2
<b>BP</b>	ENERGREASE-LS-EP2
<b>SHELL</b>	ALVANIA EP2
<b>TEXACO</b>	MULTIFAK EP2

### 5.2.5.2 Recommended grease fill quantities

Frame No.	Line Bearing, Timken CUP P.N./ CONE P.N.	Thrust Bearing, Timken CUP P.N./ CONE P.N.	Initial Fill g (oz)				Suggested Re-Lubrication g (oz)		
			Line Bearing		Thrust Bearing		Freq.	Qty. Ounces	
			Conn. <sup>1</sup>	Cover <sup>2</sup>	Conn. <sup>1</sup>	Cover <sup>2</sup>	Hours	Line Brg	Thr. Brg
4T	JLM506849/ JLM506810	M804048/ M804010	43 (1.5)	9 (0.3)	28 (1.0)	23 (0.8)	300	9 (0.3)	9 (0.3)
5T	29685/ 29620	72225C/ 72487	56 (2.0)	14 (0.5)	56 (2.0)	56 (2.0)	300	11 (0.4)	11 (0.4)
6	6536/ 6580	6536/ 6580	369 (13.0)	114 (0.4)	369 (13.0)	225 (8.0)	300	28 (1.0)	28 (1.0)
6A	HM218210/ HM218248	9220/ 9285 <sup>3</sup>	56 (2.0)	42 (1.5)	85 (3.0)	127 (4.6)	300	14 (0.5)	14 (0.5)
7L	JM822010/ JM822049	9321/ 9386H	595 (21.0)	85 (3.0)	370 (13.0)	255 (9.0)	300	28 (1.0)	28 (1.0)
7H	JHM522610/ JHM522649	98788/ 98400	480 (17.0)	225 (8.0)	565 (20.0)	650 (23.0)	300	28 (1.0)	42 (1.5)
8L	74850/ 74500	HM926710/ HM926740	990 (35.0)	200 (7.0)	680 (24.0)	310 (11.0)	500	42 (1.5)	42 (1.5)
8H	95925/ 95500	HH926710/ HH926749	880 (31.0)	425 (15.0)	1135 (40.0)	1135 (40.0)	500	56 (2.0)	56 (2.0)
8HA	82931/ 82576	HH926710/ HH926749	880 (31.0)	625 (22.0)	1135 (40.0)	1135 (40.0)	500	56 (2.0)	56 (2.0)
9H	H239610/ H239640	H936310/ H936349	1560 (55.0)	625 (22.0)	1845 (65.0)	1700 (60.0)	500	70 (2.5)	70 (2.5)
9HA	93125/ 93825	H936310/ H936349	1560 (55.0)	480 (17.0)	1845 (65.0)	1700 (60.0)	500	70 (2.5)	70 (2.5)

- This value indicates the amount of grease to be added to the bearing through the grease connection. For horizontal units, the space between the bearing and the grease retainer will be 2/3 full.
- This value indicates the amount of grease required for packing the space between each bearing and its respective cover. The space between bearings and their respective covers should be 1/3 full.
- This bearing must comply to Timken Co. inspection code 20481

### 5.2.6 Grease change schedule

When grease nipples are fitted, one charge between grease changes is advisable for most operating conditions.

The characteristics of the installation and severity of service will determine the frequency of lubrication. Lubricant and bearing temperature analysis can be useful in optimizing lubricant change intervals.

The bearing temperature may be allowed to rise to 40 °C (100 °F) above ambient. If the temperature is exceeding this limit, a special consideration may have to be given to set the alarm and trip. Consult Flowserve with the temperature data for recommendations (If needed).

Never mix greases containing different bases, thickeners or additives.

### 5.3 Impeller clearance

(See section 6.1.6)

### 5.4 Direction of rotation

Ensure the pump is given the same rotation as the pump direction arrow cast on the pump casing.

To avoid dry running the pump must either be filled with liquid or have the flexible coupling disconnected before driver is switched on.

If maintenance work has been carried out to the site's electricity supply, the direction of rotation should be re-checked as above in case the supply phasing has been altered.

## 5.5 Guarding



Guarding is supplied fitted to the pump set. If this has been removed or disturbed ensure that all the protective guards around the pump coupling and exposed parts of the shaft are securely fixed.

## 5.6 Priming and auxiliary supplies



Ensure all electrical, hydraulic, pneumatic, sealant and lubrication systems (as applicable) are connected and operational.



Ensure the inlet pipe and pump casing are completely full of liquid before starting continuous duty operation.

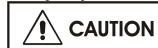

Prime your pump before starting. Do not run the pump dry!



Observe extreme caution when priming, venting and draining hazardous liquids. Wear protective clothing in the presence of hazardous, caustic, volatile, inflammable or hot liquids. Do not breathe the toxic vapors. Do not allow sparking, flames or hot surfaces in the vicinity of the equipment.

Priming a centrifugal pump means removing the air, gas or vapor from the pump casing and suction piping. Internal pump parts depend on liquid for lubrication and may seize if the casing is not completely filled with liquid prior to starting. Priming a pump can be accomplished by any of the following methods, depending on the installation.

### 5.6.1 Positive suction head (pressure)

With a positive suction head on the pump, priming is accomplished in the following manner:

- a) Open all suction valves to allow liquid to enter the suction piping and pump casing.
- b) Open the vent valve located on the highest point on the casing (or discharge piping) to release all entrapped air.
- c) When liquid appears as a steady stream (no air bubbles) the pump is primed and may be started.

### 5.6.2 Negative suction head (vacuum)

#### **Priming by Ejector or Exhauster**

When steam, high pressure water or compressed air is available, the pump may be primed by attaching an ejector to the highest point for venting the pump casing.

#### **Proceed as follows:**

- a) Open the suction valve.
- b) Start the ejector to exhaust the air from the pump and suction line.
- c) When the ejector waste pipe exhausts liquid continuously, the pump is primed and may be started.

To ensure that the prime is not lost, allow the ejector to operate until the pump is started and is up to operating speed. A continuous stream of liquid will indicate that the prime is being held.

### 5.6.3 Priming by vacuum pump

Priming may be accomplished by the use of a wet type vacuum pump. The procedure is the same as priming by ejector.

## 5.7 Starting the pump

### 5.7.1 Preliminary to starting

Read this instruction book thoroughly before starting the unit. Make sure the following items are checked before starting:

- a) Pack the stuffing box and leave the gland nuts loose.
- b) Verify alignment has been accomplished as indicated in section 4.5.
- c) Lubricate the driver, as required, per the drive manufacturer's instructions.
- d) Check the direction of rotation of the driver. The arrow on the pump casing will show the correct rotation.
- e) Lubricate the couplings, as required per the coupling manufacturer's instructions.
- f) Check pump bearing lubrication as indicated in section 5.
- g) The pump must be filled with liquid (primed). If a priming device is used, it must be operated before the pump is started.
- h) Packing:
  - For packed boxes, the gland nuts must be loose.
  - Fill the packing grease reservoir if using a grease packed box, or If the unit is equipped with an independent flush to the stuffing box, turn on the flush liquid and verify that the proper pressure and flow are being supplied.
- i) If the wearing rings are provided with a flushing provision, turn on the flush liquid.



### 5.7.2 Pump start up

The procedure for starting the unit will vary somewhat with each installation, however the following steps generally apply:



Turn off power to the driver.

- a) Turn the pump over by hand to verify that the pump rotor turns freely. If it is bound, do not operate the pump until the cause of the trouble is located.
- b) Make sure the suction valve is open
- c) **CAUTION** Ensure flushing and/or cooling/heating liquid supplies are turned ON before starting the pump
- d) CLOSE the outlet valve
- e) Prime the pump.
- f) Ensure all vent connections are closed before starting.
- g) Start the driver per the manufacturer's instruction.
- h) Open the discharge valve slowly as pressure is built up on the discharge side of the pump. If the valve does not open within three minutes, shutdown the unit and determine the cause.
- i) **CAUTION** If NO pressure, or LOW pressure, STOP the pump. Refer to section 7, *Faults; causes and remedies*, for fault diagnosis.
- j) Adjust the gland nuts on the packing.
- k) When in service, bearing temperature, suction, discharge, and stuffing box pressure, stuffing box operation, noise, and vibration for several hours.

### 5.7.3 Normal vibration levels, alarm and trip

For guidance and general data, the subject pump types with rigid supports are classified based on power ratings as provided by Hydraulic Institute standards.



**CAUTION** Alarm and trip values for installed pumps should be based on the actual measurements (N) taken on the pump in a fully commissioned (new) condition. Measuring vibration at regular intervals and recording will help to track any deterioration in pump or operating conditions.

Motor rating kW (hp)	Vibration velocity-unfiltered	mm/sec (in./sec) rms
0.75-to 7.5 (1-10)	<b>N</b>	6.6 (0.22)
7.5 to 75 (10-100)	<b>N</b>	6.6 (0.22)-8.0(0.32)
100-298 (100-400)	<b>N</b>	8.0 (0.32)-8.6(0.34)
298-750 (400-1000)	<b>N</b>	8.6 (0.34)-

Alarm =N X1.25; Trip= N X2.0

### 5.7.4 Motor start/stop frequency

Even though motors are normally suitable for at least two consecutive starts, it is recommended to restart only after coasting to rest between starts (minimum of 15 minutes gap is recommended) with the motor initially at ambient temperature. If more frequent starting is necessary, refer to driver manufacturer's User Instructions.



**CAUTION** The number of motor start and stops in any given time affects motor life.



If the motor is expected to experience multi starts in any given time, please refer to the driver's user instructions before the pump is put into operation.

## 5.8 Running or operation

### 5.8.1 Venting the pump



Vent the pump to enable all trapped air to escape taking due care with hot or hazardous liquids.

Under normal operating conditions, after the pump has been fully primed and vented, it should be unnecessary to re-vent the pump.

### 5.8.2 Pumps fitted with packed gland

If the pump has a packed gland there must be some leakage from the gland. Gland nuts should initially be finger-tight only. Leakage should take place soon after the stuffing box is pressurized.



The gland must be adjusted evenly to give visible leakage and concentric alignment of the gland ring to avoid excess temperature.

If no leakage takes place the packing will begin to overheat. If overheating takes place the pump should be stopped and allowed to cool before being re-started. When the pump is re-started, check to ensure leakage is taking place at the packed gland. If hot liquids are being pumped it may be necessary to slacken the gland nuts to achieve leakage.

The pump should be run for 30 minutes with a steady leakage and the gland nuts tightened by 10 degrees at a time until leakage is reduced to an acceptable level. As a thumb rule a minimum of 30 drops /second for every inch of sleeve diameter will keep the gland in safe operating condition. Seating of the packing may take another 30 minutes.

 Care must be taken when adjusting the gland on an operating pump. Safety gloves are essential. Loose clothing must not be worn to avoid being caught up by the pump shaft. Shaft guards must be replaced after the gland adjustment is complete.

 **CAUTION** Never run gland packing dry, even for a short time.

### 5.8.3 Pumps fitted with mechanical seal

Mechanical seals require no adjustment. Any slight initial leakage will stop when the seal is run in.

Before pumping dirty liquids it is advisable, if possible, to run in the pump mechanical seal using clean liquid to safeguard the seal face.

 **CAUTION** External flush or quench should be started before the pump is run and allowed to flow for a period after the pump has stopped.

 **CAUTION** Never run a mechanical seal dry, even for a short time.

### 5.8.4 Bearings

 If the pumps are working in a potentially explosive atmosphere, temperature or vibration monitoring at the bearings is recommended.

If bearing temperatures are to be monitored it is essential that a benchmark temperature is recorded at the commissioning stage and after the bearing temperature has stabilized.

- Record the bearing temperature (t) and the ambient temperature (ta)
- Estimate the likely maximum ambient temperature (tb)
- Set the alarm at  $(t+tb-t_a+5) \text{ } ^\circ\text{C}$  [ $(t+tb-t_a+10) \text{ } ^\circ\text{F}$ ] and the trip at  $100 \text{ } ^\circ\text{C}$  ( $212 \text{ } ^\circ\text{F}$ ) for oil lubrication and  $105 \text{ } ^\circ\text{C}$  ( $220 \text{ } ^\circ\text{F}$ ) for grease lubrication

The maximum operating temperatures for anti-friction bearings will differ from pump to pump. In general, bearing frames using Timken bearings can run  $40 \text{ } ^\circ\text{C}$  ( $100 \text{ } ^\circ\text{F}$ ) or higher above ambient. This should be no cause for alarm. However, continuously rising temperatures, or an abrupt temperature rise, are indicative of possible trouble. These symptoms

require immediate stopping of the pump and a thorough investigation to determine the cause of the trouble.

The pump bearings will show a definite temperature rise immediately after lubrication and should be operated for 5 to 10 hours to allow the temperature to stabilize.

It is important, particularly with grease lubrication, to keep a check on bearing temperatures. After start up the temperature rise should be gradual, reaching a maximum after approximately 1.5 to 2 hours. This temperature rise should then remain constant or marginally reduce with time.

### 5.8.5 Reduced Capacity operation.

Generally, Flowserve non-clog pumps are designed for continuous operation above 65% of the peak efficiency capacity at maximum RPM and impeller diameter. They are suitable for occasional or intermittent operation at capacities outside these limits, however, pump operation may be noisy and component life may be reduced.

These limitations are placed because the impellers have wide discharges and at other capacities high magnitudes of radial reactions are encountered and flow re-circulation may occur. This is an inherent design characteristic for a pump of this type.

In many cases, particularly in sewage pumping applications, reduced capacities are met by a reduction in pump speed and no throttling is used.



Under these circumstances, these part capacity applications are not nearly so critical because of lower pump speed and relatively lower pump operating heads.

Refer applications where pump operation at other capacities are anticipated to your nearest Flowserve Sales Representative.

### 5.8.6 Suction lift

Sometimes the suction conditions imposed upon a centrifugal pump are extremely unfavorable and lead to a complete breakdown of the pump operation. The suction lift must be kept within the suction limitations for which the pump was sold. If the original operating conditions must be changed for any reason, consult your nearest Flowserve Sales Representative. Care should also be exercised to keep the suction piping air tight and sealed against leakage.

## 5.9 Stopping and shutdown

- a)  Close the outlet valve slowly.
- b) Shut down the driver according to driver manufacturer's instruction.
- c) For pumps operating under positive suction head, after stopping the pump, continue injecting water into the stuffing box to avoid the entrance of contaminants in to the stuffing box sealing area, if required.
- d)  Do not tighten the gland to stop liquid leaking out or air leaking into the stuffing box
- e) If wearing rings are provided with a flushing provision, turn off liquid to the rings several minutes after the pump is stopped.

## 5.10 Hydraulic, mechanical and electrical duty

This product has been supplied to meet the performance specifications of your purchase order, however it is understood that during the life of the product these may change. The following notes may help the user decide how to evaluate the implications of any change. If in doubt contact your nearest Flowserve office.

### 5.10.1 Specific gravity (SG)

Pump capacity and total head in meters (feet) do not change with SG, however pressure displayed on a pressure gauge is directly proportional to SG. Power absorbed is also directly proportional to SG. It is therefore important to check that any change in SG will not overload the pump driver or over-pressurize the pump.

### 5.10.2 Viscosity

For a given flow rate the total head reduces with increased viscosity and increases with reduced viscosity. Also for a given flow rate the power absorbed increases with increased viscosity, and reduces with reduced viscosity. It is important that checks are made with your nearest Flowserve office if changes in viscosity are planned.

### 5.10.3 Pump speed

Changing pump speed effects flow, total head, power absorbed,  $NPSH_R$ , noise and vibration. Flow varies in direct proportion to pump speed, head varies as speed ratio squared and power varies as speed ratio cubed. The new duty, however, will also be dependent on the system curve. If increasing the speed, it is important therefore to ensure the maximum pump working pressure is not exceeded, the driver is not overloaded,  $NPSH_A > NPSH_R$ , and

that noise and vibration are within local requirements and regulations.

### 5.10.4 Net positive suction head ( $NPSH_A$ )

$NPSH_A$  available ( $NPSH_A$ ) is a measure of the head available in the pumped liquid, above its vapor pressure, at the pump suction branch.

$NPSH_R$  required ( $NPSH_R$ ) is a measure of the head required in the pumped liquid, above its vapor pressure, to prevent the pump from cavitating. It is important that  $NPSH_A > NPSH_R$ . The margin between  $NPSH_A > NPSH_R$  should be as large as possible.

If any change in  $NPSH_A$  is proposed, ensure these margins are not significantly eroded. Refer to the pump performance curve to determine exact requirements particularly if flow has changed. If in doubt please consult your nearest Flowserve office for advice and details of the minimum allowable margin for your application.

### 5.10.5 Pumped flow

Flow must not fall outside the minimum and maximum continuous safe flow shown on the pump performance curve and or data sheet.

## 6 MAINTENANCE



It is the plant operator's responsibility to ensure that all maintenance, inspection and assembly work is carried out by authorized and qualified personnel who have adequately familiarized themselves with the subject matter by studying this manual in detail.

Any work on the machine must be performed when it is at a standstill. It is imperative that the procedure for shutting down the machine is followed, as described in section 5.9.

On completion of work all guards and safety devices must be re-installed and made operative again.

Before restarting the machine, the relevant instructions listed in section 5, *Commissioning, start up, operation and shut down* must be observed.



Oil and grease leaks may make the ground slippery. Machine maintenance must always begin and finish by cleaning the ground and the exterior of the machine.

If platforms, stairs and guard rails are required for maintenance, they must be placed for easy access to areas where maintenance and inspection are to be carried out. The positioning of these accessories must not limit access or hinder the lifting of the part to be serviced.

When air or compressed inert gas is used in the maintenance process, the operator and anyone in the vicinity must be careful and have the appropriate protection.

- Do not spray air or compressed inert gas on skin
- Do not direct an air or gas jet towards other people
- Never use air or compressed inert gas to clean clothes

Before working on the pump, take measures to prevent an uncontrolled start. Put a warning board on the starting device with the words: **"Machine under repair: do not start"**.

With electric drive equipment, lock the main switch open and withdraw any fuses. Put a warning board on the fuse box or main switch with the words: **"Machine under repair: do not connect"**.

Never clean equipment with inflammable solvents or carbon tetrachloride. Protect yourself against toxic fumes when using cleaning agents.

## 6.1 Maintenance schedule



It is recommended that a maintenance plan and schedule is adopted, in line with these User Instructions. It should include the following:

- a) Any auxiliary systems installed must be monitored, if necessary, to ensure they function correctly.
- b) Gland packings must be adjusted correctly to give visible leakage and concentric alignment of the gland follower to prevent excessive temperature of the packing or follower.
- c) Check for any leaks from gaskets and seals. The correct functioning of the shaft seal must be checked regularly.
- d) Check bearing lubricant level, and if the hours run show a lubricant change is required.
- e) Check that the duty condition is in the safe operating range for the pump.
- f) Check vibration, noise level and surface temperature at the bearings to confirm satisfactory operation.
- g) Check dirt and dust is removed from areas around close clearances, bearing housings and motors.

- h) Check coupling alignment and re-align if necessary.

Our specialist service personnel can help with preventative maintenance records and provide condition monitoring for temperature and vibration to identify the onset of potential problems.

If any problems are found the following sequence of actions should take place:

- a) Refer to section 7, *Faults; causes and remedies*, for fault diagnosis.
- b) Ensure equipment complies with the recommendations in this manual.
- c) Contact Flowserve if problem persists.

### 6.1.1 Routine inspection (daily/weekly)

Hourly and daily observations should be made of the pump operation to avert trouble. Whether or not you consider a log of these inspections necessary, the operator must be alert for irregularities in the operation of the pumps. He should immediately report any trouble symptoms that are detected. Stuffing box operation and bearing temperatures should be checked periodically. An abrupt change in bearing temperatures is much more indicative of trouble than a consistently high temperature. A change in the sound of a running pump is also a warning of possible trouble.



The following checks should be made and the appropriate action taken to remedy any deviations:

- a) Check operating behavior. Ensure noise, vibration and bearing temperatures are normal.
- b) Check that there are no abnormal fluid or lubricant leaks (static and dynamic seals) and that any sealant systems (if fitted) are full and operating normally.
- c) Check that shaft seal leaks are within acceptable limits.
- d) Check the level and condition of oil lubricant. On grease lubricated pumps, check running hours since last recharge of grease or complete grease change.
- e) Check any auxiliary supplies e.g. heating/cooling, if fitted, are functioning correctly.



Refer to the manuals of any associated equipment for routine checks needed.

**6.1.2 Periodic inspection (six monthly)**

Check the stuffing box for free movement of the gland. Clean and oil the gland studs and nuts. Closely observe the stuffing box for excessive leakage which cannot be reduced by gland adjustment, and replace the packing as necessary. Check the pump running records for hourly usage to determine if the bearings should be inspected and re-lubricated. The maximum recommended time between cleaning and lubrication change is one year, regardless of usage. The severity of the environment and conditions of service may dictate shorter frequency.

- a)  Check foundation bolts for security of attachment and corrosion.
- b) Check pump running records for hourly usage to determine if bearing lubricant requires changing.
- c) The coupling should be checked for correct alignment and worn driving elements.



Refer to the manuals of any associated equipment for periodic checks needed.

**6.1.3 Complete overhauls**

Frequency of a complete overhaul depends upon the hours of pump operation, the severity of the conditions of service, the materials used in the pump construction, and the care the pump receives in operation.

Do not open your pump for inspection unless there is definite evidence that the capacity has fallen off excessively or unless there is indication of trouble inside the pump or in the bearings.

**6.1.4 Complete cleaning during a major overhaul**

If the bearings need cleaning, or if an overhaul period offers the opportunity, the lubricant cavities and bearings should be cleaned.

After the pump has been dismantled, use a brush and wash out the housing with hot oil, 94° to 115°C (200° to 240°F), or non-toxic solvent. Flush the housing with a light mineral oil to prevent rust and to remove all traces of solvent.

Using a brush dipped in hot oil, 82° to 94°C (180° to 200°F), remove any solid particles while gently spinning the bearing. If badly oxidized grease is present and refuses to come off with the above procedure, the bearings should be immersed in a hot non-toxic solvent and allowed to soak. Brush and spin the bearings until the oxidized grease is removed.

Difficult spots can sometimes be removed with a mixture of alcohol and light mineral solvent. Flush the bearings with clean, light oil to remove any contaminated oil

**6.1.5 Maintenance of casings**

The casing waterways must be kept clean and clear. Whenever a unit has been dismantled, clean the waterways of the casing. These pumps have two casing gaskets that may be damaged when the pump is opened. One gasket is between the stuffing box head and the casing, and the other is between the suction head and the casing.

New casing gaskets must be the same thickness and material as the original so that they will compress to the same extent. Gaskets originally installed were Aramid fiber with SBR rubber. When installing a new gasket proceed as follows:

- a) Clean the flanges. Dirt and scale provide leakage paths.
- b) Lubricate the fastener threads and mounting face. Threads should be well formed and free running.
- c) Trim the gasket edges squarely and neatly and coat the gasket with a suitable release agent.
- d) Place the gasket on the flat surface of the flange and assemble the flange joints and run up all the fasteners finger tight. Develop final torque using "Recommended Torques for Threaded Fasteners" at the end of this section, in about three equal steps by cross-tightening evenly.

**6.1.6 Maintenance of wearing rings**

Generally, the rings should be renewed or overhauled when the pump performance has decreased appreciably due to excessive wearing ring clearance. The original nominal design running clearance was 0.51 to 0.76 mm (0.020 to 0.030 in.) axially.

**Note:**

Pumps equipped with mechanical seals may require rotor removal and resetting of the seal after adjusting the wearing ring gap. Refer to mechanical seal manufacturer's instructions.

**6.1.6.1 Measuring wearing ring gap**

There are two methods for checking wearing ring clearance on pumps equipped with axial wearing ring construction. The simplest is to remove the suction head hand hole cover and check with a feeler gauge around the gap perimeter. The second method is follows:

**Note:** The bearing frame support bolts must be loosened to allow movement of the bearing frame during adjustment. Be sure to re-tighten the bolts when the wearing ring gap adjustment is completed.

- a) Disconnect pump coupling halves if required.
- b) Back off the bearing frame retaining screws between the bearing frame and the stuffing box approximately 1.5 mm (0.06 in.) Please do not remove the screws
- c) Tighten the two exterior jacking bolts to break the shim joint, then remove all shims.
- d) Back off the two jacking bolts until they are even with the bottom of the bearing frame flange. Tighten the bearing frame retaining screws until the impeller wearing ring seats against the casing wearing ring. Ensure that the gap between the bearing frame and stuffing box flange is even all the way around the perimeter.
- e) Measure the gap between the bearing frame flange and the stuffing box head flange. Add the desired amount of wearing ring gap to the measurement. This is the required amount of shims to be added between the bearing frame and the stuffing box head.

**6.1.6.2 Adjusting wearing ring gap**

After the actual ring gap has been determined, adjust the shim pack as required to obtain the desired ring gap. If the desired ring gap cannot be obtained because of having reached the limit of axial adjustment, one or both of the wearing surfaces will have to be restored or replaced.

- a) Tighten the two jacking bolts to allow until they are even with the bottom of the bearing flange.
- b) After the shims are in place, back off the two jacking bolts until they are even with the bottom of the bearing frame flange.
- c) Tighten the four bearing frame retaining screws. Ensure that the gap between the bearing frame and stuffing box flange is even all the way around the perimeter.
- d) Rotate the pump shaft by hand to check for free rotation. Recheck the gap and repeat steps a thru d as necessary.
- e) Recheck the coupling alignment and then replace the coupling bolts.

**Shim stock identification:**

Light Brown =	0.76 mm (.030 in.)
Yellow =	0.51 mm (.020 in.)
Brown =	0.25 mm (.010 in.)
Blue =	0.12 mm (.005 in.)

Each shim set consists of two halves, permitting easy removal. Each half must be the same thickness

**6.1.6.3 Removal of wearing rings**

The impeller and suction head wearing rings are held in place by screws locked in place using Loctite 271 or equivalent. They may require heating to 200 °C (400 °F) to allow removal.

**6.1.6.4 Mounting of wearing rings**

Clean the screw threads and taps. Clean the ring and the area where the ring is to be mounted. Mount the ring and secure it using screws with Loctite 271 or equivalent applied to the threads.

**Note:** New tapped holes may be required to facilitate installation of a new wearing ring. Use the wearing ring as a template.

**6.1.7 Maintenance of shaft and shaft sleeve**

When the pump is dismantled, examine the shaft carefully. Its condition should be checked at the impeller hub fit, under the shaft sleeve (if sleeve is removed), at the bearings, and under the coupling flange (if flange is removed). The shaft may become damaged by rusting or pitting due to leakage along the shaft at the impeller or shaft sleeve, excessive exposure to moisture, or mishandling.

Anti-friction bearings improperly fitted to the pump shaft may result in the bearing cone rotating on the shaft, thus causing undue damage. Check the shaft keyways for distortion. Excessive thermal stresses or corrosion may loosen the impeller on the shaft and damage the keyway. Replace a shaft that is bent or distorted. If wear on the shaft is slight, it may be possible to rebuild it by metal spraying or plating and re-grinding. This repair should be carried out by trained and competent personnel.

After a shaft has been repaired, check it for possible runout, maximum 0.051mm (0.002 in.) T.I.R. Recheck the runout after the bearing frame is completely assembled.

When the sleeve has become worn appreciably, it becomes difficult to adjust the packing to prevent leakage and it should be replaced. Excessively grooved and scored sleeves will tear new packing as soon as it is inserted into the stuffing box.

Any sleeve grooved more than 3.0 mm (0.12 in.) deep should immediately be replaced to avoid damage to other components.

**Note:** The shaft sleeve was mounted on the shaft using Loctite RC/680 and may require heating to approximately 230 °C (450 °F) for removal.

**6.1.7.1 Shaft sleeve removal**

Uniformly heat the shaft sleeve to 230 °C (450 °F) and remove the sleeve while the part is hot. If this does not work, uniformly heat the sleeve to 260 °C (500 °F) and douse with cold water. This will crack the sleeve and allow mechanical removal of the sleeve. If heating is not practicable, it will be necessary to cut the sleeve off.

**6.1.7.2 Mounting of shaft sleeve**

Clean the shaft and shaft sleeve thoroughly and remove any oil or grease from the mating surfaces with a non-toxic solvent. Allow the solvent to dry and apply Loctite type RC/680 or equivalent to the sleeve inside diameter and shaft O.D. Install the sleeve by continuously rotating it to ensure a full and even coating of the mating surfaces. Avoid holding the sleeve in one position until the sleeve keyway is in line with the shaft keyway. Immediately install the key. This prevents "freezing" of the shaft sleeve to the shaft. Apply adequate force to the shaft sleeve face to ensure proper seating of the sleeve against the shaft shoulder. This can be done by mounting the impeller on the shaft and tightening the impeller nut. Remove excess Loctite from the parting lines. Loctite sealant will be fully cured in six hours.

**6.1.8 Maintenance of packing**

Pumps equipped with mechanical seals may have altered stuffing box dimensions. Refer to the seal manufacturer's installation drawing for actual box dimensions.

Use a good grade of non-asbestos packing with a high temperature surface lubricant for packing the stuffing box. Do not under any circumstances use flax packing as rapid wear of the shaft sleeve may result. The procedure for repacking the stuffing box follows:

- a) Remove the split gland.
- b) Remove the old packing and seal cage halves and clean the stuffing box.

- c) Make sure the packing to be used is of the correct type and size. Measure the stuffing box to determine the proper length of packing; see section 6.1.8.1. Packing should be cut slightly shorter than measured to prevent butting of the ends and buckling.
- d) Insert each ring of packing separately, pushing it as far as possible into the stuffing box and seating it firmly. Stagger the rings so that successive joints are 90° to 180° apart.
- e) After installing two packing rings, insert the seal cage. It is important to make sure the seal cage is located directly under the seal water connection and that the installation of successive rings does not displace it.
- f) Continue adding more rings of packing. When the required number of packing rings have been added, install the gland and tighten the gland nuts by hand, then back off the nuts until the gland is loose. In tightening the gland, the nuts must be brought up uniformly so that the gland is not cocked and so that the packing is subjected to a uniform pressure.
- g) New packing has to be "run in". It is a good practice to start the pump with the stuffing box gland quite loose. After the pump has been running for approximately 10 to 15 minutes, gradually tighten the stuffing box gland nuts until leakage is reduced to a steady supply or trickle. Packing that is too tight in the box will cause undue friction and create heat that will glaze the packing and possibly score the shaft sleeve. Packing must remain soft and pliable.

**Note:** It may be impossible to add the last ring of packing to the stuffing box and still insert the gland. When this occasion arises, omit the last ring of packing and adjust the gland. Continue to tighten the gland as required, allowing for proper leakage, until the packing has seated itself well enough to allow the final ring to be inserted. Approximately 2 to 4 lpm (1/2 to 1 GPM) at 35 to 70 kPa (5 to 10 psi) above the maximum pump discharge pressure is recommended for sealing water. When grease sealing is used, a similar grease pressure should be maintained.

### 6.1.8.1 Stuffing Box Data

(All Dimensions in mm (Inches))

Bearing Frame	O.D. Sleeve (1)	I.D. Box (2)	Depth of Box	Packing Size	No. Rings	Seal Cage Width	Gland Stud Size	Gland studs quantity	Bolt Circle Diameter	Distance to First Obstruction
4T	54.0 (2.13)	73.0 (2.87)	71.9 (2.83)	9.7 (0.38)	5	19.1 (0.75)	1/2-13NC	2	130.1 (5.12)	69.9 (2.75)
5T	70.0 (2.75)	95.3 (3.75)	95.3 (3.75)	12.7 (0.50)	5	25.4 (1.00)	5/8-11NC	2	154.9 (6.10)	85.9 (3.38)
6A	89.0 (3.50)	114.3 (4.50)	95.3 (3.75)	12.7 (0.50)	5	25.4 (1.00)	5/8-11NC	2	175.0 (6.89)	84.3 (3.32)
7L	114.0 (4.50)	139.7 (5.50)	95.3 (3.75)	12.7 (0.50)	5	25.4 (1.00)	3/4-10NC	2	190.5 (7.50)	88.9 (3.50)
7H (except 16 MN-19)	114.0 (4.50)	139.7 (5.50)	95.3 (3.75)	12.7 (0.50)	5	25.4 (1.00)	3/4-10NC	2	190.5 (7.50)	88.9 (3.50)
7H (16 MN-19)	127.0 (5.00)	158.7 (6.25)	117.3 (4.62)	15.8 (0.62)	5	31.8 (1.25)	3/4-10NC	2	215.9 (8.15)	90.4 (3.56)
8L	127.0 (5.00)	158.7 (6.25)	117.3 (4.62)	15.8 (0.62)	5	31.8 (1.25)	3/4-10NC	2	215.9 (8.15)	104.7 (4.12)
8H	127.0 (5.00)	158.7 (6.25)	117.3 (4.62)	15.8 (0.62)	5	31.8 (1.25)	3/4-10NC	2	215.9 (8.15)	104.7 (4.12)
8HA	149.3 (5.88)	187.5 (7.38)	142.7 (5.62)	19.1 (0.75)	5	38.1 (1.50)	7/8-9NC	2	264.2 (10.40)	127.0 (5.00)
9H	179.5 (7.07)	217.5 (8.56)	142.8 (5.62)	19.1 (0.75)	5	38.1 (1.50)	7/8-9NC	2	298.2 (11.74)	127.0 (5.00)
9HA	209.3 (8.24)	248.0 (9.76)	142.8 (5.62)	19.1 (0.75)	5	38.1 (1.50)	7/8-9NC	2	336.0 (13.23)	131.6 (5.18)

- (1) O.D. Sleeve tolerance is +0.00 mm/-0.13 mm (+0.000 in. /-0.005 in.) for all frames except 4T and 5T that are + 0.00 mm/-0.05 in. (+0.000 mm/-0.002 in.)
- (2) I.D. Box tolerance is +0.00 mm/-0.13 mm (+0.000 in. /-0.005 in.) for all frames except 4T and 5T which are + 0.05 mm/-0.00 mm (+0.002 in./-0.000 in.)

### 6.1.9 Maintenance of mechanical seal

The following instruction, if adhered to, will help to assure a long trouble free service life for the mechanical seal.

Most seals can be installed in a standard stuffing box, therefore in an emergency, packing with the addition of a seal cage and packing gland may be utilized. Compare your seal installation drawing to the "Stuffing Box Data" in section 6.1.8.1

#### 6.1.9.1 General instructions

- Be sure to read all seal instructions before installing the seal.
- A mechanical seal is a precision product. To ensure satisfactory operation, exercise extreme care to avoid scratching or marring the lapped seal faces.



Rotary to stationary seal faces are lapped to within millionths of an inch in flatness. It is therefore important to avoid grasping the rotary seal and compressing it against the spring, which due to uneven loading, may cause excessive seal face distortion and leakage upon installation.

#### 6.1.9.2 Preparing the pump

- After assembling the bearing frame, shaft sleeve and stuffing box, check the concentricity between the bore of stuffing box and shaft sleeve. The concentricity should not exceed the Seal Manufacturer's tolerances. Also check the sleeve diameter and stuffing box bore dimensions to see that they agree with those shown on seal installation drawing.
- Check that the face of the stuffing box is square with the shaft sleeve to within the Seal Manufacturer's tolerances. This surface must be smooth and flat to ensure good sealing between the mechanical seal gland and stuffing box face.
- Mount the rotating assembly in the pump and adjust the wearing ring gap. Remove the rotating assembly from the pump and scribe a line on the shaft sleeve to mark the location of the stuffing box face in relation to the shaft sleeve. Remove the stuffing box head.

#### Note:

The wearing gap must be set before the mechanical seal is mounted since setting the gap relocates the shaft sleeve in relation to the stuffing box head by as much as 6.35 mm (0.25 in.). If the wearing gap is reset, then the mechanical seal must be remounted.



Check that the sleeve is free of pits, burrs or sharp edges to prevent cutting or improper sealing of the rotating O-rings.

**6.1.9.3 Installing the seal**

Refer to the manufacturer's instructions for seal installation.

**6.1.9.4 Before starting the unit.**

Check and make certain that the gland flushing line) is clean (and also, return line if it is a double seal, open and free of any obstruction that may interfere with circulation of clear flushing liquid for the seal.

Before start up bleed all air from the seal cavity. This is necessary to ensure a clean liquid environment for effective seal operation

**6.1.10 Re-lubrication**

Lubricant and bearing temperature analysis can be useful in optimizing lubricant change intervals. In general the following is recommended.

**6.1.10.1 Oil lubrication**

**CAUTION** Maintaining the correct oil level is very important. If a sight glass has been fitted then regular checks should be made to ensure the level is maintained at the center of the glass window.

Refer to section 5. for methods of oil fill, oil grade recommendations and for the schedule and temperature limits.

**6.1.10.2 Grease lubrication**

**CAUTION** See section 5.2.5 for grease recommendations. Re-grease via grease nipples depending on the severity of the application.

- a) It is important not to under or over grease the bearings as this will lead to over heating and premature failure. Grease lubricated bearing housings have grease nipples fitted in the bearing covers.
- b) Connect grease gun to the nipple.

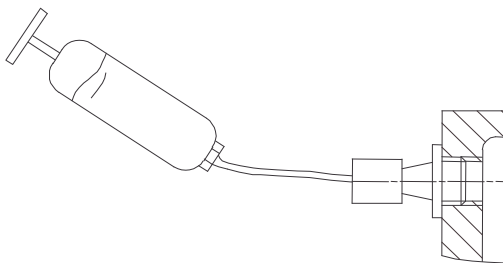

- c) Press grease into the bearing housing until the first signs of it appear in the gap between the housing and shaft, then stop greasing.
- d) The maximum allowable operating temperatures for anti friction bearings will vary from unit to unit, depending on ambient and fluid temperature. The rise above ambient should not normally exceed 55 °C (131 °F) or a combined maximum of 95 °C (204 °F).
- e) A continuously rising temperature or an abrupt temperature rise indicates a problem. If these symptoms occur, stop the pump immediately and investigate the cause.

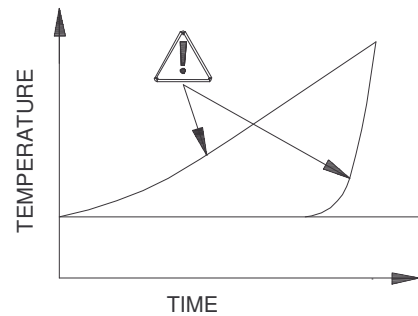

**6.1.10.3 Grease change**

**CAUTION** if Kerosene is used to clean the bearings make sure that the required safety measures are to be in place while handling this liquid fuel for cleaning (See Fuel supplier/ manufacturer's Material Safety Data Sheets for provided flash and flame temperatures).

- a) Remove the bearing housing from the rotor assembly.
- b) Brush the bearing housing with hot oil (at about 94° to 115°C (200° to 240°F) or other non-toxic solvent.
- c) Clean and flush out the housing with a light mineral oil.

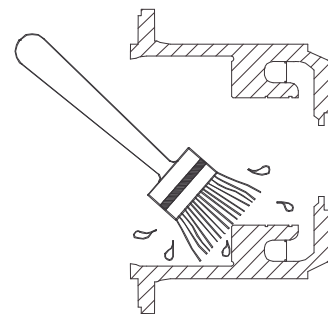

- d) Do not use waste oil to clean the housing.

**6.1.10.4 To clean the bearings**

- a) Wipe off as much grease as possible with a clean lint-free cloth.
- b) Brush bearings with hot oil or non-toxic solvent 80 to 95 °C (180 to 200 °F ) while gently spinning the outer bearing ring.
- c) Spin each roller to ensure that it is clean

**6.1.10.5 To remove badly oxidized grease**

- a) Support the rotor in a vertical position and immerse the bearing in hot kerosene or a mixture of alcohol and light mineral solvent.
- b) Gently spin the bearing outer ring.
- c) Dry and reflush the bearing with clean light oil.

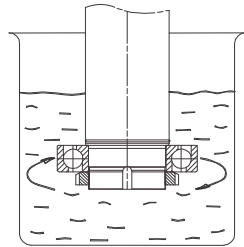

- d) It is important not to under or over grease the bearings as this will lead to over heating and premature failure. It is recommended that the bearings be filled with grease using a suitable spatula. In addition the housings should be no more than half filled.

**6.1.11 Mechanical seals**

No adjustment is possible. When leakage reaches an unacceptable level the seal will need replacement.

**6.1.12 Gland packing**

The stuffing box split gland can be completely removed for re-packing or to enable the addition of extra rings of packing.

The stuffing box is normally supplied with a lantern ring to enable a clean or pressurized flush to the center of the packing. If not required, this can be replaced by an extra 2 rings of packing.

There must always be a small leakage, normally a minimum of 30~60 drops per minute is required depending upon the sleeve diameter.

**6.2 Spare parts**

**6.2.1 Ordering of spares**

Flowserve keep records of all pumps that have been supplied. When ordering spares the following information should be quoted:

- a) Pump serial number.
- b) Pump size.
- c) Part name – taken from section 8.
- d) Part number – taken from section 8.
- e) Number of parts required.

The pump size and serial number are shown on the pump nameplate. To ensure continued satisfactory operation, replacement parts to the original design specification should be obtained from Flowserve.

Any change to the original design specification (modification or use of a non-standard part) will invalidate the pump's safety certification.

**6.2.2 Service parts**

The severity of the condition of service, the extent to which repairs can be carried out in the field, and the number of units installed will determine, to a great extent, the minimum number of service parts that should be carried in stock at the installation site. It is suggested, as insurance against delays, that service parts be purchased at the time the pump order is placed or as soon after receiving the pump as possible.

A suggested spare parts list (priced if desired) can be furnished upon request.

**6.2.3 Returning parts**

All material returned to the factory must have a returned material (RM) tag attached. Consult the nearest Flowserve sales office or OEM factory for shipping instructions and "RM" tags. Unnecessary delays are avoided when parts or equipment are returned to the proper factory using the correct procedure.

- a) When contacting the sales office or factory for return authorization, list the material to be returned and the reasons for returning it.
- b) On receipt of the "RM" tags, be sure to check the part name, the part number, the quantity of parts involved, and the serial number of the equipment.
- c) The "RM" tag must accompany the material shipped. Enclose it in the shipping container or attach it to the part being returned.

- d) In cases where more than one part or box is returned, individually print or stencil your name, the part name, and the "RM" tag number on each part or box. Then attach the "RM" tag to one of the parts or boxes. This will facilitate quick identification.

Articles being returned should be carefully packed to prevent damage from handling or from exposure to the weather.

**6.2.4 Storage of spares**

Spares should be stored in a clean dry area away from vibration. Inspection and re-treatment of metallic surfaces (if necessary) with preservative is recommended at 6 monthly intervals.

**6.3 Suggested spares and consumable items**

**For start up purposes:**

- 1 - complete set of gland packing
- 1 - shaft sleeves
- 1 - set of gaskets and seals  
(optional: 2 - mechanical seal kits)

**For 2 years operation:**

- 1 - set of bearings (line and thrust)
- 2 - sets of gland packing
- 2 - shaft sleeves
- 2 - sets of gaskets and seals
- 2 - lantern rings
- 2 - casing wear rings  
(optional: 2 - mechanical seals  
2 - impeller wear rings)

**For 4 years operation:**

- 1 - set of bearings (line and thrust)
- 2 - sets of gland packing
- 2 - shaft sleeves
- 2 - sets of gaskets and seals
- 2 - lantern rings
- 2 - casing wear rings
- 1 - impeller  
(optional: 2 - mechanical seals, 2 - impeller wear rings)

**6.4 Tools required**

No special tools are needed to maintain this pump. Most tools are readily available in standard tool kits, and dependent on pump size:

- Open ended spanners (wrenches)
- Socket spanners (wrenches)
- Allen keys
- Range of screwdrivers
- Soft mallet

For some specialized equipment:

- Bearing induction heater/Oven
- Dial test indicator
- C-spanner (wrench) - for removing shaft nut.  
(If difficulties in sourcing are encountered, consult Flowserve.)

**6.5 Fastener torques**

The following table is provided as a guide for the proper assembly of Grade (SAE) 2 fasteners.

Torques are for lubricated threads. Lubricate the fastener and tapped hole threads and the underside of the bolt heads and nuts before assembly.

**Note:**

DO NOT lubricate threads that require the application of Loctite thread locking compound.

Bolt size mm (in.)	Torque N-m (lb-ft)
M 6 (1/4)	8 (6)
M 8 (5/16)	16 (12)
M 10 (3/8)	28.5 (21)
M 12 (7/16)	47.5 (35)
M 14 (1/2)	70 (50)
*(9/16)	95 (70)
M 16 (5/8)	135 (100)
M 20 (3/4)	235 (175)
M 24 (7/8)	205 (150)
M 27 (1)	305 (225)
M 30 (1-1/8)	435 (320)
<b>M 33**</b> (1-1/4)	610 (450)
M 36 (1-3/8)	800 (590)
<b>M 39**</b> (1-1/2)	1070 (790)

\*No metric equivalent available

\*\* Nearest size equivalent in metric (non-std)

**Note:**

For assembly of a joint always finger tighten all nuts or bolts first. Then cross-tighten evenly in about three equal steps to develop final torque values.

**6.6 Renewal clearances.**

As wear takes place between the impeller and casing ring the overall efficiency of the pump set will decrease. To maintain optimum efficiency it is recommended that rings are replaced and the impeller refurbished. The clearance dimensions depends on pump size. Contact Flowserve representative for the service advise.

## 6.7 Disassembly



Refer to section 1.6, *Safety*, before dismantling the pump.



Before dismantling the pump for overhaul, ensure genuine Flowserve replacement parts are available. Refer to sectional drawings for part numbers and their identification.

### 6.7.1 Preliminary dismantling procedure

- a) Isolate motor and lock off electrical supply in accordance with local regulations.
- b) Isolate suction and discharge valves.
- c) Remove coupling guards and disconnect the U shaft.
- d) Drain pump casing. Remove any auxiliary piping if applicable.

### 6.7.2 Pump dismantling procedure

Care must be exercised in the dismantling operation. Close the suction and discharge valves and drain liquid from the casing. For convenience at re-assembly, lay out all parts in the order in which they are removed. Protect all machined faces against metal to metal contact and corrosion. Proceed as follows referencing the pump sectional drawing.

- a) Disconnect the intermediate shaft section closest to the pump. If possible, swing the shaft section out to the side and secure.
- b) Unbolt the stuffing box head from the casing.
- c) Draw out the rotating assembly complete with the stuffing box head, bearing housing, impeller, etc. Exercised care in slinging and handling the unit.
- d) Remove the impeller nut set screw and the impeller nut. The set screw was mounted using Loctite 271 or equivalent and may require heating to 200 °C (400 °F) for removal. A standard square bar will fit the square hole provided in the impeller nut.
- e) Remove the impeller and impeller key.
- f) Remove the packing gland. If the pump is equipped with a mechanical seal unbolt the gland.
- g) Unbolt and remove the bearing frame from stuffing box head. The packing and seal cage halves may be removed at this time. Remove the mechanical seal if so equipped.
- h) Remove the shaft sleeve only if necessary; see Maintenance of Shaft and Shaft Sleeve.
- i) Remove pump coupling half. Do not hammer to remove.
- j) Remove the upper and lower outside seal rings.

- k) Remove the upper and lower bearing housing covers with their respective seals. If a bent shaft is suspected, the shaft should be checked for runout at this time. The maximum permissible runout is 0.002" (0.051mm) TIR at the bearing, coupling, sleeve, and impeller turns.
- l) Disengage the thrust bearing lock washer tab from its locknut. Unscrew the thrust bearing locknut and remove the lock washer and bearing washer.
- m) Remove the shaft toward the impeller end. The thrust bearing will be pushed off the shaft by this movement.
- n) For further removal of bearings refer to Maintenance of Bearings.

Carefully examine all individual parts, important joints, and all wearing surfaces as the pump and rotor are dismantled. As a general rule, regardless of the performance of the unit, bearings and parts appreciably worn should be renewed if it is not intended to examine the pump again until the next overhaul period.

### 6.7.3 Bearing installation and removal

Anti-friction bearing cones (inner race) are usually pressed or shrunk onto the shaft. The cups (outer races) are usually pressed or shrunk into the bearing housing. When mounting bearings it is important that the proper fit is maintained.

When a pulling device is used to remove bearings from the shaft, the pulling jaws or fingers should be located on the bearing cone. When other parts do not interfere, the bearing cone may be supported by a split ring and the shaft pressed out using an arbor press. The bearing cups can similarly be pulled out of the housing.

There are two methods for mounting a bearing on the pump shaft:

- a) Heating the bearing to expand the cone and shrinking it on the shaft.
- b) Pressing the bearing onto the shaft.

The method (a) is preferred over the method (b).

Heat the bearing in an oil bath or electric oven to a uniform temperature of 120 °C (250 °F). When heated, quickly mount it on the shaft. If the alternate method is used, apply force by means of an arbor press; see detail below. Use a tubular sleeve, ring, or small blocks of equal thickness to apply the force to the cone (inner race).

In forcing a bearing onto a shaft, be careful that the cone is never cocked.

Check the position of the bearing on the shaft with a feeler gauge to ensure it is pressing firmly against the shaft shoulder.

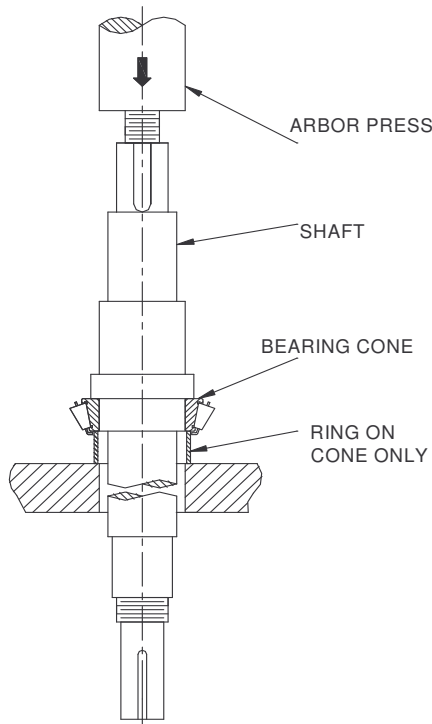

Mounting a bearing cone on a shaft using an arbor press

**6.7.4 Bearing end play adjustment**

The initial end play will usually be 0.13 to 0.38 mm. (0.005 to 0.015 in.). Adjust to the recommended end play shown in section 6.7.5 by tightening the thrust bearing nut as necessary and repeating the procedure below to check the end play. If the end play becomes less than the recommended endplay, the thrust bearing nut must be loosened and the thrust bearing cone backed off by pressing if necessary (due to likelihood of being an interference fit). **DO NOT** exceed the static rating of the thrust bearing if pressing is necessary. The entire rotating element (bearing frame, stuffing box head, and impeller) should be assembled before the bearing endplay is set. The assembly weight is necessary to properly set the bearing endplay.

- a) Mount a dial indicator on the thrust end of the housing with its arm resting on top of the pump shaft.
- b) With the bearing assembly supported vertically on the impeller, oscillate the frame to allow the line bearing rollers to fully seat. If this is not done false readings will be obtained. Record the dial indicator reading.
- c) Now lift the bearing frame and oscillate the shaft to allow the thrust bearing rollers to fully seat. Record the dial indicator reading.
- d) The bearing end play is the difference in readings in items (b) and (c) above. Repeat steps (b) and (c) above to assure measurement consistency.
- e) Once the endplay is set, bend over the closest lock washer tab into one of the thrust bearing locknut slots. This will secure the bearing locknut in place.

### 6.7.5 Bearing end play

Bearing Frame	Recommended end play mm (in.)	End play adjustment		Thrust bearing static load rating Kg (lb.)
		mm (in.)	mm (in.)	
		With full tang movement	With 1/4 tang movement	
4T	0.03-0.10 (0.002 - 0.004)	0.08 (0.0033)	0.02 (0.0008)	2250 (4970)
5T	0.03-0.10 (0.002 - 0.004)	0.08 (0.0033)	0.02 (0.0008)	5580 (12300)
6	0.03-0.10 (0.002 - 0.004)	0.07 (0.0028)	0.02 (0.0008)	6220 (13700)
6A	0.03-0.10 (0.002 - 0.004)	0.07 (0.0028)	0.02 (0.0008)	8850 (19500)
7L	0.03-0.10 (0.002 - 0.004)	0.11 (0.0044)	0.03 (0.0011)	6560 (14470)
7H	0.03-0.10 (0.002 - 0.004)	0.11 (0.0044)	0.03 (0.0011)	7200 (15880)
8L	0.03-0.10 (0.002 - 0.004)	0.11 (0.0044)	0.03 (0.0011)	10240 (22580)
8H	0.03-0.10	0.11	0.03	15950
8HA	(0.002 - 0.004)	(0.0044)	(0.0011)	(35170)
9H	0.08-0.16	0.17	0.04	23550
9HA	(0.003 - 0.005)	(0.0066)	(0.0016)	(51920)

### 6.8 Examination of parts



Used parts must be inspected before assembly to ensure the pump will subsequently run properly.

In particular, fault diagnosis is essential to enhance pump and plant reliability.

#### 6.8.1 Casing, seal housing and impeller

- a) Inspect for excessive wear, pitting, corrosion, erosion or damage and any sealing surface irregularities.
- b) Replace as necessary.

#### 6.8.2 Shaft and sleeve (if fitted)

Replace if grooved, pitted or worn.

#### 6.8.3 Gaskets and O-rings

After dismantling, discard and replace.

### 6.8.4 Bearings

- a) It is recommended that bearings are not re-used after any removal from the shaft.
- b) The plain liquid lubricated bearings may be re-used if both the bearing bush and bearing sleeve show no sign of wear, grooving or corrosion attack. (It is recommended that both the bush and sleeve are replaced at the same time.)

### 6.8.5 Bearing isolators, or lip seals (if fitted)

- a) The lubricant, bearings and bearing housing seals are to be inspected for contamination and damage. If oil bath lubrication is utilized, these provide useful information on operating conditions within the bearing housing.
- b) If bearing damage is not due to normal wear and the lubricant contains adverse contaminants, the cause should be corrected before the pump is returned to service.
- c) Lip seals and bearing isolators should be inspected for damage but are normally non-wearing parts and can be re-used.
- d) Bearing seals are not totally leak free devices. Oil from these may cause staining adjacent to the bearings.

## 6.9 Assembly

To assemble the pump consult the sectional drawings, see section 8, *Parts list and drawings*.

Ensure threads, gasket and O-ring mating faces are clean. Apply thread sealant to non-face sealing pipe thread fittings.

### 6.9.1 Bearing housing assembly - Grease lubricated

- a) Be sure the shoulders where the bearings seat, are free of burrs and contaminants.
- b) Mount the grease retainers into their respective bores [51, 51A]. Prick punch the outer diameter at two places 180° apart to secure them to the bearing frame, if necessary. Do not remove the grease retainers on disassembly unless they are to be replaced.
- c) Mount the bearing cups (outer races) [16,18] into their respective bearing housing bores (either chill or press in to install). Be sure the cups seat against the bearing housing shoulders.
- d) Assemble the line bearing cone [16] on the shaft [6] (heat or press to install). See section 6.7.3 for details.
- e) Install the shaft [6] with the thoroughly grease-packed line bearing cone fitted, through the housing and support the assembly vertically (thrust end up).
- f) Heat the thrust-bearing cone to approximately 95 °C (200 °F) and assemble it on the shaft together with the bearing washer [22B], lock washer [22A], and locknut [22]. Hand tighten the nut.
- g) Assemble the line bearing inner seal [40A], line bearing cover [35] and outer seal [40A]. Adjust the bearing endplay; See Bearing End Play adjustment in section 6.7.4.
- h) Pack the thrust bearing [18] with grease.
- i) Install the thrust bearing inside seal [49], cover [37] and outside seal [40].

**Note:** The impeller set screw and wearing ring screws are locked in place using Loctite 271 or equivalent. The shaft sleeve is mounted using Loctite RC/680 or equivalent. Mating surfaces must be thoroughly cleaned and dry prior to application of the adhesive compound.

### 6.9.1.1 Impeller nut

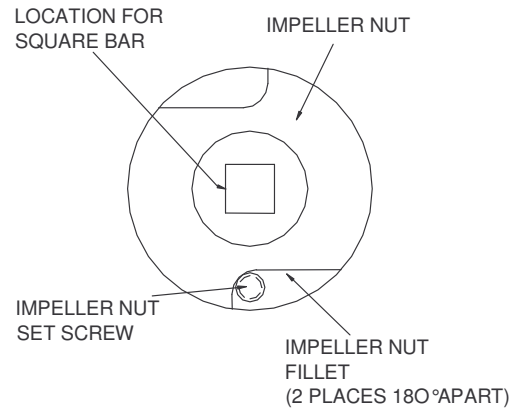

**Note:** Grease all the contact seal lips before installation. Position the outside seals (line and thrust bearing) with minimum lip contact to the covers. Excessive lip pressure will result in the seal rings running hot and premature seal ring failure.

### 6.9.2 Pump assembly

To assemble the pump, reverse the dismantling instructions previously described.

- a) Follow the bearing housing assembly, wearing ring, packing, and shaft sleeve assembly instructions. Torque all assembly bolts and screws to the recommended torque values listed in section 6.5.
- b) If the unit is equipped with a mechanical seal, refer to the mechanical seal manufacturer's instructions for installation.
- c) Install the rotating assembly in the casing [1].
- d) Check that the impeller [2] turns freely and adjust the wearing ring gap. See section 6.1.6 for details.
- e) Align the pump with the motor; see Section 4.5.
- f) Install the packing and seal cage; see Section 6.1.8.
- g) Add lubricant as described in Section 5.2.

## 7 FAULTS; CAUSES AND REMEDIES

### FAULT SYMPTOM

Pump overheats and seizes															
↓	Bearings have short life														
↓	Pump vibrates or is noisy														
↓	Mechanical seal/gland has short life														
↓	Mechanical seal/gland leaks excessively														
↓	Pump requires excessive power														
↓	Pump loses prime after starting														
↓	Insufficient discharge pressure developed														
↓	Insufficient capacity delivered														
↓	Pump does not deliver liquid														
													PROBABLE CAUSES	POSSIBLE REMEDIES	
<b>A. System troubles</b>															
●													●	Pump not primed.	Check and fill with liquid completely. Vent and/or prime.
	●												●	Pump or suction pipe not completely filled with liquid or valves not fully open.	
	●												●	Suction lift too high or level too low.	Check $NPSH_A > NPSH_R$ , proper submergence, losses at inlet and fittings.
●	●												●	Insufficient margin between suction pressure and vapor pressure.	
													●	Excessive amount of air or gas in liquid.	Check and purge pipes and system.
													●	Air or vapor pocket in suction line.	Check suction line design for vapor pockets.
													●	Air leaks into suction line.	Check suction pipe is airtight.
													●	Air leaks into pump through mechanical seal, sleeve joints, casing joint or pipe plugs.	Check and replace faulty parts. Refer to Seal User Instructions/Consult Flowserve.
	●												●	Impeller, casing piping partially /fully clogged.	Investigate replacing the valve.
	●												●	Inlet of suction pipe insufficiently submerged.	Clean /open valve as required.
	●												●	Inlet of suction pipe insufficiently submerged.	Check out system design.
													●	Speed too low.	Consult Flowserve.
													●	Speed too high.	Consult Flowserve
													●	Total head of system higher than differential head of pump.	Check system losses. Remedy or Consult Flowserve.
													●	Total head of system lower than pump design head.	
													●	Specific gravity of liquid different from design.	Check and Consult Flowserve.
													●	Viscosity of liquid differs from that for which designed.	
●	●													Operation at very low capacity.	Measure value and check minimum permitted. Remedy or Consult Flowserve.
	●	●												Operation at high capacity.	Measure value and check maximum permitted. Remedy or Consult Flowserve.
<b>B. Mechanical troubles</b>															
●	●	●	●	●	●									Misalignment due to pipe strain.	Check the flange connections and eliminate strains using elastic couplings or a method permitted.
			●											Improperly designed foundation and/or critical frequency of the system excited.	Check setting of baseplate: tighten, adjust, grout base as required. Resonance tests
	●	●	●	●	●									Shaft bent.	Check shaft runouts are within acceptable values Consult Flowserve.
●	●	●												Rotating part rubbing on stationary part internally.	Check and Consult Flowserve, if necessary.
●	●	●	●	●	●									Bearings worn	Replace bearings.





## 8 PARTS LIST AND DRAWINGS

### 8.1 MNF cross section and parts list (Typical- Grease filled)

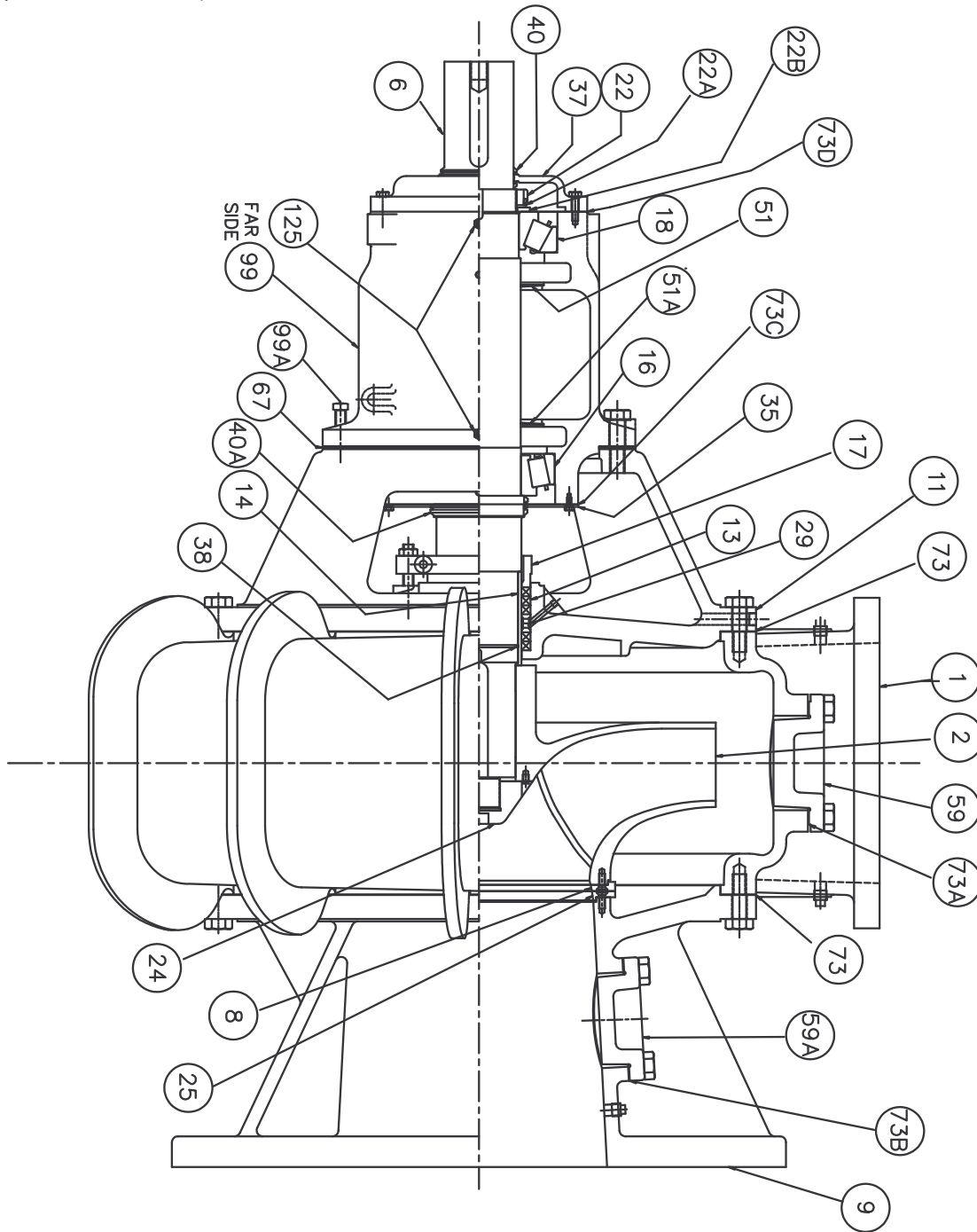

**Note:**

The sectional drawing provided in this section are typical representation of MNF pump with grease lubrication. The details shown here may not reflect the specifics of the pump that has been purchased or ordered. You may purchase order specific cross sectional drawings separately. Please contact Flowserve for pricing and ordering information on such documentation.

**8.1.1 Parts list MNF (See section 8.1 for details)**

STATIONARY PARTS		
Ref No	No required	Description
1	1	Casing
9	1	Suction head
11	1	Stuffing box head
13	5 rings	Packing
17	1	Split gland
25	1	Suction head wearing ring
29	1	Seal cage split
35	1	Line bearing cover
37	1	Thrust bearing cover
51		Grease retainer- out board
51A	1	Grease retainer inboard
59	1	Casing hand hole cover
59A	1	Suction head hand-hole cover
67	1 Set	Adjusting shims
73	2	Casing gasket
73A	1	Casing hand hole cover gasket
73B	1	Suction head hand hole cover gasket
73C	1	Line bearing cover gasket
73D	1	Thrust bearing cover gasket
99	1	Bearing frame
99A	2	Adjusting bolt
125	2	Grease fitting

ROTATING PARTS		
Ref No	No required	Description
2	1	Impeller
6	1	Pump shaft
8	1	Impeller wearing ring
14	1	Shaft sleeve
16	1	Line bearing
18	1	Thrust bearing
22	1	Bearing locknut
22A	1	Bearing lock washer
22B	1	Bearing washer
24	1	Impeller nut
38	1	Shaft sleeve O ring
40	2	Seal ring (thrust)
40A	2	Seal ring (Line)



**8.2.1 MNC parts list (See section 8.2 for details)**

STATIONARY PARTS		
Ref No	No required	Description
1	1	Casing
9	1	Suction head
11	1	Stuffing box head
13	5 RINGS	Packing
17	1	Split gland
25	1	Suction head wearing ring
29	1	Seal cage split
35	1	Line bearing cover
37	1	Thrust bearing cover
51		Grease retainer- out board
51A	1	Grease retainer inboard
59	1	Casing hand hole cover
59A	1	Suction head hand-hole cover
67	1 SET	Adjusting shims
73	2	Casing gasket
73A	1	Casing hand hole cover gasket
73B	1	Suction head hand hole cover gasket
73C	1	Line bearing cover gasket
73D	1	Thrust bearing cover gasket
99	1	Bearing frame
99A	2	Adjusting bolt
125	2	Grease fitting

ROTATING PARTS		
Ref No	No required	Description
2	1	Impeller
6	1	Pump shaft
8	1	Impeller wearing ring
14	1	Shaft sleeve
16	1	Line bearing
18	1	Thrust bearing
22	1	Bearing locknut
22A	1	Bearing lock-washer
22B	1	Bearing washer
24	1	Impeller nut
40	2	Seal ring (thrust)
40A	2	Seal ring (Line)

**8.3 General arrangement drawing**

The typical general arrangement drawing and any specific drawings required by the contract will be sent to the Purchaser separately unless the contract specifically calls for these to be included into the User Instructions. If these drawings are sent separately, the Purchaser must retain them with the User Instructions.

**9 CERTIFICATION**

Certificates determined from the Contract requirements are provided with these Instructions where applicable. Examples are certificates for CE marking, ATEX marking etc. If required, copies of other certificates sent separately to the Purchaser should be obtained from the Purchaser for retention with these User Instructions.

**10 OTHER RELEVANT DOCUMENTATION AND MANUALS**

**10.1 Supplementary user instructions**

Supplementary instructions such as for a driver, instrumentation, controller, seals, sealant system etc are provided as separate documents in their original format. If further copies of these are required they should be obtained from the supplier for retention with these User Instructions.

**10.2 Change notes**

If any changes, agreed with Flowserve Pump Division, are made to the product after its supply, a record of the details should be maintained with these Use Instructions.

## FLOWSERVE REGIONAL SALES OFFICES:

### USA and Canada

Flowserve Corporation (Head Quarters)  
5215 North O' Connor Blvd. Suite 2300  
Irving, TX 75039, USA

Tel +1 972 443 6500  
Toll free 800 728 PUMP (7867)  
Fax +1 972 443 6800

### Latin America & Caribbean

Flowserve Corporation (Pump Division)  
6840 Wynnwood Lane  
Houston, Texas 7708, USA

Tel +1 713 803 4434  
Fax +1 713 803 4497

### Europe, Middle East & Africa

Flowserve Limited (Pump Division)  
Harley House, 94 Hare Lane  
Claygate, Esher, Surrey KT10 0RB  
United Kingdom

Tel +44 (0)1372 463 700  
Fax +44 (0)1372 460 190

### Asia Pacific

Flowserve Pte Ltd (Pump Division)  
200 Pandan Loop, # 06-03/04  
Pantech 21, Singapore 128388

Tel +65 775 3003  
Fax +65 779 4607

Visit our web site at: [www.flowserve.com](http://www.flowserve.com)

***Your Flowserve factory contact:***

Flowserve Pump Division  
5310 Taneytown Pike, PO Box 91  
Taneytown, MD 21787-0091, USA

Customer Service-PH: +1 (410) 756 2602  
Customer Service FAX: +1 (410) 756 2615  
Parts inquiry/Order PH: +1 (800) 526 3569

***Your local Flowserve representative:***

*To find your local Flowserve representative, please use the Sales Support Locator System found at [www.flowserve.com](http://www.flowserve.com)*