

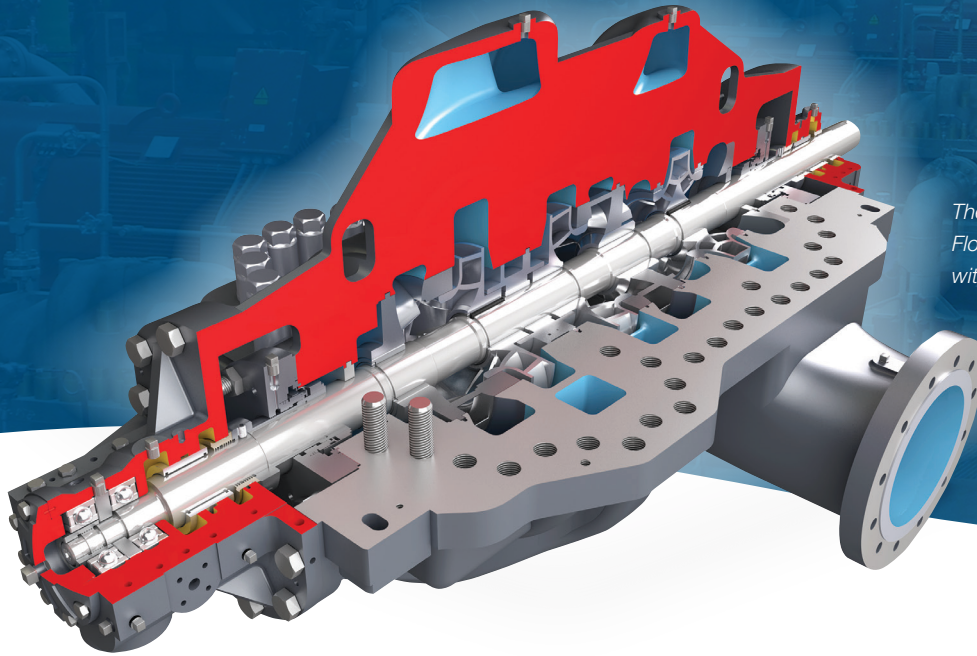

DMX-RO

High-efficiency membrane feed pump for reverse osmosis desalination



The DMX-RO is based on the widely used Flowserve DMX pump, which is fully compliant with ISO 13709/API 610 (BB3), latest edition.

Minimize operating expenses and extend mean time between repair

Flowserve DMX-RO high-efficiency membrane feed pumps are engineered using the latest technologies and materials to provide long-lasting, efficient operation in reverse osmosis applications.

The DMX-RO is built for high-pressure, heavy-duty membrane feed services used typically in SWRO applications. DMX-RO pump hydraulics are designed with advanced computational fluid dynamics to provide best system performance and minimize operating expenses. The pump's comprehensive hydraulic range permits precise selection to deliver best hydraulic fit, operating efficiency and stability, all of which help to extend mean time between repair. Corrosion-resistant materials ensure long performance life without degradation.

Features and benefits

Axially split casing design simplifies maintenance and reduces downtime. Pump internals are easily accessed via the top casing so the bottom casing and piping connections are not disturbed.

Casing and internal material combinations selected to meet service requirements. Available materials of construction include carbon steel, chromium steel, austenitic stainless steels and super duplex stainless steels.

Nozzles are integrated with the lower half casing and designed to handle external forces and moments equal or in excess of ISO/API specified figures.

Variety of impellers and stage configurations are available.

Cap nuts are arranged on the top half casing parting flange, allowing easy casing removal for rotor inspection and maintenance.

Axially split center bushing facilitates replacement while simplifying inspection and dynamic balancing of the rotor without dismantling.

Continuous cross-over design to optimize internal losses, increase efficiency and support hydraulic balance.

Double volute construction supports radial thrust balancing.

Optimized impeller wear part clearances and careful material selection improve efficiency and maximize mean time between repair.

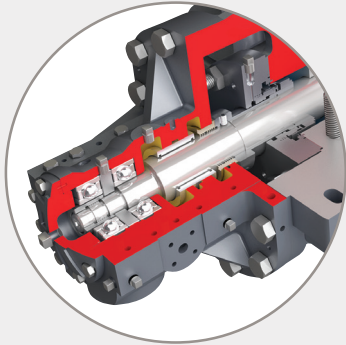

ISO 21049/API 682 seal chamber

Compliant with ISO 21049/API 682 dimensional criteria, this seal chamber design allows for installation of different cartridge types. It provides longer life and eases maintenance.

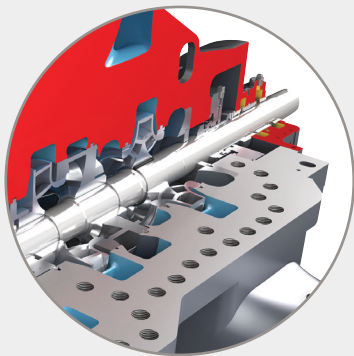

Single- or double-suction, first-stage impellers

First-stage impellers may be single- or double-suction design, depending upon NPSH available. This ensures optimal suction performance for each application.

Optional instrumentation

The DMX-RO pump is compatible with advanced internet of things (IoT) solutions such as RedRaven condition monitoring from Flowserve. Flowserve RedRaven IoT solutions give you the insights and tools you need to monitor, analyze and predict equipment performance — so you can improve pump uptime while reducing maintenance and energy costs.



Ask your Flowserve representative about optional RedRaven IoT monitoring packages or visit flowserve.com/iot to learn more.



Available pump packages

Pump packages are provided to specification and may include lube oil piping, seal systems, cooling piping Plan 11, monitoring instruments and drive train mounting.

Shaft options

The DMX-RO is available with an optional double extension for connecting to hydraulic turbines. Additionally, special shaft end machining is available for hydraulic fitted couplings.

Operating parameters

- Flows to 2,950 m³/h (13,000 gpm)
- Heads to 850 m (2,789 ft)
- Pressures to 90 bar (1,305 psi)
- Temperatures to 50°C (34°F)
- Speeds to 3,600 rpm

Materials of construction

Component	Material
Casing	Super duplex stainless steel
Impeller	Super duplex stainless steel
Shaft	Super duplex stainless steel
Wear rings	Super duplex stainless steel with overlay; or non-metallic
Bearing housing	Carbon steel