

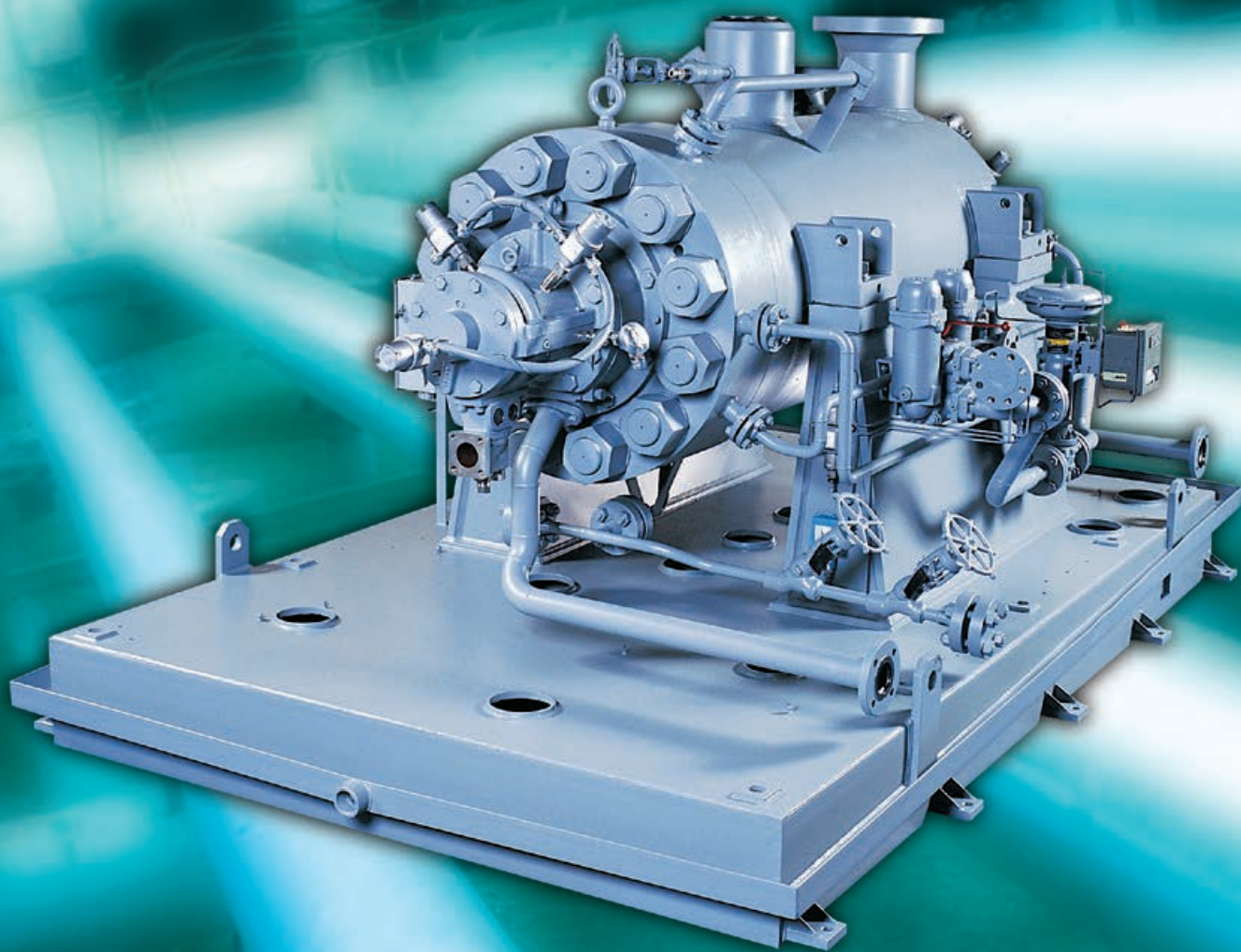

# *Utility Barrel Pumps Between Bearings, Multistage, Double Casing*

WXB, WNC, CSB, CHTA, HDB



*Experience In Motion*

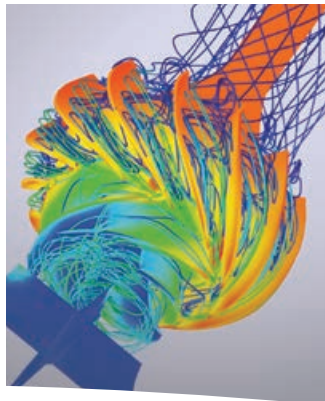

## ***Pump Supplier to the World***

*Flowserve is the driving force in the global industrial pump marketplace. No other pump company in the world has the depth or breadth of expertise in the successful application of pre-engineered, engineered, and special purpose pumps and systems.*

### ***Life Cycle Cost Solutions***

Flowserve provides pumping solutions that permit customers to reduce total life cycle costs and improve productivity, profitability and pumping system reliability.

### ***Market-Focused Customer Support***

Product and industry specialists develop effective proposals and solutions directed toward market and customer preferences. They offer technical advice and assistance throughout each stage of the product life cycle, beginning with the initial inquiry.

### ***Broad Product Lines***

Flowserve offers a wide range of complementary pump types, from pre-engineered process pumps to highly engineered and special purpose pumps and systems. Pumps are built to recognized global standards and customer specifications.

Pump designs include:

- Single-stage process
- Between bearings single-stage
- Between bearings multistage
- Vertical
- Submersible motor
- Positive displacement
- Nuclear
- Specialty

### ***Product Brands of Distinction***

*ACEC™*

*Aldrich™*

*Byron Jackson®*

*Calder™ Energy Recovery Devices*

*Cameron™*

*Durco®*

*Flowserve®*

*HALBERG™*

*IDP®*

*INNOMAG®*

*Lawrence Pumps®*

*Niigata Worthington™*

*Pacific®*

*Pleuger®*

*Scienco™*

*Sier-Bath®*

*SIHI®*

*TKL™*

*United Centrifugal®*

*Western Land Roller™*

*Wilson-Snyder®*

*Worthington®*

*Worthington Simpson™*



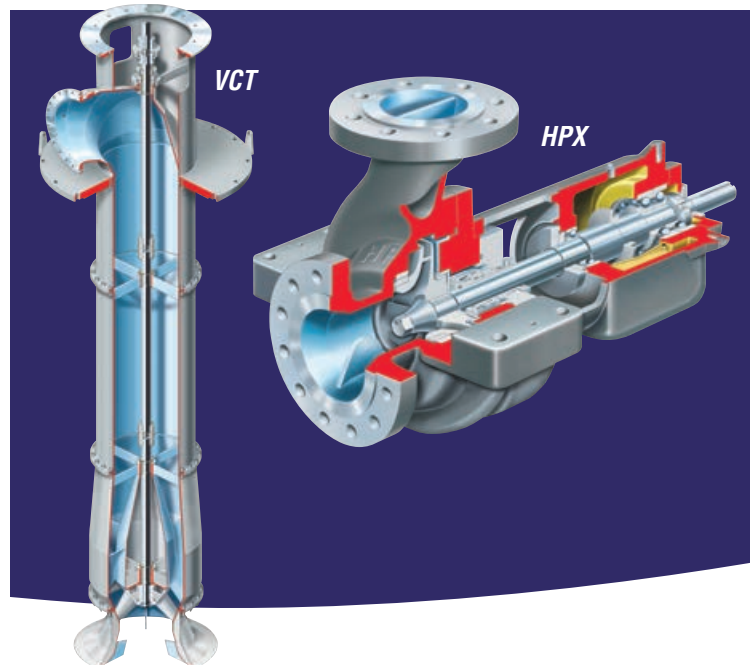

## Supplier of Choice to the Global Power Industry

With more than 200 years of technological and manufacturing leadership, Flowserve has unparalleled experience in the power-generation industry. This experience has produced many pump firsts, including:

- The highest pressure supercritical barrel type boiler feed pump
- The highest horsepower multistage boiler feed pump
- The first installation to have the booster and main pump on a common shaft

In addition to offering the most comprehensive selection of pumps of any manufacturer, Flowserve provides:

- Systems knowledge
- Hydraulic expertise
- Application know-how
- Leading-edge research programs
- Unmatched testing capabilities

### Boiler Feed Applications

- Subcritical steam cycle plants
- Supercritical steam cycle plants
- Combined cycle plants
- Nuclear steam-side services

### Complementary Pumps

Flowserve provides pumps for all power plant sources, including circulating water, condensate and raw water. Complementary pump designs include the following:

- Single casing, multistage segmental ring, diffuser pumps
- Single and multistage, axially split volute pumps
- Radially split, single- and two-stage pumps
- Vertical, wet-pit pumps
- API-type process pumps

### Table of Contents

Introduction . . . . .	3
A History of Leadership . . . . .	4
Performance Range . . . . .	5
WXB Pump . . . . .	6–7
WNC Pump . . . . .	8–9
CSB Pump . . . . .	10–11
CHTA Pump . . . . .	12–13
HDB Pump . . . . .	14–15
Options and Technical Information . . . . .	16–17
Mechanical Seal Solutions . . . . .	18

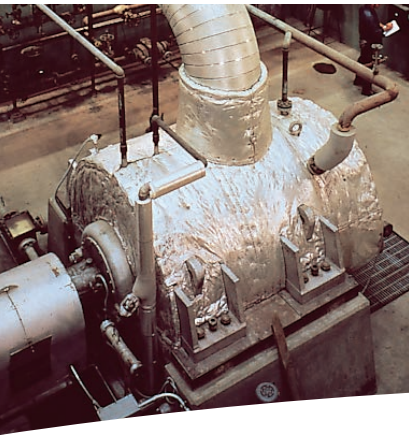

## Utility Industry Barrel Pumps

### Number One in Barrel Pump Technology

Offering both diffuser and volute designs, the Flowserve family of utility grade double case (barrel) pumps has evolved from the development of the world-famous and time-proven designs of these heritage brands:

- Byron Jackson Pumps
- Cameron Pumps
- IDP Pumps
- Pacific Pumps
- Worthington Pumps

Owing to this broad family of pumps, Flowserve is able to precisely and economically tailor a pump and driver package to all sizes and types of power-generating facilities.

### Ongoing Research and Development

Flowserve continues to improve the efficiency, reliability and serviceability of existing barrel pump models. It takes advantage of industry-spanning experience and best practices to develop leading-edge products and technologies. Recent advancements have been in the following areas:

- Shear ring sealing technology
- Cartridge-style rotor designs
- Metallurgical and laser-hardening techniques
- Computer modeling aids for pump diagnostics and selection

### Innovation and Leadership

Flowserve traces its roots in the power industry back to the development of the first direct-acting steam pump by Henry R. Worthington in 1840. Since then, Flowserve has pioneered

many innovative advancements in utility pump design. These include:

- Vertical circulating pumps
- High-speed boiler feed pumps
- World's highest horsepower boiler feed pumps
- Double-suction condensate pumps

Flowserve diffuser and volute style pumps have been used in the world's most aggressive services, including supercritical boiler-feed applications, which place exceptional demands on the pumps. Dozens of Flowserve pump installations are rated over 3050 m (10 000 ft) TDH, including many that have set industry benchmarks for availability.

### Diffuser vs. Volute Construction

Double case boiler feed pumps can have one of two internal hydraulic designs: volute or diffuser. Each design is characterized by specific features and benefits. Through class-leading experience and engineering expertise in both hydraulic designs, Flowserve is uniquely positioned to assist customers in selecting the appropriate barrel pump design for their specific applications' needs.

*Diffuser* style pumps are characterized by:

- Tandem (in-line) impellers
- Balancing drum (straight or flanged)
- Radially split, inner case sub-assembly

*Volute*-type pumps have:

- Opposed (back-to-back) impellers
- Balancing sleeve
- Axially split, inner case sub-assembly

**Utility Industry  
Barrel Pumps  
Performance  
Range**

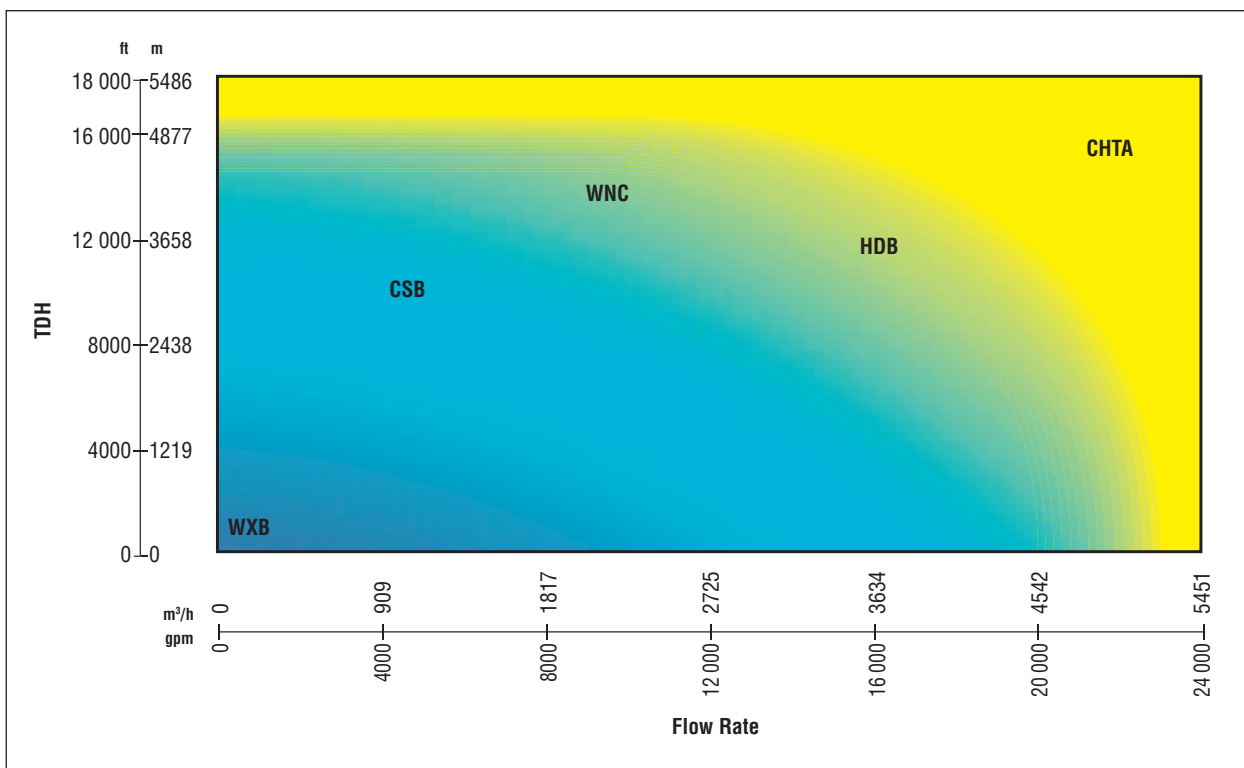
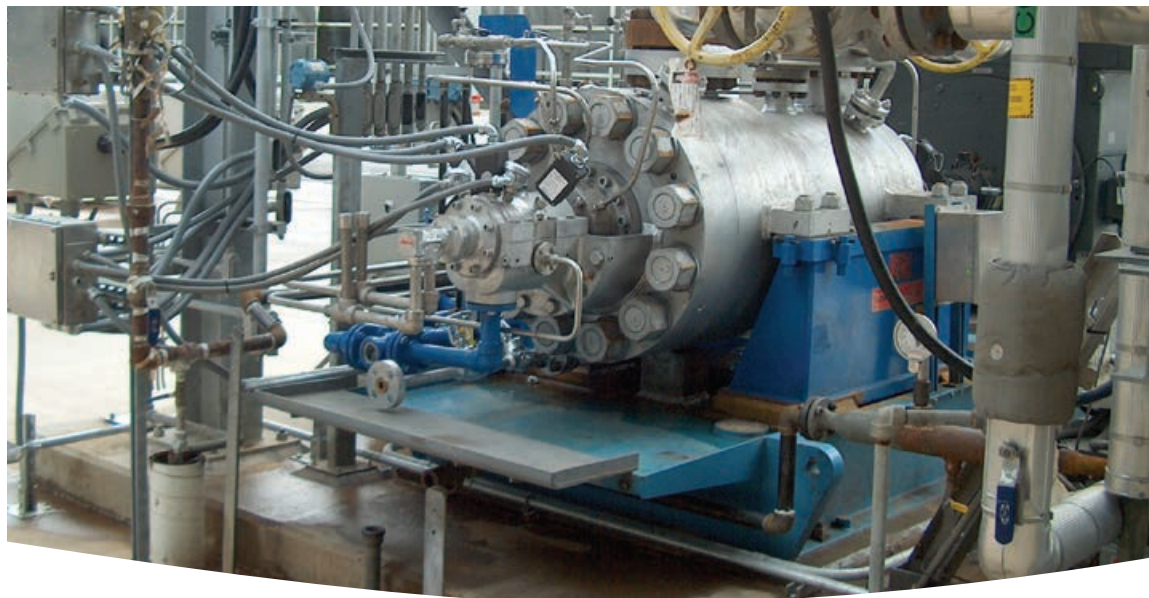

**The Tools of Experience**

For nearly two centuries, Flowserve engineers have pioneered numerous hydraulic design techniques to solve the application challenges faced by end users. With boiler feed pumps operating in power plants throughout the world, Flowserve engineers possess the tools of experience

to design pumps that perfectly fit each individual application's flow and head requirements. While each pump is specifically engineered for a particular service, the above range chart indicates the approximate performance range of the Flowserve utility barrel pumps.



**WXB  
Multistage,  
Diffuser Barrel  
Pump**

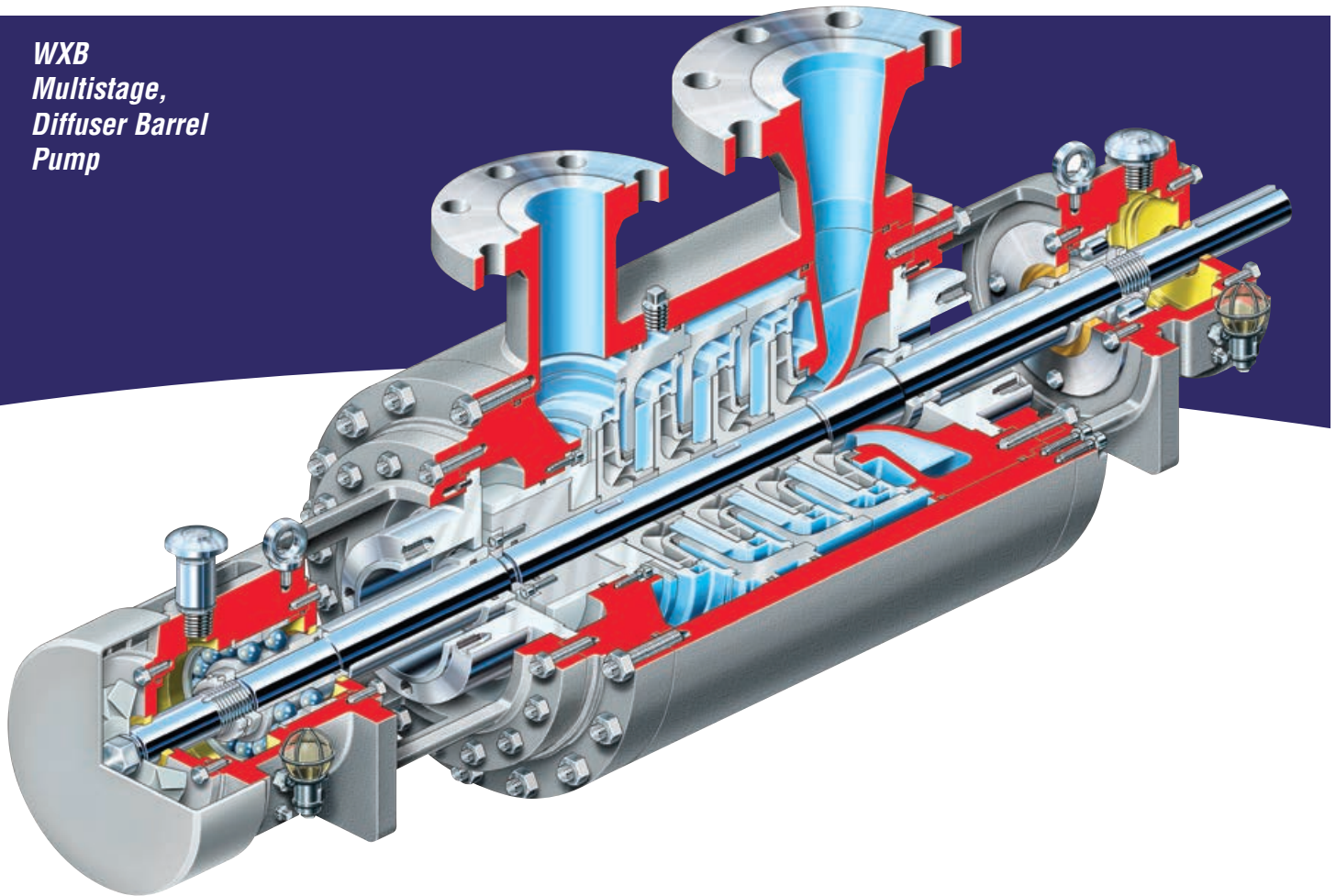

*The WXB is a multistage, diffuser-casing barrel pump with tandem impellers and a balance drum to carry axial thrust forces. It is designed for users who need the hydraulic range and performance of a ring section pump, but demand the design and maintenance attributes of a barrel pump.*

Boasting a compact, space-saving design and convenient cartridge-style construction, the WXB is field proven in power plants, as well as chemical and hydrocarbon plants, throughout the world. It is particularly well suited for smaller combined cycle plants, aero-derivative plants and lower megawatt cogeneration plants.

**Operating Parameters**

- Flows to 300 m<sup>3</sup>/h (1320 US gpm)
- Heads to 1200 m (3940 ft)
- Pressures to 150 bar (2175 psi)
- Temperatures to 200°C (390°F)

**Features and Benefits**

**Radially Split Inner Case Sub-assembly** includes radial and thrust bearings to facilitate inspection and maintenance in the field.

**Generous Shaft Diameter** results in low shaft deflection, thereby increasing bearing, mechanical seal and wear ring life.

**Industry Standard Clearances** between rotating and stationary parts improve pump reliability and decrease sensitivity to contamination.

**ANSI or DIN Flange Connections** are available to meet customer and application requirements. Other flange standards are available upon special request.

**Cartridge-type Mechanical Seals** are standard and minimize downtime.

**Tandem Impeller Design** facilitates maintenance by permitting replacement of a single casing stage.

**Renewable Wear Rings** are standard on all casings and impellers to permit economical restoration of running clearances.

*The WXB is designed for users who need the hydraulic range and performance of a ring section pump, but demand the design and maintenance attributes of a barrel pump.*



### **Precision Cast Impellers**

Impellers are precision cast and dynamically balanced to ensure hydraulic efficiency and performance repeatability. Other notable features include:

- Multiple hydraulic selections allow pumps to be sized to operate in the best efficiency range.
- Large-eye, first-stage impeller optimizes NPSH characteristics.
- Assembled rotor is checked for run-out to minimize vibration.

### **Multivane Diffuser Construction**

With its radially split inner case sub-assembly, the diffuser-casing construction results in balanced radial loads over the entire flow range, including partial-load operation. Ceramic core casting technology produces exceptionally smooth surfaces, enhancing hydraulic efficiency and operation.

### **Antifriction Bearings**

Radial bearings are antifriction deep groove, and thrust bearings are back-to-back angular contact type. Bearings are sleeve mounted to facilitate removal when servicing the bearings or the mechanical seals.

### **Bearing Lubrication**

The bearing lubrication system includes an oil bath, a constant level oiler and an oil sight glass. Furthermore, each bearing housing is equipped with replaceable seal rings and deflectors. This system enables:

- Complete oil penetration without foaming
- Proper oil level in the housing
- Visual oil level verification

### **Axial Thrust Balancing Device**

The WXB pump employs an innovative balancing device that creates nearly constant axial thrust throughout the pump's operating range. This results in minimal balance line flow, leading to improved efficiency at partial load.



### **Back Pull-Out, Cartridge-Style Construction**

The WXB inner case sub-assembly includes the rotor, discharge head, suction head and bearing assembly. This cartridge-style construction allows the entire assembly to be removed as a single unit. This design eases maintenance and reduces downtime by allowing major assembly and disassembly in the workshop rather than in the field.

**WNC  
Multistage  
Diffuser Barrel  
Pump**

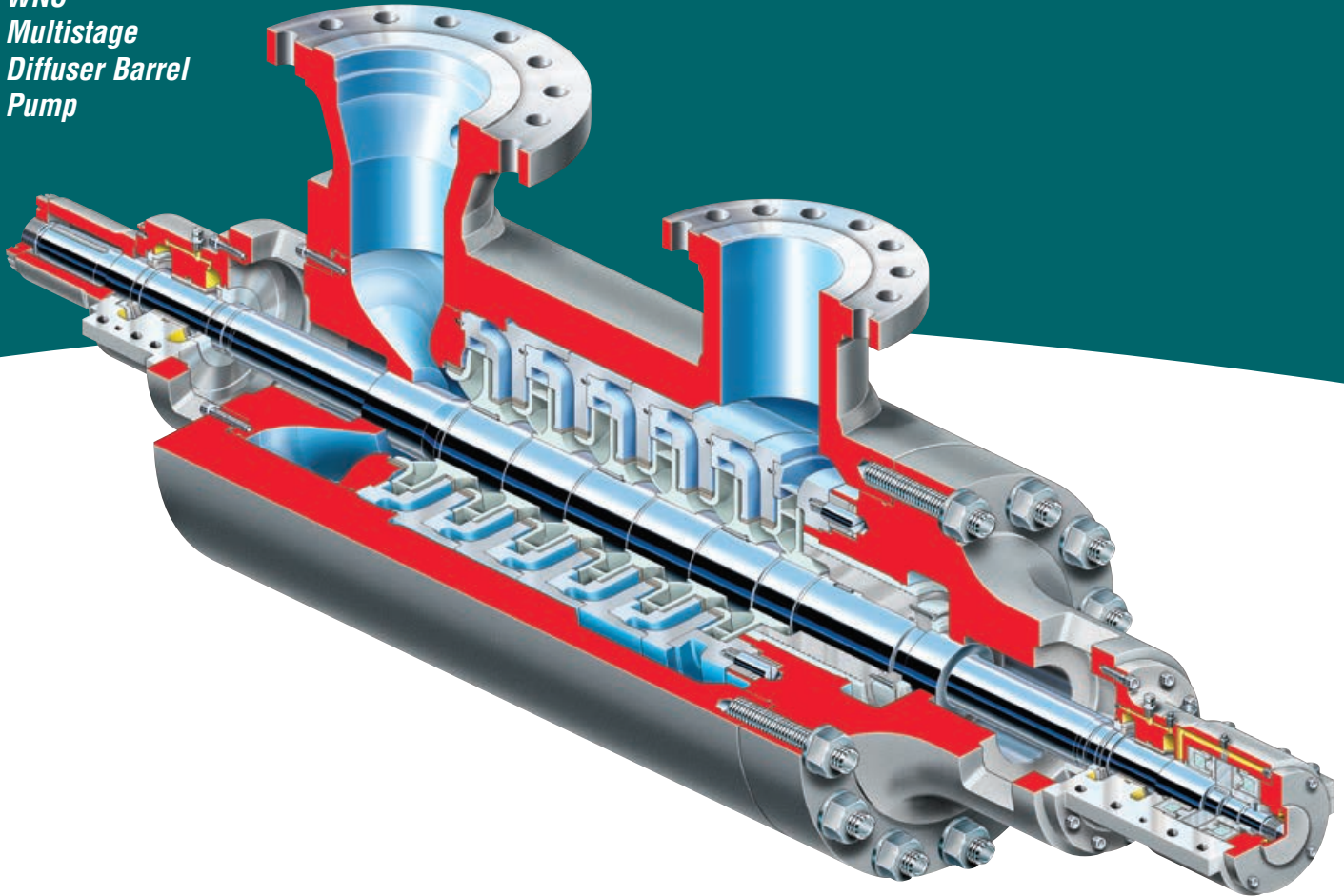

*The WNC is a diffuser-casing, high-energy, barrel pump found in power plants the world over. Highly efficient and durable, the WNC features a massive forged barrel, tandem impellers and a cartridge-style inner casing sub-assembly. Its advanced diffuser design is optimized using the latest computational fluid dynamics technology and the cumulative experience gained from millions of fleet-hours of operation.*

**Operating Parameters**

- Flows to 2350 m<sup>3</sup>/h (10 300 US gpm)
- Heads to 3800 m (12 500 ft)
- Pressures to 350 bar (5075 psi)
- Temperatures to 200°C (390°F)

**Features and Benefits**

**Radially Split Inner Case Sub-assembly** facilitates inspection and maintenance in the field.

**Tandem Impeller Design** facilitates maintenance by permitting replacement of a single casing stage.

**High-strength Rigid Bearing Housings** are incorporated into the WNC design. Several bearing styles are available, including heavy-duty, antifriction radial and thrust bearings, ring oil type radial bearings, and pressure-lubricated radial and tilting pad thrust bearings. Regardless of bearing style, the housing design parameters ensure smooth operation and dependability.

**High Shaft Diameter to Bearing Span Ratio** results in low shaft deflection, thereby increasing bearing, mechanical seal and wear ring life.

**Fully Shrouded Diffusers** are precision cast and 100% NDE inspected to ensure material integrity and dimensional tolerance.

**12% Chromium Steel** hydraulic components for increased performance. They include the discharge head and barrel, stage pieces and the impellers as a standard.



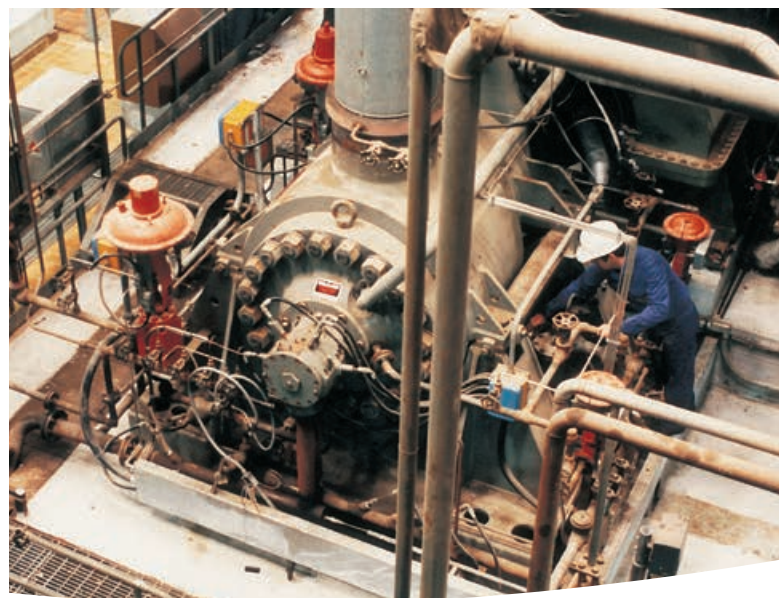
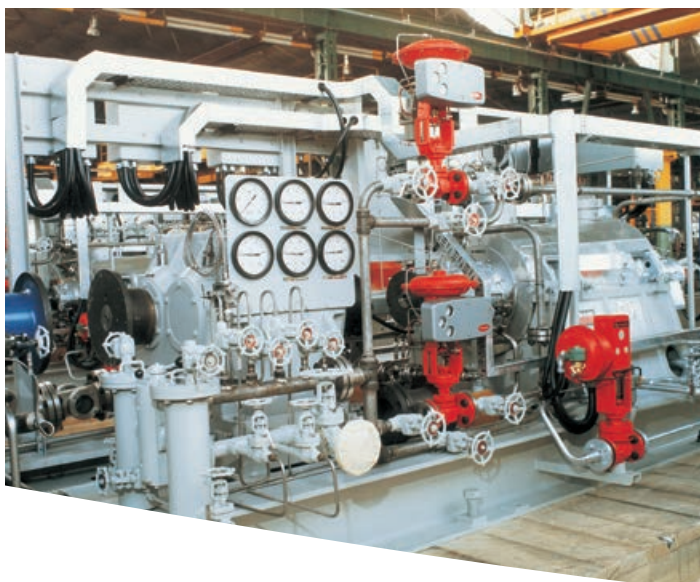

### **Cartridge-Style Configuration**

The cartridge-style construction of the WNC permits the complete inner case sub-assembly to be removed from the barrel without disconnecting the suction and discharge flanges. This design facilitates maintenance by allowing users to remove the cartridge with minimal downtime.

This design allows all the rotor components to be removed as a complete unit without prior disassembly.

- Channel rings (inner casings)
- Diffusers
- Impellers
- Shaft
- Radial and thrust bearings
- Seals

### **Diffuser-Style Construction**

With its radially split, inner case sub-assembly, the diffuser-casing construction of the WNC results in balanced radial loads. For precise hydraulic operation, the diffuser design can be optimized within a given set of operational parameters. This will further increase efficiency and lower power consumption, while simultaneously contributing to a smoother running pump. Moreover, its tandem impeller design facilitates maintenance by permitting replacement of a single casing stage. Likewise, the pump can be de-staged easily if the differential head requirement is reduced.

### **Multiple Axial Thrust-Balancing Designs**

To suit site-specific requirements or user preferences, the WNC is available with a variety of axial thrust-balancing designs. Proven in the hydrocarbon and power generation industries, these thrust-balancing systems offer the application flexibility and reliability demanded by hydrocarbon charge, water injection and boiler feed services.

### **Available Shear Ring Closure**

As an option on lower pressure applications, a unique shear ring closure system replaces the traditional bolting on the discharge cover. In this configuration, the high-strength split seal ring is locked into the barrel body by cap nuts. This design maintains cartridge integrity, but allows maintenance with conventional tooling. The shear ring design is more compact and boasts one of the quickest maintenance turnarounds in the industry.

### **Shear Ring Operating Parameters**

- Flows to 1400 m<sup>3</sup>/h (6200 gpm)
- Heads to 2135 m (7000 ft)
- Pressures to 250 bar (3600 psi)
- Synchronous speeds 3000–3600 rpm
- Temperatures to 200°C (390°F)

*WNC Shear Ring*

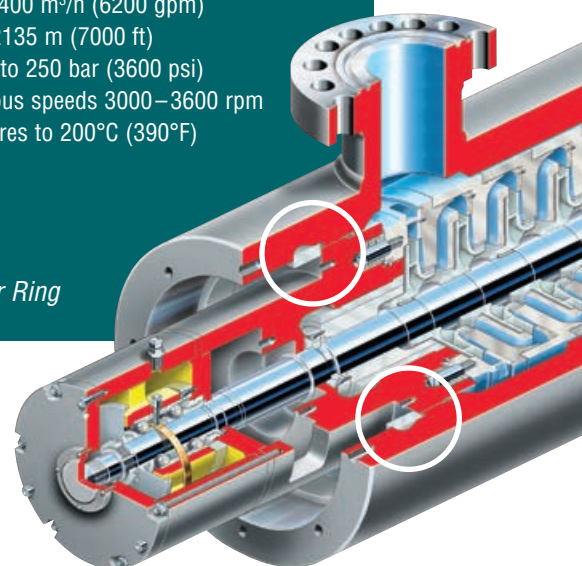

**CSB  
Multistage  
Diffuser Barrel  
Pump**

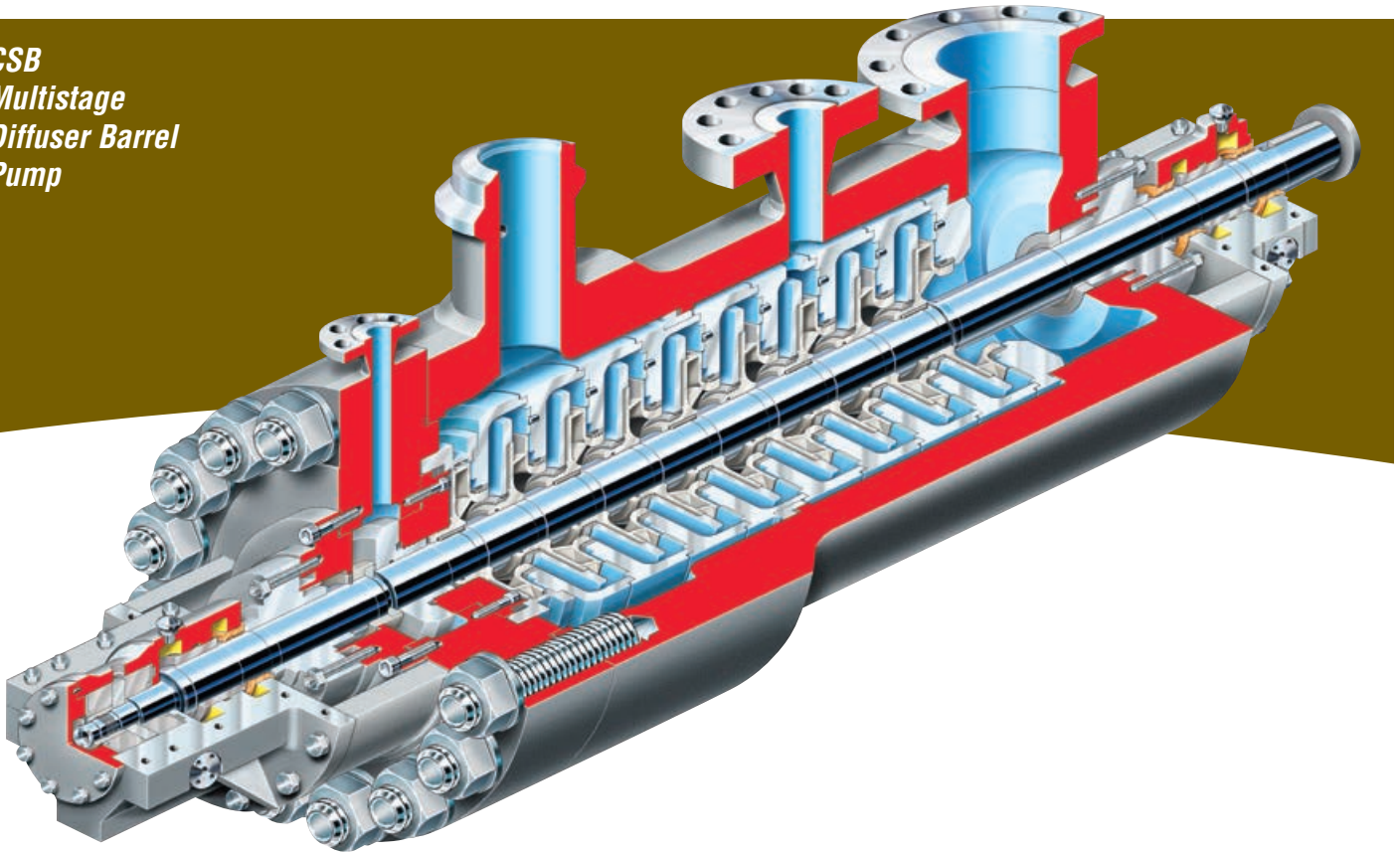

*The CSB diffuser barrel pump has become the industry benchmark in boiler feed service. It delivers exceptionally smooth pumping in a compact, space-saving design. An excellent choice for both combined cycle and conventional steam cycle plants, the diffuser design of the CSB provides operational stability, hydraulic flexibility, and energy efficiency in medium- and heavy-duty applications.*

From the unique continuous cross-over diffuser to the homogenous barrel forging, the CSB incorporates and improves upon many of the time-proven technologies that Flowserve has pioneered. The design has been optimized by several computer-aided design techniques, creating a pump that is cost-effective while still offering the robust performance demanded of a utility-grade barrel pump.

**Operating Parameters**

- Flows to 1500 m<sup>3</sup>/h (6600 gpm)
- Heads to 3650 m (12 000 ft)
- Pressures to 300 bar (4350 psi)
- Temperatures to 250°C (480°F)
- Speeds to 6000 rpm

**Features and Benefits**

**Radially Split, Inner Case Sub-assembly** includes radial and thrust bearings to facilitate inspection and maintenance in the field.

**High Shaft Diameter to Bearing Span Ratio** results in low shaft deflection, thereby increasing bearing, mechanical seal and wear ring life.

**Tandem Impeller Design** facilitates maintenance by permitting replacement of a single casing stage.

**Continuous Cross-over Diffuser** precisely converts velocity energy to pressure energy throughout the entire streamline from impeller discharge. This technology permits a more rigid and compact pump design and offers exceptionally efficient performance.

**Standard 1.25% Chromium High-strength Barrel** is cost-effective, corrosion resistant and durable.

**Flanged Balance Drum** ensures impeller thrust is balanced at all operating conditions.

**Tri-land Radial Bearing** creates a higher centering force than conventional journal bearings to increase dynamic rotor stiffness and vibration dampening.



*The CSB provides operational stability, hydraulic variability and energy efficiency in medium-duty applications.*

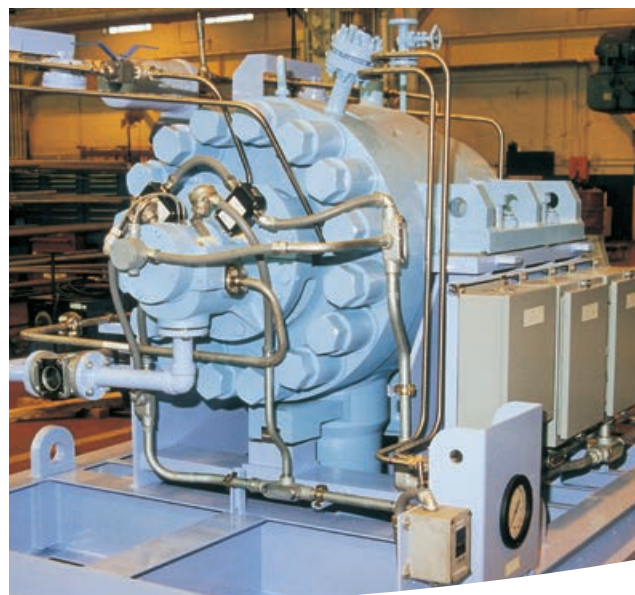

### **Barrel Forging**

The barrel on the CSB is forged out of homogeneous, high-strength 1.25% chromium steel. This material possesses exceptional metallurgical qualities, including excellent resistance to erosion-corrosion. The barrel is optimally designed to ensure flawless performance at normal or transient pressures and temperatures. Furthermore, its excellent machining and welding characteristics allow for precise interstage takeoff and superheater spray connections.

### **Rotor Design**

The rotor of the boiler feed pump is the heart of the entire steam cycle system, not just the pump itself. Due to its critical nature, Flowserve engineers employ advanced dynamic analysis and manufacturing techniques to ensure the CSB rotor is the most solid and dependable in the industry.

### **Multivane Diffuser Construction**

With its radially split, inner case sub-assembly, the diffuser-casing construction results in balanced radial loads over the entire flow range, including partial-load operation. Ceramic core casting technology produces exceptionally smooth surfaces, enhancing hydraulic efficiency and operation.

### **Continuous Cross-Over Diffuser**

The unique continuous cross-over diffuser of the CSB precisely converts velocity energy to pressure energy throughout the entire streamline from impeller discharge. This technology permits a more rigid and compact pump design and offers exceptionally efficient performance.

### **Mixed Hydraulic Capabilities**

A common requirement of advanced plant designs, especially combined cycle, is varying flows throughout the pump. Frequently, suction flow into the pump is split into partial discharge, such as intermediate pressure bleed and full discharge. Flowserve is experienced in designing pumps with several internal capacities. Furthermore, Flowserve has the design ability to match pump flows with system requirements to simplify systems and reduce initial plant construction expense.

### **Special Flow Offerings**

With the requirements of interstage bleed-offs, superheater, and attemperator flows, a pump is often required to produce flow at a variety of pressures. Flowserve has built barrel pumps with intermediate flow pressures from first-stage, low-pressure bleeds to superheater spray kicker stages that advance the pressure over full discharge.

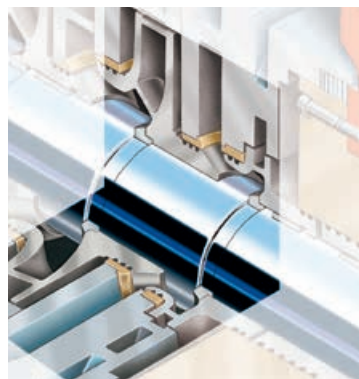

**Available Kicker Stage**



**CHTA**  
**Heavy-Duty**  
**Multistage**  
**Diffuser Barrel**  
**Pump**

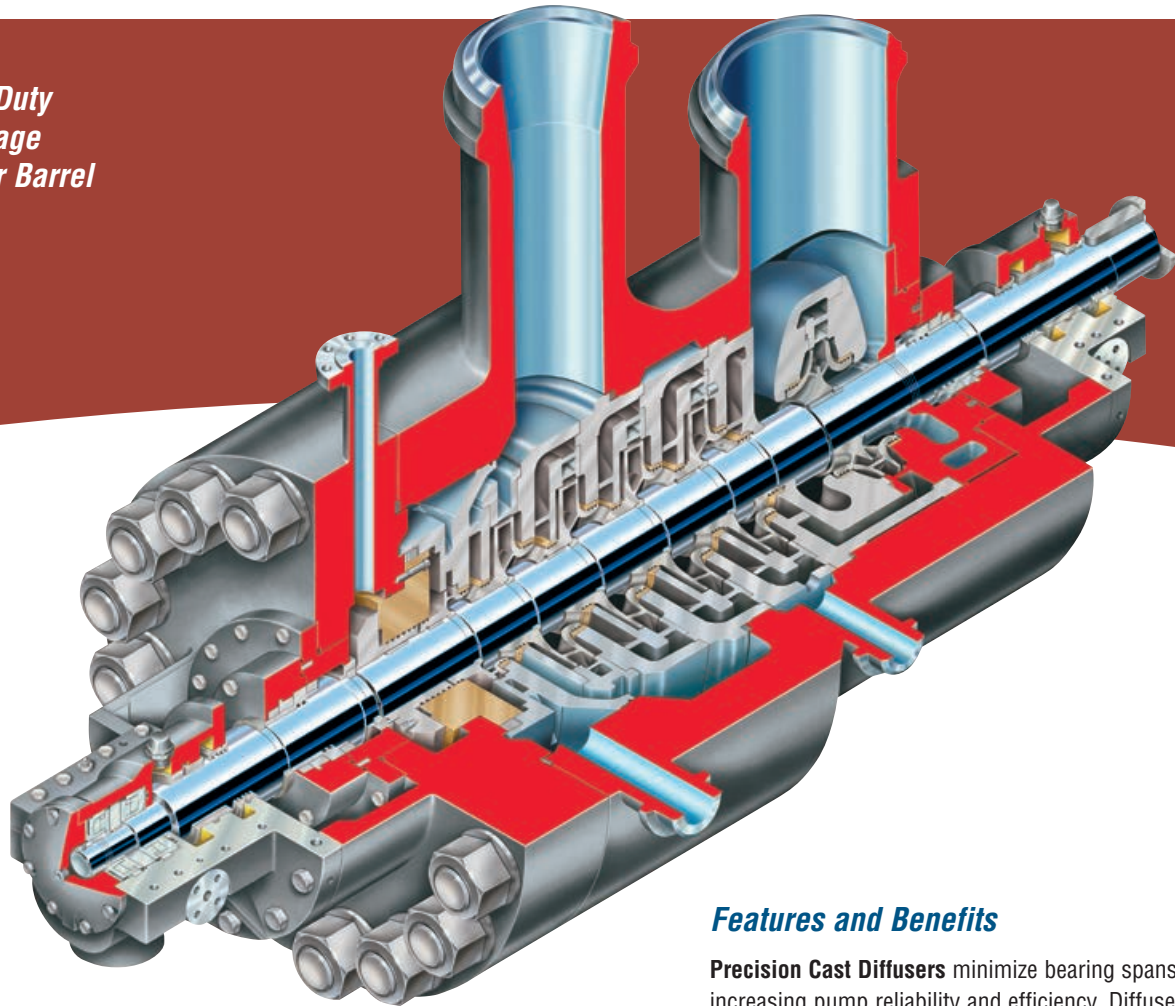

*As the world's most powerful boiler feed pump (52 000 kW [70 000 hp]), the CHTA diffuser barrel pump is a true behemoth, capable of handling the most demanding and high-energy applications. It is often unspared in supercritical coal-fired power plants and for extended service runs. Having accumulated millions of hours of successful operation, the CHTA is the standard by which reliability is judged.*

**Operating Parameters**

- Flows to 5220 m<sup>3</sup>/h (23 000 gpm)
- Heads to 4270 m (14 000 ft)
- Pressures to 517 bar (7500 psi)
- Temperatures to 250°C (480°F)
- Speeds to 6000 rpm

**Features and Benefits**

**Precision Cast Diffusers** minimize bearing spans, increasing pump reliability and efficiency. Diffusers are fully shrouded on high-energy applications. Each diffuser is 100% NDE inspected, and all critical dimensions are recorded to ensure component integrity.

**Suction and Discharge Connections** can be located on the top or the bottom of the barrel and may be supplied with flanged or weld end design.

**Self-aligning, Double-acting Tilt-pad Thrust Bearings** are conservatively rated to carry axial loads that may be encountered during transient operating conditions.

**Precision Cast Tandem Impellers** are positively locked and keyed to the shaft. Running fits are serrated to reduce the effect of rotor contact should it occur during system upset or turning gear operation.

**Casing Rings** facilitate maintenance and enable running clearances to be renewed easily. For maximum reliability at the running fits, no impeller rings are used.

**Belleville Springs** in the thrust bearing housing reduce sensitivity to turning gear operation by opening the balancing drum and sleeve face. This allows free passage of liquid which may contain suspended solids.

*As the world's largest boiler feed pump (52 000 kW [70 000 hp]), the CHTA diffuser barrel pump is a true behemoth, capable of handling critical, high-energy applications.*

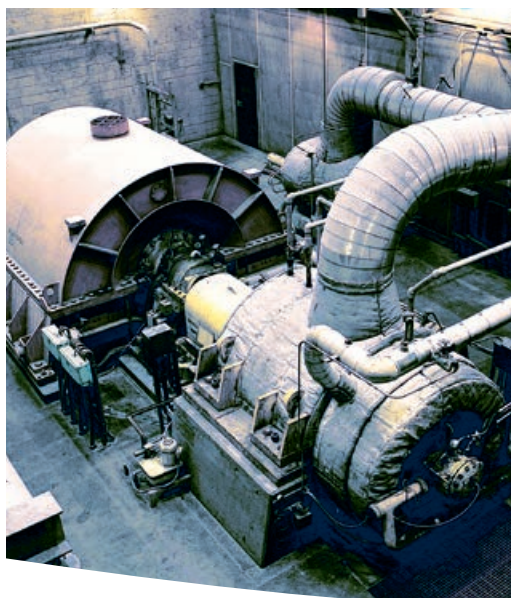

### ***Rugged Rotor Design***

As a function of the rotor design, the CHTA ensures smooth operation. By knowing the demands placed on the pump in supercritical service, Flowserve has been able to refine the design to one that is fail-safe. Each running fit on the rotor is checked to ensure proper clearance and concentricity. A compensation gasket group permits differential expansion of rotor and barrel during temperature transients.

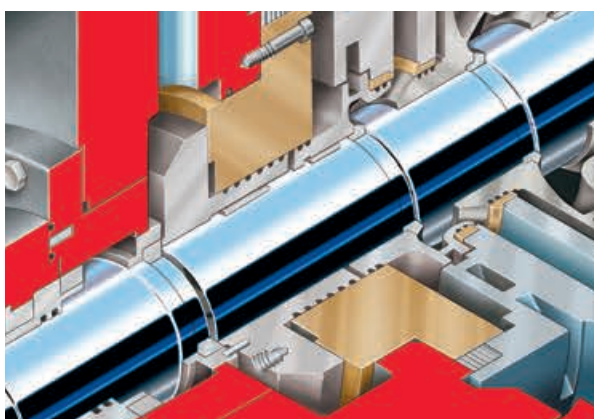

### ***Forged and Hardened Stainless Steel Balance Drum and Sleeve***

The CHTA's flanged drum is conservatively sized to completely unload the thrust bearing at all operating points. Typically, pressure throttling is accomplished in the radial direction to reduce leakage and wear on axial clearances. Clearance is easily renewed with an adjustment in the thrust bearing. Pioneered by Flowserve and field proven by the entire utility industry, this design is the most efficient way to balance axial thrust. It reduces auxiliary loads and improves overall plant output.

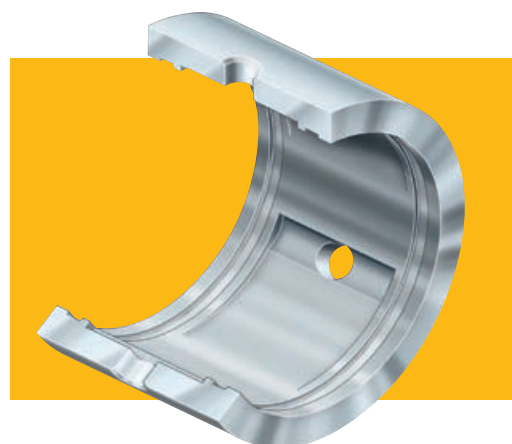

### ***Smooth-Running Journal Bearings***

The CHTA employs three element-tapered, land sleeve type (tri-land) radial journal bearings. The enhanced hydrodynamic effect of tri-land bearings results in smooth pump operation, which prolongs pump life and facilitates shaft sealing. Three equally spaced 30-degree, arc-tapered lands blend into 30-degree, arc-concentric journals. Oil is introduced at each of the three tapered lands. The bearings are split for easy maintenance.

### ***12% Chromium Steel Construction***

The CHTA features 12% chromium steel components for improved performance. They include:

- Stage pieces
- Impellers
- Shaft



**HDB**  
**Multistage,**  
**Dual Volute,**  
**Utility Barrel**  
**Pump**

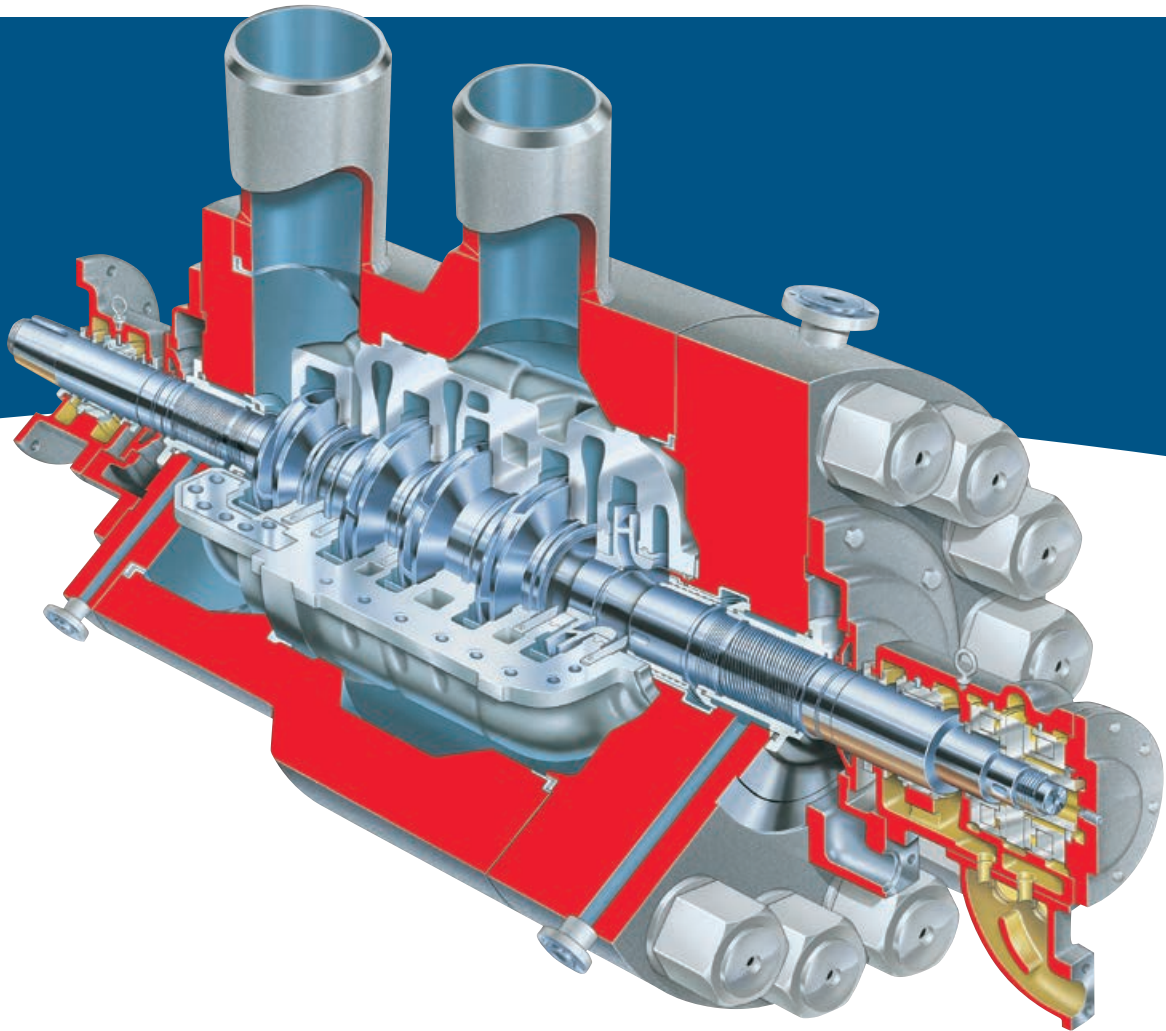

*The HDB is a multistage, dual volute-type barrel pump with an axially split inner case sub-assembly. It features opposed impeller construction and incorporates a double-suction, first-stage impeller.*

The HDB is well known in the power industry for its extended run times, a benefit of its highly engineered design. Inherent to the volute barrel design are features that contribute to the operational stability and reliability of the pump. These features include:

- Massive forged barrel
- Utility grade rotor design
- Heavy-duty bearings
- Rugged volute design

**Operating Parameters**

- Flows to 4000 m<sup>3</sup>/h (17 610 US gpm)
- Heads to 4300 m (14 000 ft)
- Pressures to 450 bar (6525 psi)
- Temperatures to 425°C (800°F)
- Speeds to 9000 rpm

**Features and Benefits**

**Inner Case Sub-assembly**, consisting of identical halves, features dual volutes with outlets 180° apart. This design assures radial balance throughout the entire operating range.

**Pump Design** features only one high-pressure, fully confined circular compression gasketed sealing joint to the atmosphere.

**Nozzles** are either flanged or weld-end type. Orientation can be either vertical up or down to suit site requirements.

**Pivot Shoe Type Tilting Pad Thrust Bearing** and sleeve type journal bearings are standard.

**A Double-suction, First-stage Impeller** is available to meet NPSH requirements and offers stability over a wide range of flows. A single suction, first-stage impeller option is available for high NPSHA conditions, reducing barrel length and bearing span.



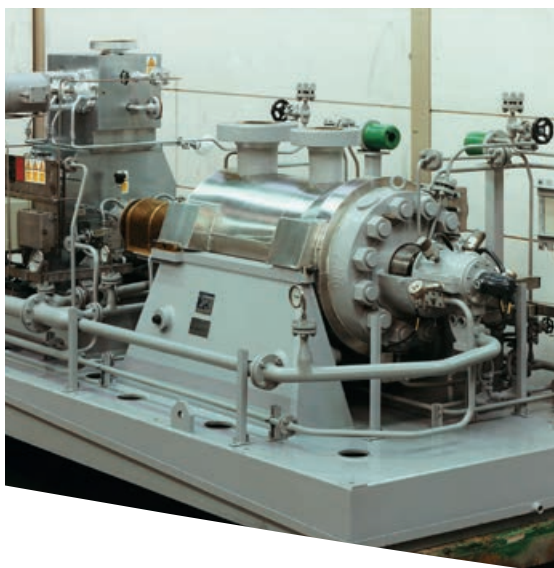

### ***Double Volute Design***

The double volute design of the HDB permits the equivalent natural deflection of the rotating element to be machined into the bottom volute case. This optional design element, called sag bore, allows running clearances to remain concentric during standby or turning gear operation.

### ***Axially Balanced Opposed Impellers***

The opposed impeller design of the HDB results in inherently balanced axial hydraulic thrust over the full operating range of the pumps. Impellers are precision cast to improve hydraulic efficiency and performance repeatability. The impellers are secured to the shaft with a shrink fit and keyed with split rings.

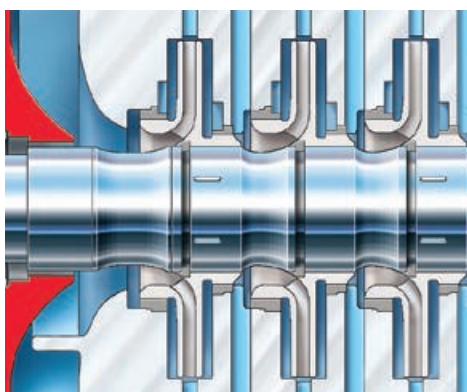

### ***Scarfed Shaft***

Twelve percent chromium steel-forged shaft is scarfed at each impeller suction eye to afford maximum streamlining and minimum peripheral eye velocity of the pumped liquid. Forged shafts are incrementally stepped at every other impeller fit for ease of assembly. The standard shaft extension is a NEMA taper.

### ***Fully Precision-Machined Inner Case***

The identical halves of the axially split inner case are fully precision machined and under hydraulic compression. This design eliminates gasketing. As such, only light bolting is required, facilitating maintenance.



### ***Dynamically Balanced Rotating Element***

The fully assembled rotating element is dynamically balanced and then installed into the inner case as a complete unit, ensuring excellent rotordynamic stability.

*Options and  
Technical  
Information*

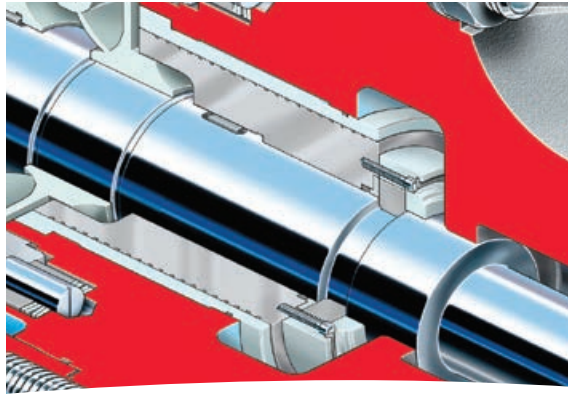

*Straight balance drum*

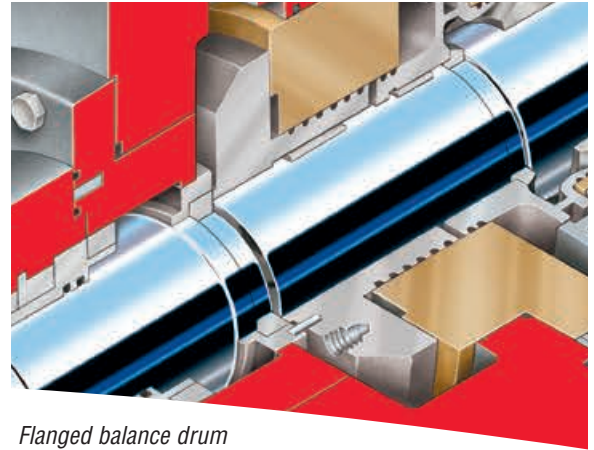

*Flanged balance drum*

**Optional Balance Drum Designs**

The balance drum carries the axial hydraulic thrust produced by the tandem impeller arrangement of diffuser pumps. Flowserve offers both flanged or straight drum designs to suit application requirements. Furthermore, special materials are available to reduce erosion and component life.

**Driver Options**

Flowserve offers numerous driver options to suit customer preferences and site requirements. Drive options include:

- Direct electric motor
- Electric motor with a step-up gear
- Variable frequency drive
- Electric motor with geared hydraulic coupling
- Geared or non-geared steam turbine
- Geared or non-geared gas turbine
- Power recovery turbine assisted

**Grooved Running Fits**

Running fits may be grooved to provide the following safeguards:

- Desensitize pump during starting, stopping and system transients
- Increase pump's tolerance for foreign materials

**Pumping Systems**

Factors affecting the arrangement of pumping systems include process requirements, equipment availability, experience and economics, among other things. Typical arrangements are:

- Three 33% capacity pumps
- Two or three 50% or 60% capacity pumps
- One 100% capacity pump

**Baseplate Designs**

Baseplates are made of reinforced steel in one of three standard designs, depending on equipment size and drive trains. All come with a drain rim.

- Common baseplate for both pump and driver
- Sub-base under pump only
- Multiple-element baseplate

Concrete pedestal designs are also available.





*Flowserve offers two advanced laser treatments to create superior surface properties on critical clearance parts.*

*Laser-hardened, flanged balancing drum*

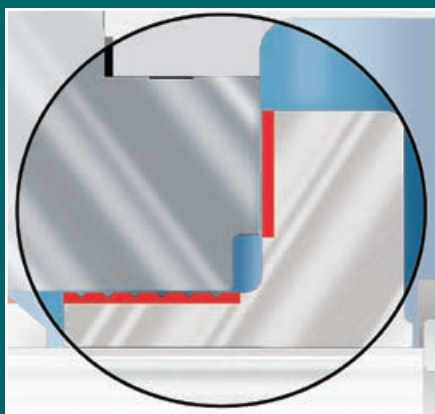

*DLD-treated impeller with front and back integral wear rings*

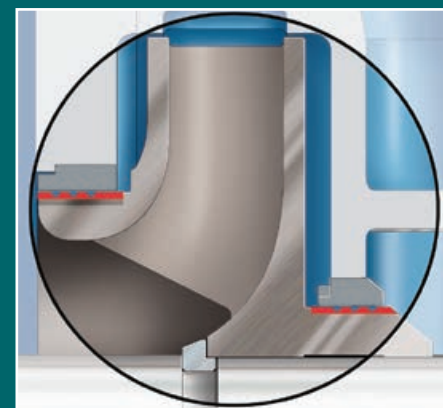

### ***Laser-Processing Technologies***

Flowserve offers two advanced laser treatments to create superior surface properties on critical clearance parts. These processes are an effective means of improving component reliability and durability. These treatments include:

- Laser hardening
- Direct laser deposition (DLD)

These treatments are often applied to impeller hubs, impeller wear rings and casing wear rings. The surfacing improves durability and allows more precise optimization of the corresponding clearances. The hydraulic balance surfaces are also frequently treated for improved pump life and efficiency.

### ***Single- or Double-Suction, First-Stage Impellers***

Most Flowserve barrel pumps are available with either single- or double-suction, first-stage impellers. Flowserve hydraulic engineers are able to precisely fit a pump to the system requirements with either impeller design. Furthermore, Flowserve engineers have optimized various diameter suction eyes that also can be implemented. The “leading edge hook” and “bias-wedge” Flowserve designs virtually eliminate cavitation damage, contributing to a smoother running pump while prolonging pump life.

#### ***Double-Suction, First-Stage Impeller***

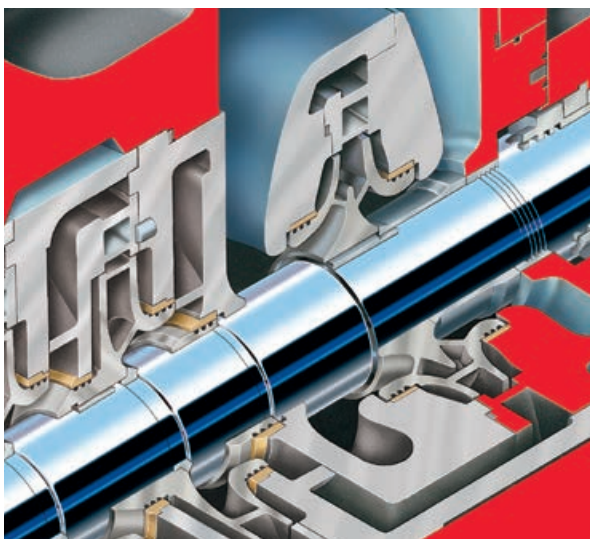

#### ***Single-Suction, First-Stage Impeller***

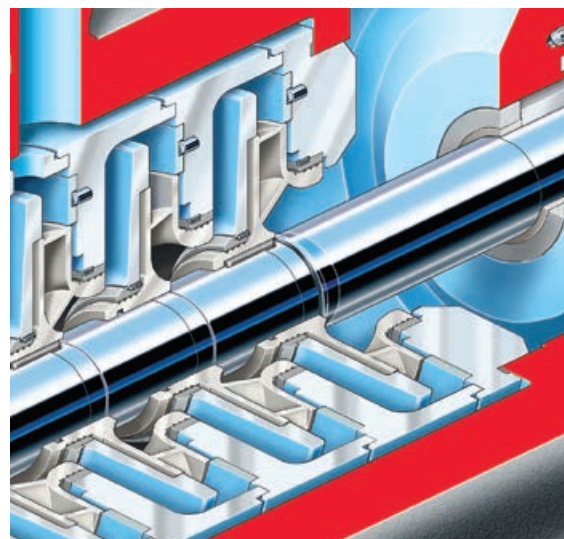



## Mechanical Seal Solutions

Tandem QBQ

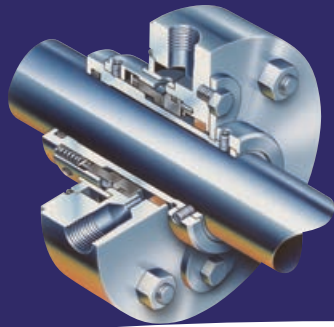

DHTW

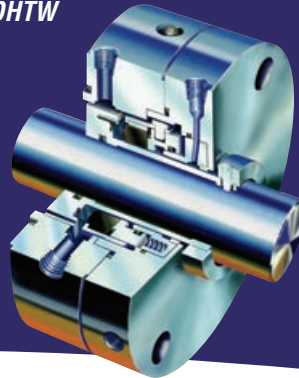

DHTW in plan 23 system

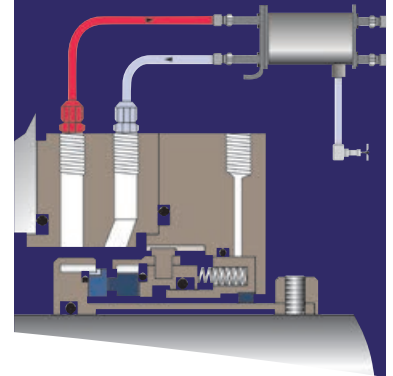

With manufacturing advances and technology improvements, mechanical seals are now the standard for sealing barrel pumps. Longer life and lower total cost are factors that have contributed to this change. Flowserve has advanced mechanical seals to fit any new boiler feed pumps and the capability to retrofit them into existing units.

### QB Boiler Feed Pump Seal

The QB is the preferred seal for modern combined cycle and steam cycle boiler feed service. When used in conjunction with a plan 23 system, the QB provides long life, even in a cycling environment.

### Tandem QBQ for Safety and Near-Zero Emissions

Tandem seal technology provides for safety backup in hazardous services and provides emissions control in critical environmental applications.

### Operating Parameters

- Suction pressures to (52 bar) 750 psi
- Stuffing box temperatures:
  - Water solutions from 0°C to 135°C (32°F to 275°F)
  - Other liquids from -40°C to 200°C (-40°F to 400°F)

### Features and Benefits

- Near-zero emissions contained primary seal leakage for proper disposal. Lab and field tested to less than 50 ppm. Meets SCAQMD Rule 1173
- Full pressure-rated backup seal allows pump operation to a safe and orderly shut-down.
- Multiport injection available to optimize face cooling, reducing face distortion
- Cartridge design provides easy installation and reduced downtime.

### Custom-Engineered DHTW

Specifically engineered for the power industry, the DHTW provides reliable high-speed, high-pressure operation and is capable of withstanding “hot standby” conditions. Although it is commonly found in supercritical steam plants as a field-installed upgrade to a condensate injection system, the DHTW is also available in new equipment.

### Operating Parameters

- Pressures to (172 bar) 2500 psi
- Temperatures to 200°C (400°F)

### Features and Benefits

- Seal components remain flat under all conditions.
- Precise seal balance reduces friction and energy needs.
- Cartridge design simplifies installation and reduces downtime.
- Integral pumping ring for use with plan 23 eliminates the need for cold condensate injection or make-up water — even in hot stand-by conditions.

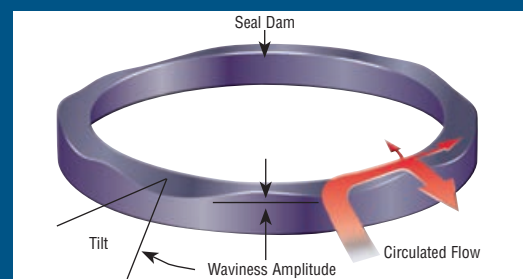

### Innovative Wavy Face Technology

Non-contacting design allows seal faces to run cooler with less wear and with low running torque losses to the motor. Low heat loads allow other system components to have a wider band range, increasing their tolerance for normal operation transients. Self-cleaning Wavy Face technology enables the seal faces to endure boiler system additives, conditioners and water scale residue.

**Global Service  
and Technical  
Support**



## Life Cycle Cost Solutions

Typically, 90% of the total life cycle cost (LCC) of a pumping system is accumulated after the equipment is purchased and installed. Flowserve has developed a comprehensive suite of solutions aimed at providing customers with unprecedented value and cost savings throughout the life span of the pumping system. These solutions account for every facet of life cycle cost, including:

### Capital Expenses

- Initial purchase
- Installation

### Operating Expenses

- Energy consumption
- Maintenance
- Production losses
- Environmental
- Inventory
- Operating
- Removal

### Innovative Life Cycle Cost Solutions

- New Pump Selection
- Turnkey Engineering and Field Service
- Energy Management
- Pump Availability
- Proactive Maintenance
- Inventory Management

### Typical Pump Life Cycle Costs<sup>1</sup>

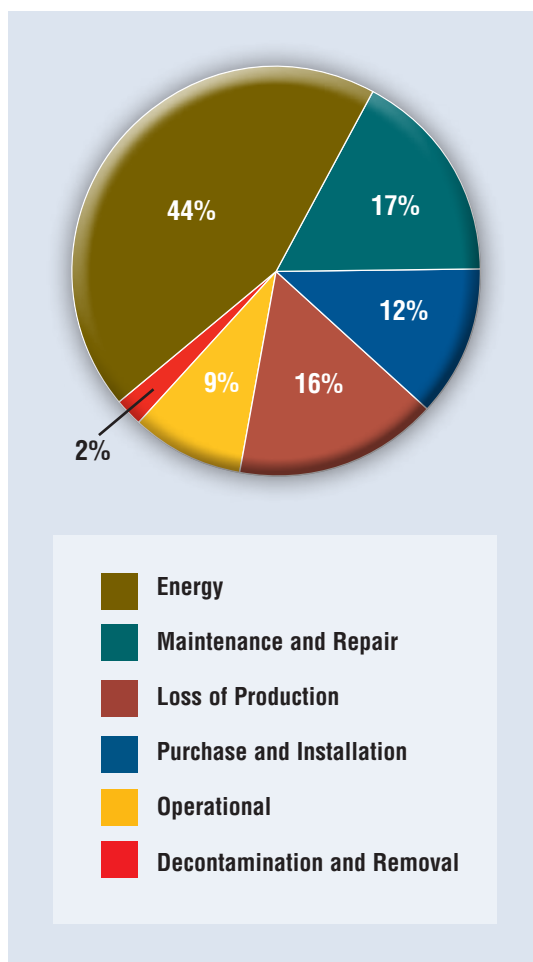

<sup>1</sup> While exact values may differ, these percentages are consistent with those published by leading pump manufacturers and end users, as well as industry associations and government agencies worldwide.





Bulletin PS-30-12f (E/A4) September 2015. © 2015 Flowserve Corporation

***To find your local Flowserve representative:***

For more information about Flowserve Corporation,  
visit [www.flowserve.com](http://www.flowserve.com) or call +1 937 890 5839.

**USA and Canada**

Flowserve Corporation  
5215 North O'Connor Blvd.  
Suite 2300  
Irving, Texas 75039-5421 USA  
Telephone: +1 937 890 5839

**Europe, Middle East, Africa**

Flowserve Corporation  
Parallelweg 13  
4878 AH Etten-Leur  
The Netherlands  
Telephone: +31 76 502 8100

**Latin America**

Flowserve Corporation  
Martín Rodríguez 4460  
B1644CGN-Victoria-San Fernando  
Buenos Aires, Argentina  
Telephone: +54 11 4006 8700  
Telefax: +54 11 4714 1610

**Asia Pacific**

Flowserve Pte. Ltd.  
10 Tuas Loop  
Singapore 637345  
Telephone: +65 6771 0600  
Telefax: +65 6862 2329